

T-10D PANEL

WALL PANEL

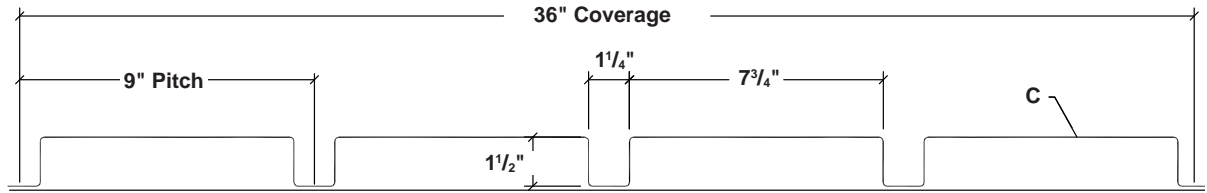

ARCHITECTURAL
COMMERCIAL
INDUSTRIAL
PANEL

DIRECT FASTENED
(EXPOSED)

36"
COVERAGE

CUSTOM
CAPABILITIES

OPEN FRAMING OR
SOLID SUBSTRATE

PANEL OVERVIEW

- ▶ Finishes: Kynar 500 (PVDF) standard, optional; multi-pass Kynar, Marblique, Plastisol, Polyester, and MS Colorfast45® (SMP)
- ▶ Gauges: 24ga standard, 22ga, 20ga, and 18ga
- ▶ 36" panel coverage, 1½" rib height
- ▶ Crisp 90° vertical box ribs on 9" centers
- ▶ Optional material availability: Stainless Steel, Weathering Steel, Copper, and Aluminum
- ▶ Exposed fastened panel
- ▶ Custom capabilities include:
 - Crimp curving
 - Curving may be convex, concave, or "S" curves
 - Perforated panels for wind screens and liner panels

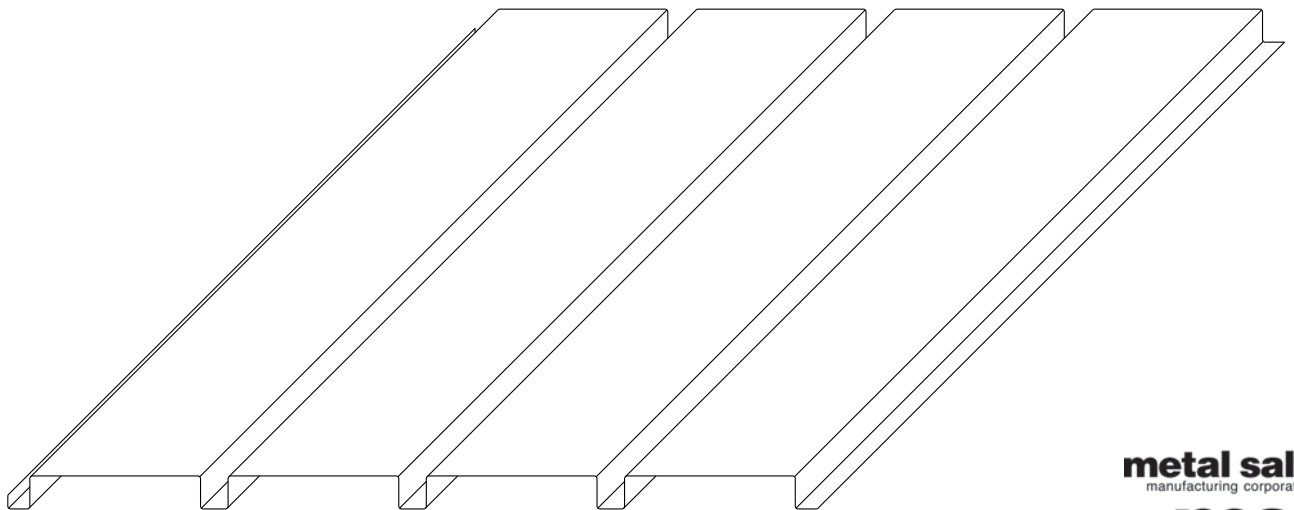

T-10D PANEL

ATTACHMENT DETAIL

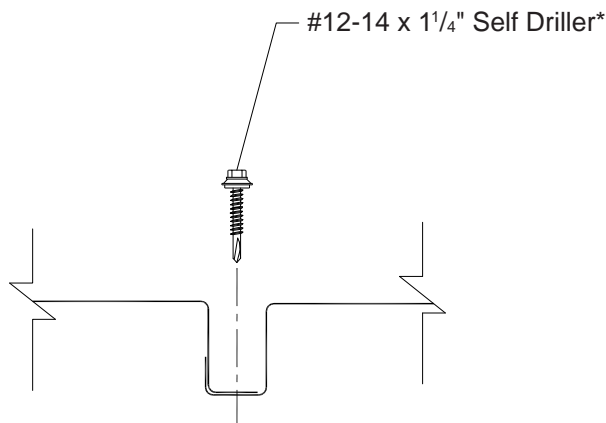

FASTENING PATTERNS

Fastening Pattern (Ends)



Fastening Pattern (Field)

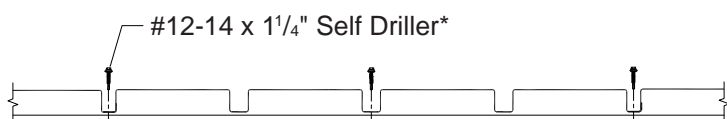

*Note: #12-14 x 1" Self Driller is used for non-insulated applications.

GENERAL INFORMATION

► Substructure

T-10D Panel is designed to be utilized over open structural framing, or a solid substrate.

► Coverage

T-10D Panels are available in a 1 1/2" depth with a 36" width coverage.

► Length

Minimum factory cut length is 5'-0".
Maximum recommended panel length is 36'-0".

► Fasteners

The fastener selection guide should be consulted for choosing the proper fastener for specific applications. Quantity and type of fastener must meet necessary loading and code requirements.

NOTE: All panels are subject to surface distortion due to improperly applied fasteners. Overdriven fasteners will cause stress and induce oil canning across the face of the panel at or near the point of attachment.

► Availability

Finishes: Kynar 500 (PVDF) standard; optional: multi-pass Kynar, Marblique, Plastisol, Polyester, and MS Colorfast45® (SMP)
Gauges: 24ga, 22ga, 20ga, and 18ga

SECTION PROPERTIES

ALLOWABLE UNIFORM LIVE LOADS PSF (3 or More Equal Spans)

Ga.	Width (in.)	Yield KSI	Weight PSF	Top in Compression		Bottom in Compression		Inward (Gravity / Deflection) Load						Outward Uplift (Stress) Load					
				Ixx In ⁴ /ft	Sxx In ³ /ft	Ixx In ⁴ /ft	Sxx In ³ /ft	4'	5'	6'	7'	8'	10'	4'	5'	6'	7'	8'	10'
24	36"	50	1.31	0.1013	0.0861	0.0597	0.0754	108	69	48	36	27	18	163	105	74	54	42	27
22	36"	50	1.69	0.1410	0.1214	0.8530	0.1102	157	101	71	52	40	23	229	148	103	76	58	38
20	36"	33	2.01	0.1767	0.1515	0.1200	0.1396	131	84	59	43	33	21	188	122	85	63	48	31
18	36"	33	2.63	0.2333	0.2020	0.1800	0.1903	178	115	80	59	45	29	251	162	113	84	64	41

- Theoretical section properties have been calculated per AISI 2001 "Specification for the Design of Cold-formed Steel Structural Members." Ixx and Sxx are effective section properties for deflection and bending.
- Allowable load is calculated in accordance with AISI 2001 specifications considering bending, shear, combined bending and shear, deflection. Allowable load considers the worst case of 3 and 4 equal span conditions. Allowable load does not address web crippling, fasteners/support connection, or panel disengagement. Panel weight is not considered.
- Deflection consideration is limited by a maximum deflection ratio of L/180 of span.
- Allowable loads do not include a 1/3 stress increase.



Kent, WA (800) 431-3470
Temple, TX (800) 543-4415
Longmont, CO (800) 289-7663
Antioch, TN (800) 251-8508
Woodland, CA (800) 759-6019
Rogers, MN (800) 328-9316
Spokane, WA (800) 572-6565

Jefferson, OH (800) 321-5833
Rock Island, IL (800) 747-1206
Sellersburg, IN (800) 999-7777
Jacksonville, FL (800) 394-4419
Orwigsburg, PA (800) 544-2577
Independence, MO (800) 747-0012
Fontana, CA (800) 782-7953

Anchorage, AK (866) 640-7663
Bay City, MI (888) 777-7640
Detroit Lakes, MN (888) 594-1394
Mocksville, NC (800) 228-6119