

T7 PANEL

ROOF PANEL

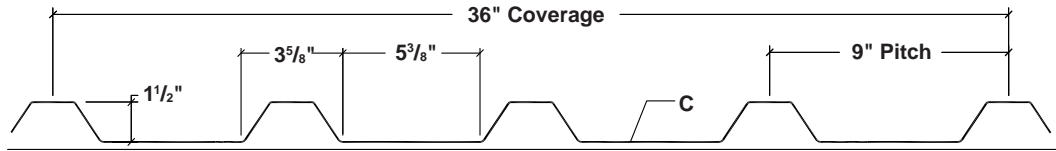

WALL PANEL

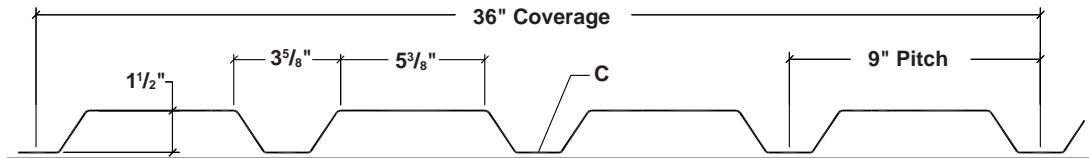

ARCHITECTURAL
COMMERCIAL
INDUSTRIAL
PANEL

DIRECT FASTENED
(EXPOSED)

36"
COVERAGE

MINIMUM
1:12 SLOPE

OPEN FRAMING OR
SOLID SUBSTRATE

PANEL OVERVIEW

- ▶ Finishes: Kynar 500 (PVDF) standard, optional; multi-pass Kynar, Marblique, Plastisol, Polyester, and MS Colorfast45® (SMP)
- ▶ Gauges: 24ga, 22ga, 20ga, and 18ga
- ▶ 36" panel coverage, 1½" rib height
- ▶ Trapezoidal ribs on 9" centers
- ▶ Optional material availability: Stainless Steel, Weathering Steel, Copper, and Aluminum
- ▶ Custom capabilities include:
 - Crimp curving
 - Curving may be convex, concave, or "S" curves
 - Perforated panels for wind screens and liner panels

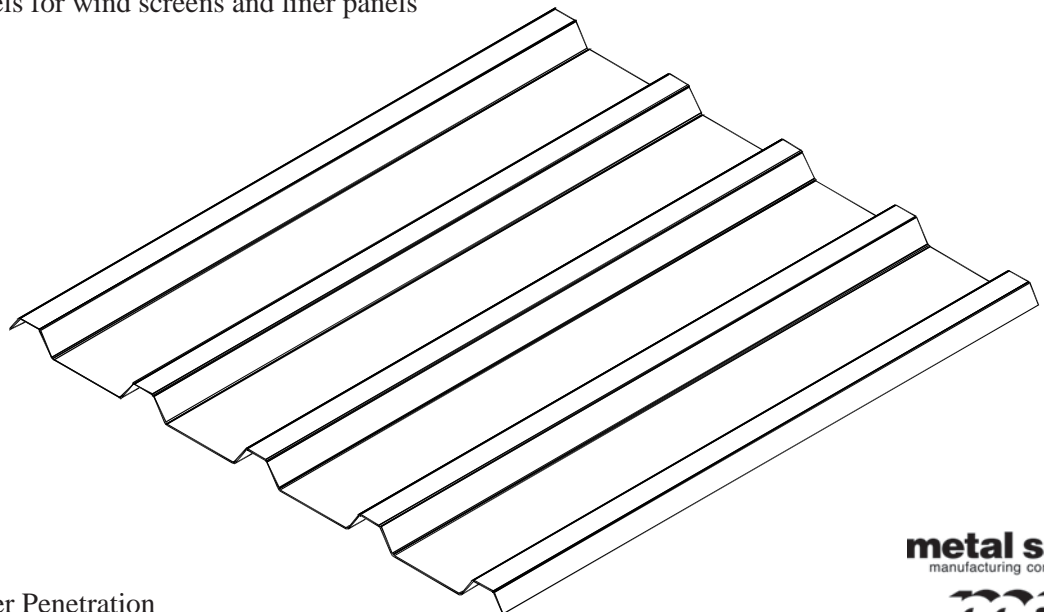

TESTING

- ▶ ASTM E-331 Water Penetration
- ▶ ASTM E-283 Air Infiltration

metal sales
manufacturing corporation



T7 PANEL

ATTACHMENT DETAIL

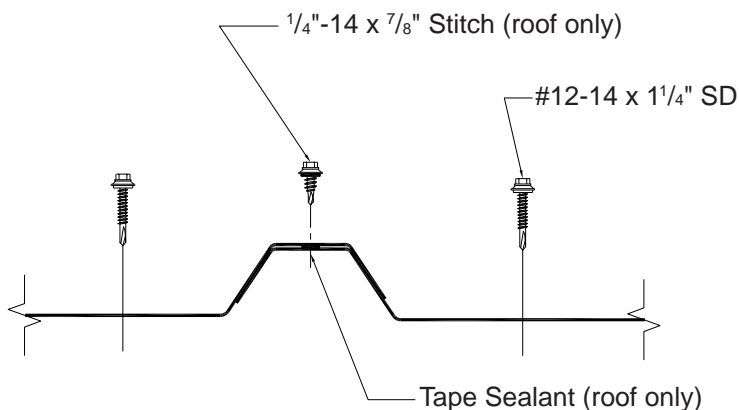

FASTENING PATTERNS

Fastening Pattern (Ends)

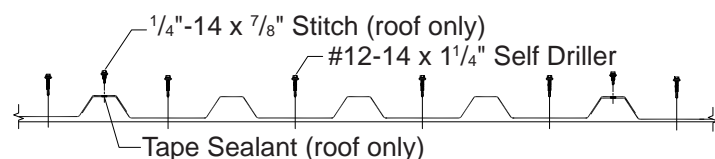

Fastening Pattern (Field)

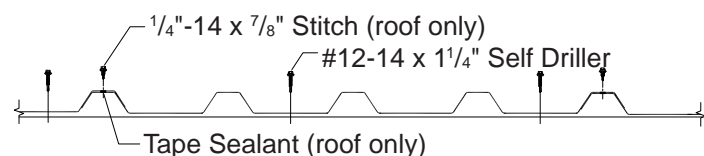

GENERAL INFORMATION

► Substructure

T7 Panel is designed to be utilized over open structural framing or a solid substrate.

► Coverage

T7 Panels are available in a 1 1/2" rib height with a 36" width coverage.

► Length

Minimum factory cut length is 5'-0".
Maximum recommended panel length is 36'-0".

► Fasteners

The fastener selection guide should be consulted for choosing the proper fastener for specific applications. Quantity and type of fastener must meet necessary loading and code requirements.

NOTE: All panels are subject to surface distortion due to improperly applied fasteners. Overdriven fasteners will cause stress and induce oil canning across the face of the panel at or near the point of attachment.

► Availability

Finishes: Kynar 500 (PVDF) standard; optional: multi-pass Kynar, Marblique, Plastisol, Polyester, and MS Colorfast45® (SMP)
Gauges: 24ga, 22ga, 20ga, and 18ga

SECTION PROPERTIES

ALLOWABLE UNIFORM LIVE LOADS PSF (3 or More Equal Spans)

Ga.	Width (in.)	Yield KSI	Weight PSF	Top in Compression		Bottom in Compression		Inward (Gravity / Deflection) Load						Outward Uplift (Stress) Load					
				Ixx In ⁴ /ft	Sxx In ³ /ft	Ixx In ⁴ /ft	Sxx In ³ /ft	5'	6'	7'	8'	10'	12'	5'	6'	7'	8'	10'	12'
24	36"	50	1.26	0.1057	0.1021	0.0700	0.0805	74	51	38	29	17	10	123	86	64	49	31	22
22	36"	50	1.64	0.1533	0.1512	0.1000	0.1216	112	78	57	44	25	14	184	129	95	73	47	32
20	36"	33	1.93	0.1967	0.2028	0.1367	0.1752	106	74	54	42	27	19	162	114	84	64	41	29
18	36"	33	2.51	0.2633	0.2720	0.2000	0.2490	150	105	77	59	38	25	218	152	112	86	55	39

- Theoretical section properties have been calculated per AISI 2001 "Specification for the Design of Cold-formed Steel Structural Members." Ixx and Sxx are effective section properties for deflection and bending.
- Allowable load is calculated in accordance with AISI 2001 specifications considering bending, shear, combined bending and shear, deflection, and applicable testing when available. Allowable load considers the worst case of 3 and 4 equal span conditions. Allowable load does not address web crippling or fasteners/support connection and panel weight is not considered.
- Deflection consideration is limited by a maximum deflection ratio of L/180 of span.
- Allowable loads do not include a 1/3 stress increase in uplift.



Kent, WA (800) 431-3470
Temple, TX (800) 543-4415
Longmont, CO (800) 289-7663
Antioch, TN (800) 251-8508
Woodland, CA (800) 759-6019
Rogers, MN (800) 328-9316
Spokane, WA (800) 572-6565

Jefferson, OH (800) 321-5833
Rock Island, IL (800) 747-1206
Sellersburg, IN (800) 999-7777
Jacksonville, FL (800) 394-4419
Orwigsburg, PA (800) 544-2577
Independence, MO (800) 747-0012
Fontana, CA (800) 782-7953

Anchorage, AK (866) 640-7663
Bay City, MI (888) 777-7640
Detroit Lakes, MN (888) 594-1394
Mocksville, NC (800) 228-6119