

MAGNA-LOC 180

Condensed
Technical
Reference

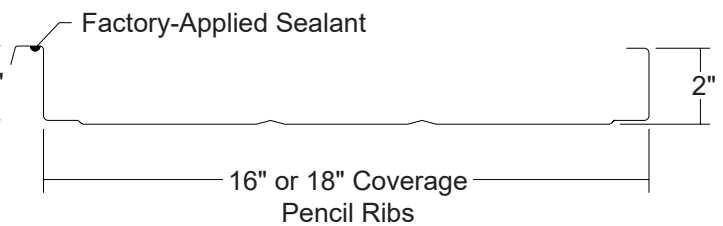
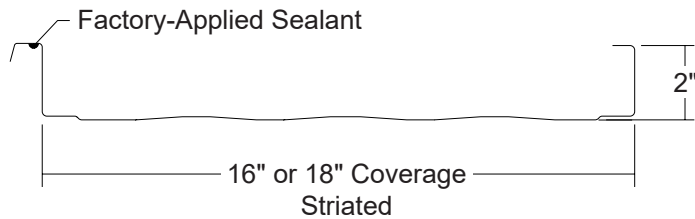
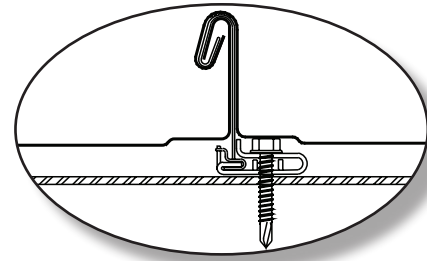
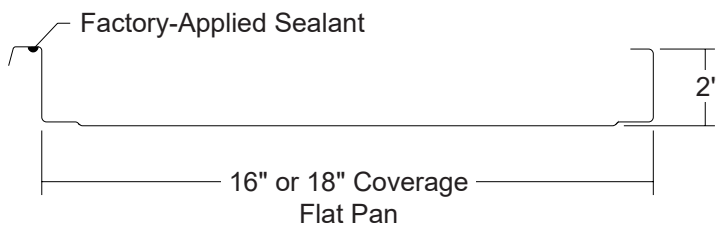

ARCHITECTURAL
COMMERCIAL
INDUSTRIAL
PANEL

CONCEALED
FASTENED

16" OR 18"
COVERAGE

MINIMUM
SLOPE
1/2:12

OPEN FRAMING OR
SOLID SUBSTRATE

PANEL OVERVIEW

- ▶ Finishes: PVDF and Acrylic-Coated Galvalume®
- ▶ Corrosion Protection: AZ55 per ASTM A 792 for unpainted Galvalume®
AZ50 per ASTM A 792 for painted Galvalume®
G90 per ASTM A 653 for Galvanized
- ▶ Gauges: 24 ga standard; 22 ga optional
- ▶ 16" or 18" panel coverage, 2" rib height
- ▶ Panel Length: Minimum: 5' for striated, 7' for non-striated; Maximum: 45' recommended
- ▶ Architectural, structural vertical rib standing seam roof system
- ▶ Integral mechanically seamed side lap with factory-applied sealant
- ▶ Minimum roof slope: 1/2:12
- ▶ Panels can be factory-notched and punched
- ▶ Accommodates 1/2" to 6" blanket insulation

TESTING AND APPROVALS

- ▶ UL 2218 Impact Resistance - Class 4
- ▶ UL 790 Fire Resistance Rating - Class A, per building code
- ▶ UL 263 Fire Resistance Rating - per assembly
- ▶ ASTM E 1680 Air Leakage - 0.015 cfm/ft² at 6.24 psf*
- ▶ ASTM E 1646 Water Penetration - none at 12 psf*
- ▶ ASTM E 2140 Water Penetration, Static head - none*
- ▶ ASTM E 1592 Structural Performance
- ▶ UL 580 Uplift Resistance - Class 90 Constructions: #506, #506A and #506B
- ▶ 2017 FBC Approvals - FL10999.6
- ▶ ICC Evaluation Report - ESR-2385

* with tube sealant at clip locations

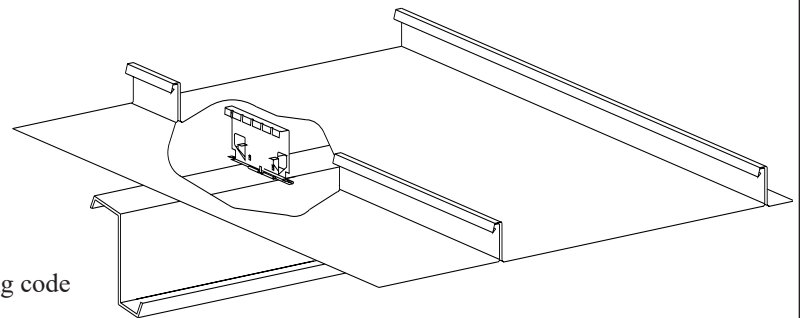

ms metal sales[™]
manufacturing corporation

MAGNA-LOC 180

Condensed
Technical
Reference

ATTACHMENT DETAILS

BEFORE SEAMING

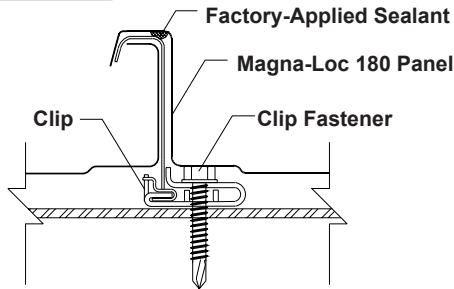

AFTER SEAMING

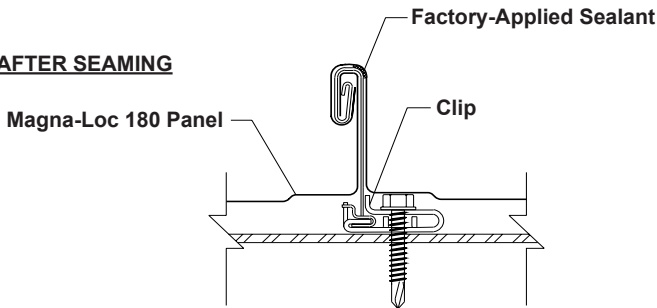

PANEL CLIP

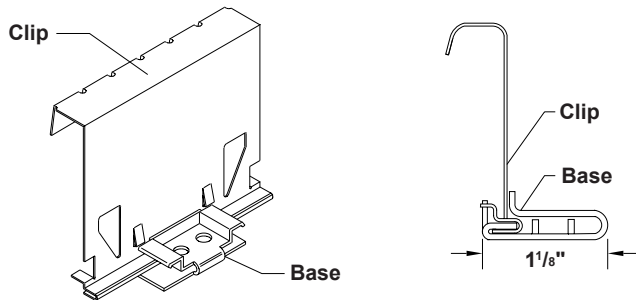

FASTENING INFORMATION

► Clips

Clip spacing is based upon the design loads, the spanning capacity of the panels, the fasteners and the support members.

Clip Tabs are 0.034" thick, G90 is standard, 410 stainless is optional. Clip base is 0.060" thick, G60.

Floating Clips can accommodate 1-1/2" of thermal movement each way.

► Fasteners

Overdriven fasteners will cause panel distortions.

Fasteners should extend 1/2" or more past the inside face of the support material.

Clip Fasteners:

Attaching to Wood:

#12-11 x 1-1/2" Wood Screw

Attaching to Steel:

<18 ga: 1/4"-14 Deck Screw

>=18 ga, <=12 ga: 1/4"-14 Driller, No Washer

>12 ga: 1/4"-24 Driller, No Washer

Exposed End Fasteners:

At Eave Plate or Back-Up Channel:

#12-14 XL Driller

Concealed End Fasteners:

At Eave Plate or Back-Up Channel:

#12-14 Driller, No Washer

Trim Fasteners:

1/4"-14 x 7/8" XL Stitch Screw

1/8" x 3/16" Pop Rivet

SECTION PROPERTIES

Ga	Width in	Yield ksi	Weight psf	Top In Compression		Bottom In Compression	
				Ixx in ⁴ /ft	Sxx in ³ /ft	Ixx in ⁴ /ft	Sxx in ³ /ft
24	16	50	1.24	0.1418	0.0779	0.0720	0.0656
22	16	50	1.63	0.2025	0.1134	0.1005	0.0885
24	18	50	1.21	0.1287	0.0695	0.0640	0.0582
22	18	50	1.58	0.1840	0.1013	0.0893	0.0787

ALLOWABLE UNIFORM LOADS, psf For various clip spacings

								Inward Load					Outward Load						
								2'	2.5'	3'	3.5'	4'	5'	2'	2.5'	3'	3.5'	4'	5'
24	16	50	1.24	0.1418	0.0779	0.0720	0.0656	352	232	164	121	94	60	95	85	75	65	55	35
22	16	50	1.63	0.2025	0.1134	0.1005	0.0885	490	320	224	166	127	82	140	127	114	101	88	63
24	18	50	1.21	0.1287	0.0695	0.0640	0.0582	313	206	145	108	83	54	100	90	80	70	59	39
22	18	50	1.58	0.1840	0.1013	0.0893	0.0787	436	284	199	147	113	73	126	114	103	91	79	56

- Theoretical section properties have been calculated per AISI 2012 'North American Specification for the Design of Cold-Formed Steel Structural Members'. Ixx and Sxx are effective section properties for deflection and bending.
- Allowable loads are calculated in accordance with AISI 2012 specifications considering bending, shear, combined bending and shear, deflection and uplift load testing on 16 ga purlins. Allowable loads consider the 3 or more equal spans condition. Allowable loads do not address web crippling, fasteners or support material. Panel weight is not considered.
- Deflection consideration is limited by a maximum deflection ratio of L/180 of span.
- Allowable loads do not include a 1/3 stress increase for wind.

ms metal sales[™]
manufacturing corporation

metalsales.us.com

Anchorage, AK 866.640.7663
Bay City, MI 888.777.7640
Deer Lake, PA 800.544.2577
Denver, CO 800.289.7663

Detroit Lakes, MN 888.594.1394
Fontana, CA 800.782.7953
Fort Smith, AR 877.452.3915
Independence, MO 800.747.0012

Jacksonville, FL 800.394.4419
Jefferson, OH 800.321.5833
Mocksville, NC 800.228.6119
Nashville, TN 800.251.8508
Rock Island, IL 800.747.1206
Rogers, MN 800.328.9316

Seattle, WA 800.431.3470
Sellersburg, IN 800.999.7777
Sioux Falls, SD 888.902.8320
Spokane, WA 800.572.6565
Temple, TX 800.543.4415
Woodland, CA 800.759.6019