

# VERTICAL SEAM

Condensed  
Technical  
Reference

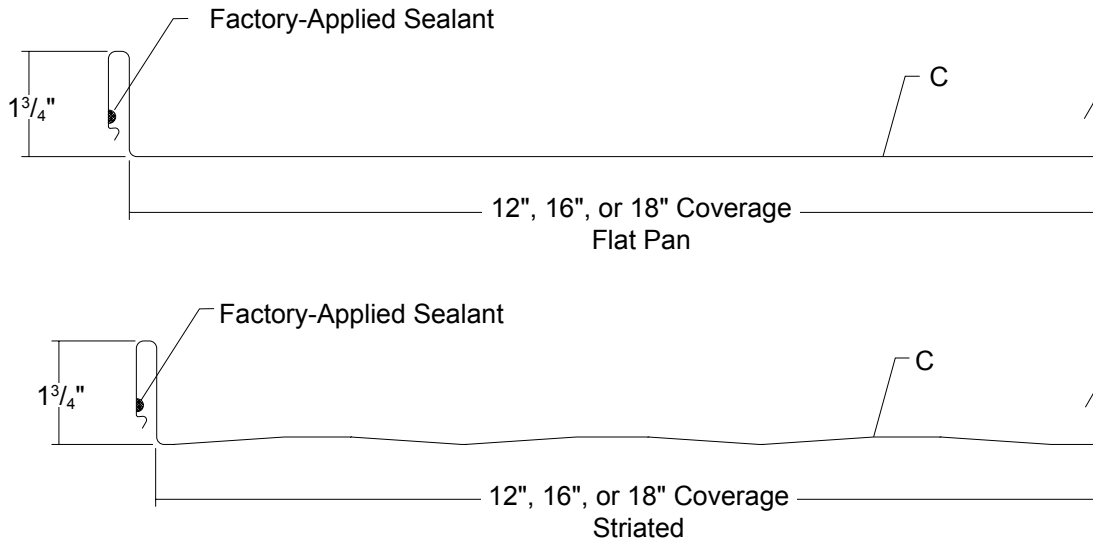

ARCHITECTURAL  
COMMERCIAL  
PANEL

CONCEALED  
FASTENED

12", 16" OR 18"  
COVERAGE

MINIMUM  
SLOPE  
1:12\*

OPEN FRAMING OR  
SOLID SUBSTRATE

## PANEL OVERVIEW

- ▶ Finishes: PVDF, MS Colorfast45<sup>®</sup> and Acrylic-Coated Galvalume<sup>®</sup>
  - ▶ Corrosion Protection: AZ55 per ASTM A 792 for unpainted Galvalume<sup>®</sup>  
AZ50 per ASTM A 792 for painted Galvalume<sup>®</sup>  
G90 per ASTM A 653 for Galvanized
  - ▶ Gauges: 24 ga standard; 26 ga and 22 ga optional
  - ▶ 12", 16" or 18" panel coverage, 1<sup>3</sup>/<sub>4</sub>" rib height
  - ▶ Panel Length: Minimum: 5'; Maximum: 45' recommended
  - ▶ Architectural, structural integral standing seam roof system
  - ▶ Alternate materials include 16 and 20 oz copper and 0.032" aluminum
  - ▶ Snap-together side lap with factory-applied sealant
- \* Minimum roof slope is 1:12 for solid substrates and 3:12 for open framing

## TESTING AND APPROVALS

- ▶ UL 2218 Impact Resistance - Class 4
- ▶ UL 790 Fire Resistance Rating - Class A, per building code
- ▶ UL 263 Fire Resistance Rating - per assembly
- ▶ ASTM E 283 Air Leakage - 0.035 cfm/ft<sup>2</sup> at 1.57 psf
- ▶ ASTM E 331 Water Penetration - none at 12 psf
- ▶ ASTM E 1680 Air Leakage - 0.0036 cfm/ft<sup>2</sup> at 6.24 psf
- ▶ ASTM E 1646 Water Penetration - none at 6.24 psf
- ▶ ASTM E 1592 Structural Performance
- ▶ UL 580 Uplift Resistance - Class 90 Constructions: #436, #446 and #448
- ▶ Texas Windstorm - Evaluation RC-412
- ▶ 2014 FBC Approvals - FL11560.10, FL11560.11 and FL 11560.12
- ▶ Miami-Dade County, Florida - NOA 13-0905.05, expires 3/8/2019
- ▶ ICC Evaluation Report - ESR-2385

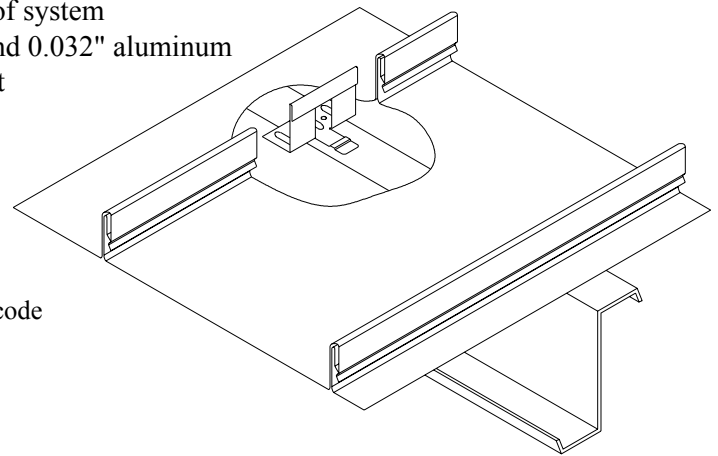

**ms metal sales**<sup>™</sup>  
manufacturing corporation

# VERTICAL SEAM

**Condensed  
Technical  
Reference**

## ATTACHMENT DETAIL

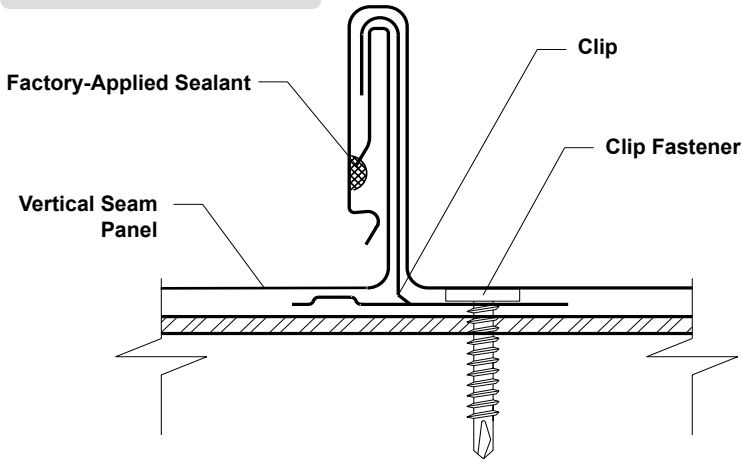

## PANEL CLIP

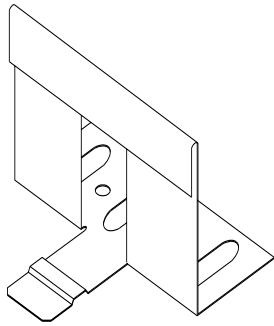

**UL90 CLIP**  
2 Fasteners

## FASTENING INFORMATION

### ► Clips

1. Clip spacing is based upon the design loads, the spanning capacity of the panels, the fasteners and the support members.
2. Clips are 0.050" thick. G90 is standard, 304 stainless is optional. 2 fastener holes is standard, 3 holes is optional.
3. Clips can accommodate practically unlimited thermal movement.

### ► Fasteners

1. Overdriven fasteners will cause panel distortions.
2. Fasteners to wood and steel should extend 1/2" or more past the inside face of the support material.

#### Clip Fasteners and Concealed End Fasteners:

##### Attaching to Wood:

#10-12 Pancake Head Wood Screw

##### Attaching to Steel:

<18 ga: 1/4"-14 Deck Screw

>=18 ga, <=12 ga: #10-16 Pancake Head Driller

##### Attaching to Concrete:

3/16" or 1/4" TapCon, Phillips Flat Head

#### Exposed End Fasteners:

##### Attaching to Wood:

#10-14 XL Wood Screw

##### Attaching to Steel:

#12-14 XL Driller

#### Trim Fasteners:

1/4"-14 x 7/8" XL Stitch Screw

1/8" x 3/16" Pop Rivet

## SECTION PROPERTIES

Ga	Width in	Yield ksi	Weight psf	Top In Compression		Bottom In Compression		ALLOWABLE UNIFORM LOADS, psf For various clip spacings											
				Ixx in <sup>4</sup> /ft	Sxx in <sup>3</sup> /ft	Ixx in <sup>4</sup> /ft	Sxx in <sup>3</sup> /ft	Inward Load			Outward Load								
								2.5'	3'	3.5'	4'	4.5'	5'	2.5'	3'	3.5'	4'	4.5'	5'
26	12	50	1.06	0.0781	0.0530	0.0377	0.0408	148	104	77	59	-	-	55	49	42	36	-	-
26	16	50	0.97	0.0614	0.0402	0.0283	0.0306	114	79	58	45	-	-	55	49	42	36	-	-
26	18	50	0.94	0.0553	0.0358	0.0253	0.0273	-	-	-	-	-	-	-	-	-	-	-	-
24	12	50	1.38	0.1118	0.0774	0.0533	0.0557	204	143	105	81	64	52	44	43	42	41	40	39
24	16	50	1.26	0.0885	0.0589	0.0398	0.0419	153	107	79	61	48	39	42	38	34	30	27	24
24	18	50	1.22	0.0800	0.0526	0.0353	0.0372	136	95	70	54	43	35	33	30	27	24	20	19
22	12	50	1.81	0.1533	0.1071	0.0773	0.0771	284	198	146	112	89	72	69	67	65	62	60	58
22	16	50	1.66	0.1230	0.0822	0.0585	0.0579	213	149	110	84	66	54	54	51	48	45	36	35
22	18	50	1.60	0.1113	0.0736	0.0520	0.0515	190	132	97	75	59	48	31	30	29	29	28	27

1. Theoretical section properties have been calculated per AISI 2012 'North American Specification for the Design of Cold-Formed Steel Structural Members'. Ixx and Sxx are effective section properties for deflection and bending.
  2. Allowable loads are calculated in accordance with AISI 2012 specifications considering bending, shear, combined bending and shear, deflection and ASTM E 1592 uplift testing for 24 ga and 22 ga and UL 580 uplift testing for 26 ga. Allowable loads consider the 3 or more equal spans condition. Allowable loads do not address web crippling, fasteners or support material. Panel weight is not considered.
  3. Deflection consideration is limited by a maximum deflection ratio of L/180 of span.
  4. Allowable loads do not include a 1/3 stress increase for wind.
- Indicates that no testing is available for the application.

**ms metal sales**<sup>™</sup>  
manufacturing corporation

[metalsales.us.com](http://metalsales.us.com)

Anchorage, AK 866.640.7663  
Bay City, MI 888.777.7640  
Deer Lake, PA 800.544.2577  
Denver, CO 800.289.7663

Detroit Lakes, MN 888.594.1394  
Fontana, CA 800.782.7953  
Fort Smith, AR 877.452.3915  
Independence, MO 800.747.0012

Jacksonville, FL 800.394.4419  
Jefferson, OH 800.321.5833  
Mocksville, NC 800.228.6119  
Nashville, TN 800.251.8508  
Rock Island, IL 800.747.1206  
Rogers, MN 800.328.9316

Seattle, WA 800.431.3470  
Sellersburg, IN 800.999.7777  
Sioux Falls, SD 888.902.8320  
Spokane, WA 800.572.6565  
Temple, TX 800.543.4415  
Woodland, CA 800.759.6019