

SOFFIT PANEL

Condensed
Technical
Reference

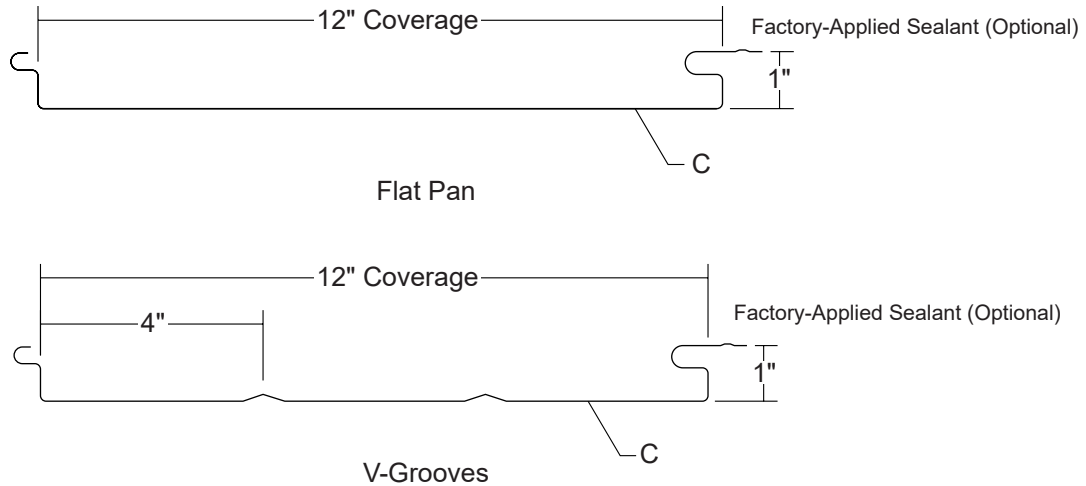

ARCHITECTURAL
COMMERCIAL
INDUSTRIAL
PANEL

CONCEALED
FASTENED

12"
COVERAGE

SOFFIT, FASCIA,
WALL OR LINER
APPLICATIONS

OPEN FRAMING OR
SOLID SUBSTRATE

PANEL OVERVIEW

- ▶ Finishes: Standard: PVDF, MS Colorfast45[®] and Acrylic-Coated Galvalume[®]
- ▶ Corrosion Protection: AZ55 per ASTM A 792 for unpainted Galvalume[®]
AZ50 per ASTM A 792 for painted Galvalume[®]
G90 per ASTM A 653 for Galvanized
- ▶ Gauges: 26 ga and 24 ga and 22 ga
- ▶ 12" panel coverage, 1" panel depth
- ▶ Panel Length: 26 ga: 5' maximum and 5' minimum
24 ga: 20' maximum and 5' minimum
22 ga: 20' maximum and 5' minimum
- ▶ Applies over open framing or solid substrate
- ▶ Concealed, direct fastened panel for soffit, fascia, wall and liner applications
- ▶ Panels can be installed horizontally or vertically
- ▶ Tongue-and-groove sidelap

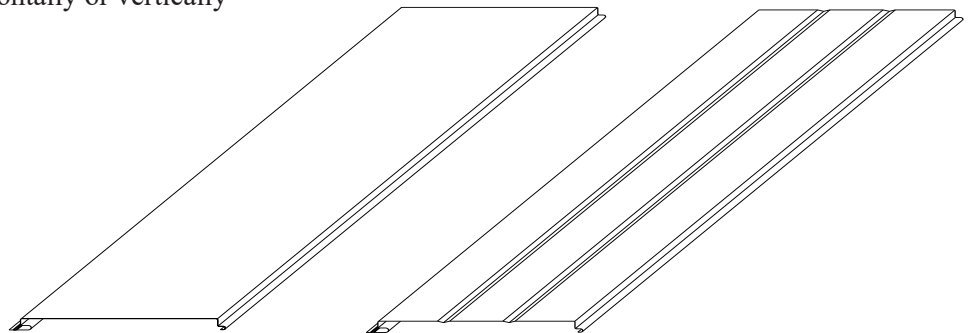

TESTING AND APPROVALS

- ▶ UL 263 Fire Resistance Rating - per assembly
- ▶ ASTM E 283 Air Leakage - 0.25 cfm/ft² at 6.24 psf
- ▶ ASTM E 331 Water Penetration - none at 12 psf
- ▶ ASTM E 330 Structural Performance
- ▶ 2020 FBC Approval - FL9482.5

MS metal sales[™]
manufacturing corporation

SOFFIT PANEL

**Condensed
Technical
Reference**

SIDELAP FASTENING DETAIL

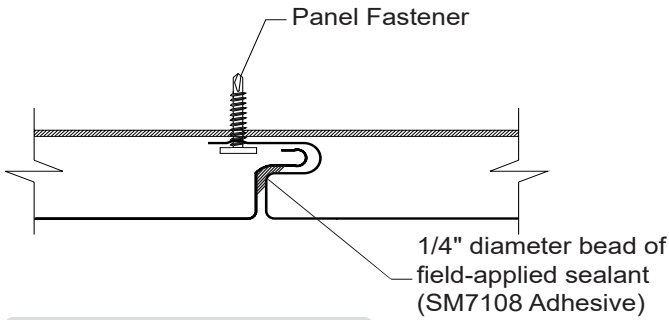

SIDELAP INSTALLATION

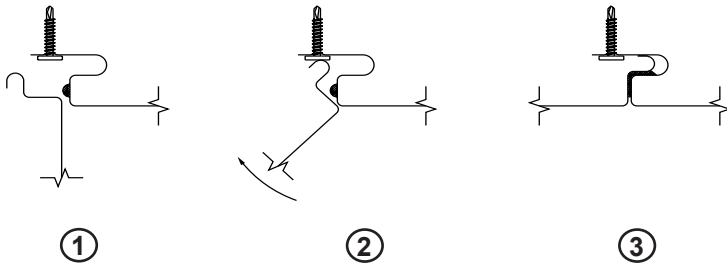

VERTICAL DIRECTIONAL DETAILS

Left to Right Installation



Right to Left Installation



FASTENER INFORMATION

Overdriven fasteners will cause panel distortions.

Fasteners should extend 1/2" or more past the inside face of the support material.

Thick panels (ex. 18 ga) or supports (ex. 1/2" steel) may require predrilling of holes for screws.

Panel Fasteners:

Attaching to Wood:

#10-12 Pancake Head Wood Screw

Attaching to Steel:

≤12 ga: #10-16 Pancake Head Drilller

Trim Fasteners:

1/4"-14 x 7/8" XL Stitch Screw

1/8" x 3/16" Pop Rivet

Field-Applied Sealant:

1/4" bead of SM7108

Panels must be engaged before sealant has cured.

HORIZONTAL DIRECTIONAL DETAIL

Top to Bottom Installation



SECTION PROPERTIES

ALLOWABLE UNIFORM LOADS, psf For various fastener spacings

Ga	Width in	Yield ksi	Weight psf	Top In Compression		Bottom In Compression		Inward Load					Outward Load						
				I _{xx} in ⁴ /ft	S _{xx} in ³ /ft	I _{xx} in ⁴ /ft	S _{xx} in ³ /ft	2'	2.5'	3'	3.5'	4'	5'	2'	2.5'	3'	3.5'	4'	5'
26	12	50	0.94	0.0130	0.0226	0.0290	0.0339	144	100	74	55	42	27	-	-	-	-	-	-
24	12	50	1.23	0.0189	0.0338	0.0410	0.0480	178	129	97	75	60	40	55	55	55	55	55	-
22	12	50	1.62	0.0278	0.0520	0.0560	0.0651	234	170	129	100	80	54	55	55	55	55	55	-

- Theoretical section properties have been calculated per AISI 2016 'North American Specification for the Design of Cold-Formed Steel Structural Members'. I_{xx} and S_{xx} are effective section properties for deflection and bending.
- Allowable load is calculated in accordance with AISI 2016 specifications considering bending, shear, combined bending & shear and deflection. Allowable load does not address web crippling, fasteners, support material or load testing. Allowable load considers the three or more equal spans condition. Panel weight is not considered.
- Deflection consideration is limited by a maximum deflection ratio of L/180 of span.
- Allowable loads do not include a 1/3 stress increase for wind.

ms metal sales™
manufacturing corporation

metalsales.us.com

Anchorage, AK 866.640.7663
Bay City, MI 888.777.7640
Deer Lake, PA 800.544.2577
Denver, CO 800.289.7663

Detroit Lakes, MN 888.594.1394
Fontana, CA 800.782.7953
Fort Smith, AR 877.452.3915
Independence, MO 800.747.0012

Jacksonville, FL 800.394.4419
Jefferson, OH 800.321.5833
Mocksville, NC 800.228.6119
Nashville, TN 800.251.8508
Rock Island, IL 800.747.1206
Rogers, MN 800.328.9316

Seattle, WA 800.431.3470
Sellersburg, IN 800.999.7777
Sioux Falls, SD 888.299.0024
Spokane, WA 800.572.6565
Temple, TX 800.543.4415
Woodland, CA 800.759.6019

©MSMC/1-2021