

3" T-ARMOR

Condensed
Technical
Reference



Flat



Pencil Rib

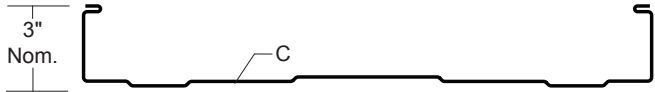

Mesa

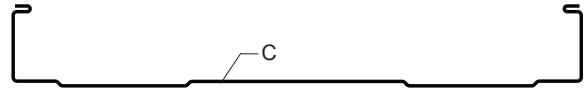

Plank

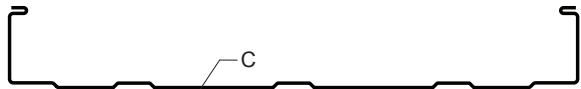

Minor Rib

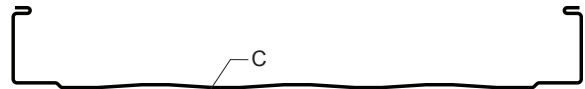

Striated

*Profiles are shown for 16" wide panels. Other width panels are similar.

ARCHITECTURAL
COMMERCIAL
INDUSTRIAL
PANEL

CONCEALED
FASTENED

12", 16" OR 18"
COVERAGE

MINIMUM
SLOPE
1/2:12

OPEN FRAMING OR
SOLID SUBSTRATE

PANEL OVERVIEW

- ▶ Finishes: PVDF and Acrylic-Coated Galvalume®
- ▶ Corrosion Protection: AZ55 per ASTM A 792 for unpainted Galvalume®
AZ50 per ASTM A 792 for painted Galvalume®
G90 per ASTM A 653 for Galvanized
- ▶ Thickness: 24 ga and 22 ga
- ▶ 12", 16" or 18" panel coverage, 3" rib height
- ▶ Panel Length: Minimum: 6', Maximum: 80'
- ▶ Architectural, structural vertical rib standing seam roof system
- ▶ Integral mechanically seamed side lap with factory-applied sealant
- ▶ Minimum roof slope: 1/2:12
- ▶ Accommodates 1/2" to 6" blanket insulation

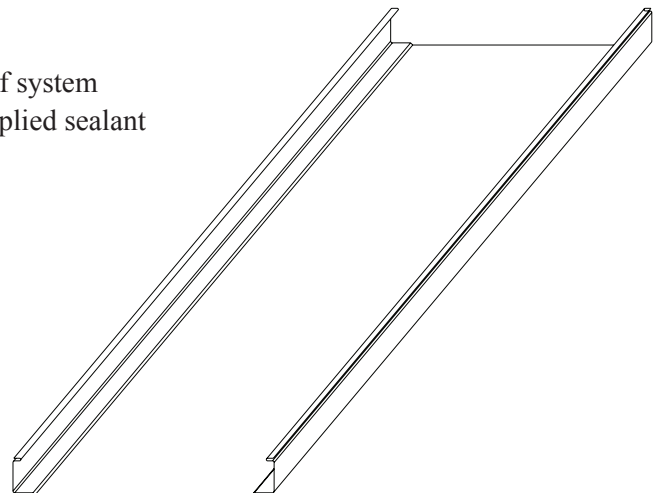

TESTING AND APPROVALS

- ▶ UL 2218 Impact Resistance - Class 4
- ▶ UL 790 Fire Resistance Rating - Class A, per building code
- ▶ UL 263 Fire Resistance Rating - per assembly
- ▶ ASTM E 1592 Structural Performance
- ▶ ICC Evaluation Report - ESR-3743

MS Metal Sales™

3" T-ARMOR

ATTACHMENT DETAILS

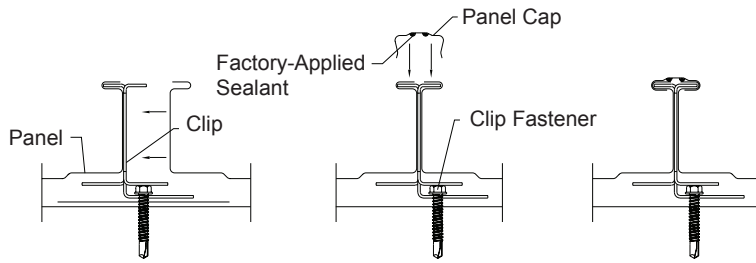

INSTALLING PANEL

INSTALLING CAP

SEAMED

CLIP OPTIONS

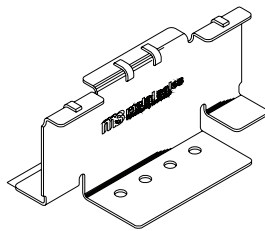

INDIVIDUAL CLIP

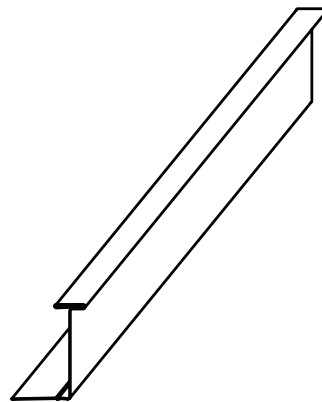

CONTINUOUS CLIP

FASTENING INFORMATION

► Clips

Clip spacing is based upon the design loads, the spanning capacity of the panels, the fasteners and the support members.

Individual clips are 0.060" thick, G90 is standard, 410 stainless is optional. Continuous clips are 24 or 22 ga.

Both Individual and continuous clips can accommodate practically unlimited thermal movement in each direction.

► Fasteners

Overdriven fasteners will cause panel distortions.

Fasteners should extend 1/2" or more past the inside face of the support material.

Clip Fasteners:

Attaching to Wood:

#12-11 x 1-1/2" Wood Screw

Attaching to Steel:

<18 ga: 1/4"-14 Deck Screw

>=18 ga, <=12 ga: 1/4"-14 Driller, No Washer

>12 ga: 1/4"-24 Driller, No Washer

Exposed End Fasteners:

At Eave Plate or Back-Up Channel:

#12-14 XL Driller

Concealed End Fasteners:

At Eave Plate or Back-Up Channel:

#12-14 Driller, No Washer

Trim Fasteners:

1/4"-14 x 7/8" XL Stitch Screw

1/8" x 3/16" Pop Rivet

STEEL SECTION PROPERTIES

Ga	Width in	Yield ksi	Weight psf	Top In Compression		Bottom In Compression		ALLOWABLE UNIFORM LOADS, psf (3 or More Equal Spans)											
				Ixx in ⁴ /ft	Sxx in ³ /ft	Ixx in ⁴ /ft	Sxx in ³ /ft	Inward Load					Outward Load						
								2'	2.5'	3'	3.5'	4'	5'	2'	2.5'	3'	3.5'	4'	5'
24	12	50	1.60	0.5756	0.2723	0.3676	0.2442	400	400	379	305	251	178	51	47	44	41	37	31
22	12	50	2.10	0.7900	0.3776	0.5290	0.3434	400	400	400	400	400	284	51	47	44	41	37	31
24	16	50	1.43	0.4665	0.2063	0.2235	0.1328	400	323	247	194	157	107	51	47	44	41	37	31
22	16	50	1.87	0.6428	0.2869	0.3195	0.1964	400	400	400	325	256	170	51	47	44	41	37	31
24	18	50	1.37	0.4260	0.1839	0.1987	0.1177	389	287	219	173	139	95	51	47	44	41	37	31
22	18	50	1.80	0.5887	0.2560	0.2840	0.1743	400	400	376	288	228	151	51	47	44	41	37	31

- Theoretical section properties have been calculated per AISI 2016 'North American Specification for the Design of Cold-Formed Steel Structural Members'. Ixx and Sxx are effective section properties for deflection and bending.
- Allowable load is calculated in accordance with AISI 2016 specifications considering bending, shear, combined bending and shear and deflection. Allowable load considers the 3 or more equal spans condition. Allowable load does not address web crippling, fasteners, support material or load testing. Panel weight is not considered.
- Deflection consideration is limited by a maximum deflection ratio of L/180 of span.
- Allowable loads do not include a 1/3 stress increase for wind.