

**EVALUATION REPORT OF
METAL SALES MANUFACTURING CORPORATION
'ALUMINUM MAGNA-LOC PANEL'**

**FLORIDA BUILDING CODE 7TH EDITION (2020)
FLORIDA PRODUCT APPROVAL
FL 10999.2-R4
STRUCTURAL COMPONENTS
ROOF DECK**

**Prepared For:
Metal Sales Manufacturing Corporation
545 South 3rd Street, Suite 200
Louisville, KY 40202
Telephone: (502) 855-4300
Fax: (502) 855-4200**

**Prepared By:
Bala Sockalingam, Ph.D., P.E.
Florida Professional Engineer #62240
1216 N Lansing Ave., Suite C
Tulsa, OK 74106
Telephone: (918) 492-5992
FAX: (866) 366-1543**

**This report consists of
Evaluation Report (3 Pages including cover)
Installation Details (2 Pages)
Load Span Table (1 Page)**

**Report No. C2394-2
Date: 9.28.2020**

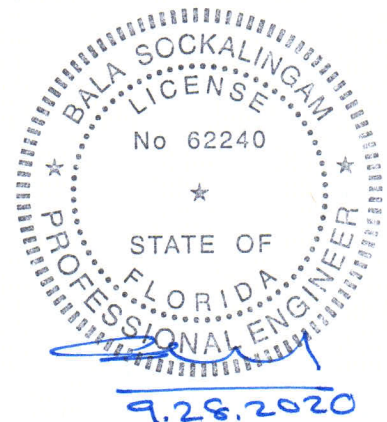

Manufacturer: Metal Sales Manufacturing Corporation

Product Name: Aluminum Magna-Loc

Panel Description: Standing seam panel with max. 16" wide coverage and 2" high ribs

Materials: Nominal 0.032" thick 3003-H14 or 3105-H24 Alloy (ASTM B209) as per FBC 2020 Section 1507.4.3.

Support Description: Min 22 ga., 50 ksi steel section or deck. The support or deck and their connections must be designed by other to carry the panel loads.

Insulation: (Optional) Max. 4" thick rigid board insulation in accordance with FBC 2020 Section 1508.2. Used with steel decks.

Slope: 1/4:12 or greater in accordance with FBC 2020 Section 1507.4.2.

Design Uplift Pressure: 30.0 psf at clip spacing of 60" o.c. for 0.032" thick panel
87.5 psf at clip spacing of 12" o.c. for 0.032" thick panel

Panel Attachment: MC 1203 clip with stainless steel clip tab. For supports equal to or greater than 16 ga., the clips are fastened with (2) 1/4"-14 self-drilling screws. For supports equal to or less than 18 ga., the clips are fastened with (2) Trufast HD #14 roofing fasteners. For steel decks, the clips are fastened with (2) Trufast HD #14 roofing fasteners through 4" x 5" x 20 ga. bearing plate and rigid insulation into deck. Fastener shall be of sufficient length to penetrate through the deck a minimum of 3/8". Clips and fasteners are corrosion resistant as per FBC 2020 Section 1506.7 and 1507.4.4, respectively.

Test Standards: Roof assembly tested in accordance with ASTM E1592-05(2012) 'Test Method for Structural Performance of Sheet Metal Roof and Siding Systems by Uniform Static Air Pressure Difference' and FM 4470 Section 5.5 'Resistance to Foot Traffic'.

Test Equivalency: The test procedure in FM 4470 (1992) comply with test procedure prescribed in FM 4470 (2016) Section 4.6 'Resistance to Foot Traffic'.

Code Compliance: The product described herein has demonstrated compliance with FBC 2020 Section 1507.4.

Product Limitations: Design wind loads shall be determined for each project in accordance with FBC 2020 Section 1609 or ASCE 7-16 using allowable stress design. The maximum support spacing listed herein shall not be exceeded. The design pressure for reduced clip spacing may be computed using rational analysis prepared by a Florida Professional

Engineer or based on Metal Sales load span table. This evaluation report is not applicable in High Velocity Hurricane Zone. Fire classification is not within scope of this Evaluation Report. Refer to FBC 2020 Section 1505 and current approved roofing materials directory or ASTM E108/UL790 report from an accredited laboratory for fire ratings of this product.

Supporting Documents: ASTM E1592 Test Reports
ENCON Technology Inc.
C1718-1, Reporting Date 6/30/10

FM 4470 Test Report
ENCON Technology Inc
C1587-4, Reporting Date 6/30/08

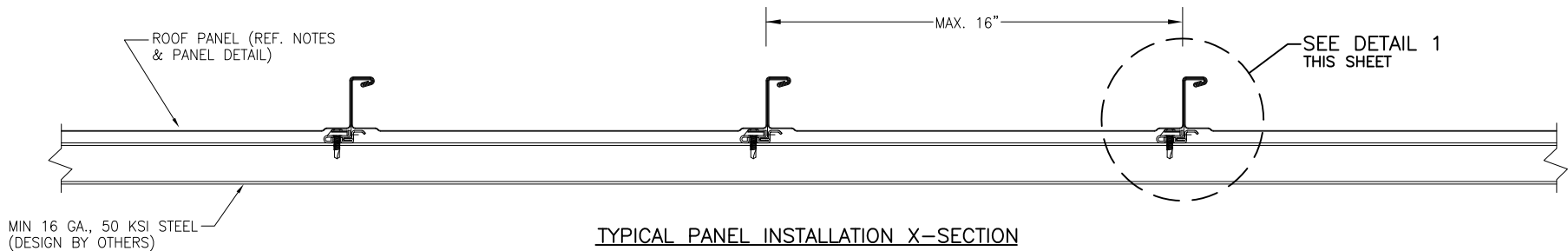

TYPICAL PANEL INSTALLATION X-SECTION

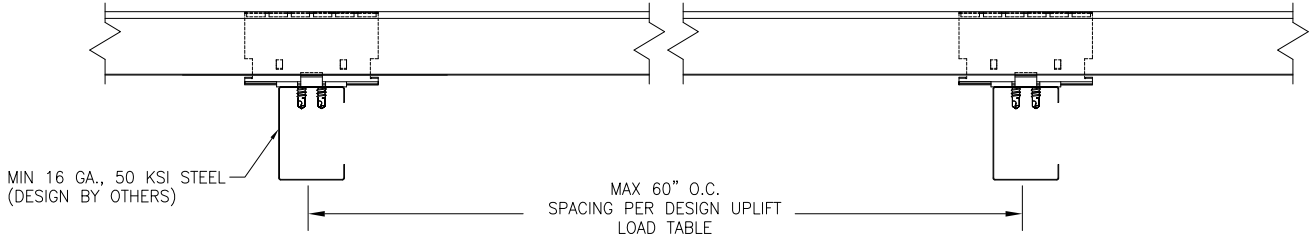

TYPICAL SIDE VIEW

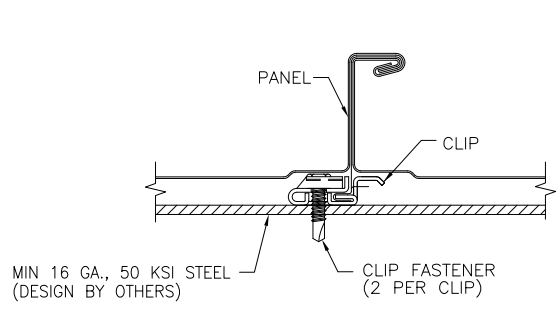

CLIP SECTION VIEW

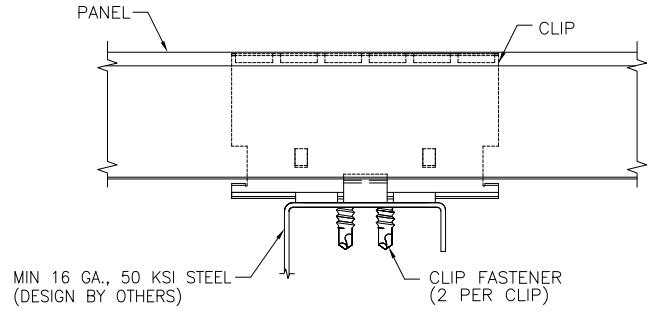

CLIP SIDE VIEW

DETAIL 1

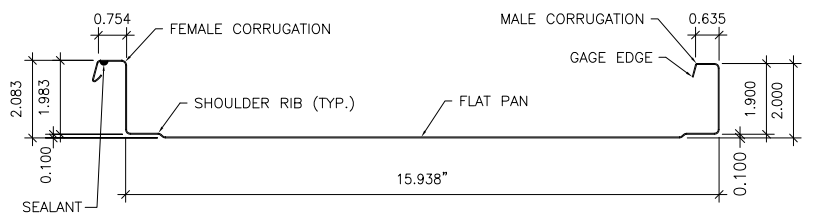

PANEL SECTION
(MIN 0.032" THICK ALUMINUM)

GENERAL NOTES:

1. STRUCTURAL ROOF PANEL HAS BEEN DESIGNED IN ACCORDANCE WITH THE FLORIDA BUILDING CODE (FBC).
2. ROOF PANELS SHALL BE MIN. 0.032" THICK ALUMINUM (3003-H14 OR 3105-H24). MAX. EFFECTIVE COVERING WIDTH OF PANEL = 16".
3. THE ROOF PANELS SHALL BE INSTALLED OVER STRUCTURE AS SPECIFIED ON THESE DRAWINGS.
4. REQUIRED DESIGN WIND LOADS SHALL BE DETERMINED FOR EACH PROJECT. THIS PANEL SYSTEM MAY NOT BE INSTALLED WHEN THE REQUIRED DESIGN WIND LOADS ARE GREATER THAN THE ALLOWABLE WIND LOADS SPECIFIED ON THESE DRAWINGS.
5. CLIPS AND FASTENERS MUST BE IN ACCORDANCE WITH THIS DRAWING & FLORIDA BUILDING CODE. IF A DIFFERENCE OCCURS BETWEEN THE MINIMUM REQUIREMENTS OF THESE DRAWINGS & THE CODE, THE CODE SHALL CONTROL.
6. PURLINS/JOISTS/TRUSSES MUST BE DESIGNED TO WITHSTAND WIND LOADS AS REQUIRED FOR EACH APPLICATION AND ARE THE RESPONSIBILITY OF OTHERS.

| | |
|---|----------------------|
| DRAWN BY: B.S. | CHECKED BY: D.S. |
| DATE: 9/25/20 | |
| NO. | REVISION DESCRIPTION |
| BY | DATE |
| DRAWING TITLE ALUMINUM MAGNA-LOC STANDING SEAM ROOF PANEL | |
| CONSULTANTS BALA SOCKALINGAM, PH.D., P.E. | |
| MANUFACTURER METAL SALES MANUFACTURING CORP. | |
| 1216 N LANSING AVE, SUITE C TULSA, OK 74106 PHONE: 918-492-5992 FAX: 866-366-1943 | |
| 545 SOUTH 3RD ST., SUITE 200 LOUISVILLE, KY 40202 502-855-4300 | |
| DRAWING NO. 2394-2A | REV. |
| PAGE NO. 1 | OF 2 |

DRAWN BY: B.S. CHECKED BY: D.S.
 PLOT: DATE: 9/25/20

| NO. | REVISION DESCRIPTION | DATE |
|-----|----------------------|------|
| | | |
| | | |
| | | |
| | | |

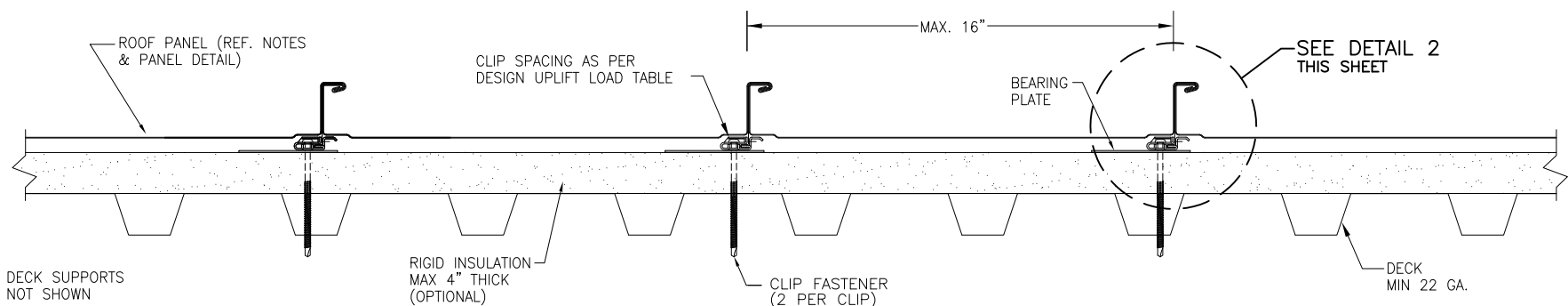

TYPICAL PANEL INSTALLATION X-SECTION

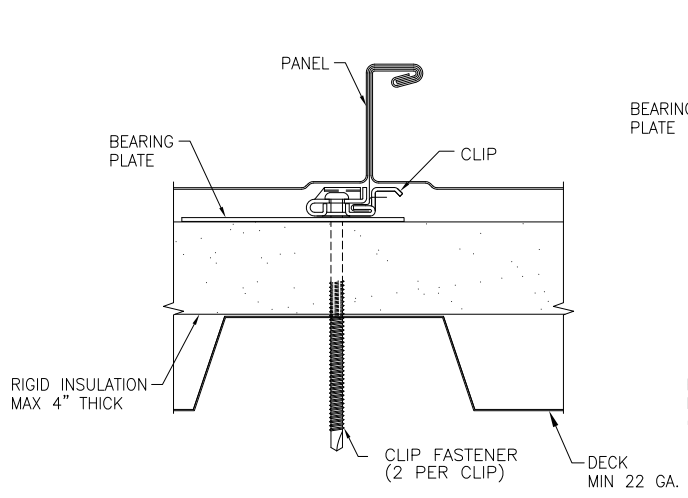

CLIP SECTION VIEW

DETAIL 2

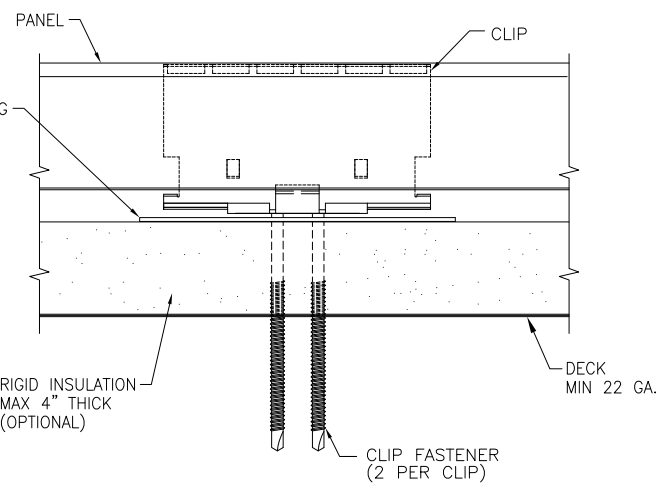

CLIP SIDE VIEW

DRAWING TITLE: ALUMINUM MAGNA-LOC STANDING SEAM ROOF PANEL

CONSULTANTS: **BALA SOCKALINGAM, PH.D., P.E.**
 MANUFACTURER: **METAL SALES MANUFACTURING CORP.**
 545 SOUTH 3RD ST., SUITE 200
 LOUISVILLE, KY 40202
 502-855-4300

1216 N LANSING AVE, SUITE C
 TULSA, OK 74106
 PHONE: 918-492-5992 FAX: 866-366-1543

METAL SALES MANUFACTURING CORPORATION
Aluminum Magna-Loc Panel with Standard Clip
Design Uplift Loads

| Clip spacing along length (in) | Design Uplift Loads (psf) | |
|--------------------------------------|---------------------------|--|
| | 0.032" thick | |
| 12 | 87.5 | |
| 18 | 80.3 | |
| 24 | 73.1 | |
| 30 | 60.0 | |
| 36 | 50.0 | |
| 42 | 42.9 | |
| 48 | 37.5 | |
| 54 | 33.3 | |
| 60 | 30.0 | |

Notes:

1. The bold numbers are based on testing on 0.032" thick aluminum (3003-H14 or 3105-H24) panels.
2. The panels are fastened to support with standard MC clips with stainless steel clips tabs.
3. For supports equal to or less than 18 ga., the clips are fastened with (2) Trufast #14 screws.
4. For supports equal to or greater than 16 ga., the clips are fastened with (2) 1/4"-14 SDS.
5. Panels must be installed as per Evaluation Report FL 10999.2 and Metal Sales current installation procedure.
6. Three or more spans condition.

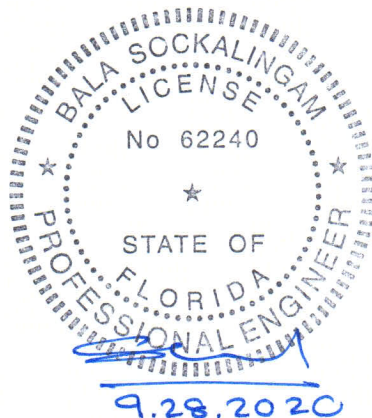

1216 N Lansing Ave., Suite C
Tulsa, Ok 74106
918 492 5992

Bala Sockalingam, Ph.D., P.E.
FL 62240