

**EVALUATION REPORT OF  
METAL SALES MANUFACTURING CORPORATION  
'NOM 0.032" THICK ALUMINUM 5V-CRIMP PANEL'**

**FLORIDA BUILDING CODE 7TH EDITION (2020)  
FLORIDA PRODUCT APPROVAL  
FL 11560.1-R4  
ROOFING  
METAL ROOFING**

**Prepared For:  
Metal Sales Manufacturing Corporation  
545 South 3<sup>rd</sup> Street, Suite 200  
Louisville, KY 40202  
Telephone: (502) 855-4300  
Fax: (502) 855-4200**

**Prepared By:  
Bala Sockalingam, Ph.D., P.E.  
Florida Professional Engineer #62240  
1216 N Lansing Ave., Suite C  
Tulsa, OK 74106  
Telephone: (918) 492-5992  
FAX: (866) 366-1543**

**This report consists of  
Evaluation Report (3 Pages including cover)  
Installation Details (1 Page)  
Load Span Table (1 Page)**

**Report No. C2396-1  
Date: 10.1.2020**

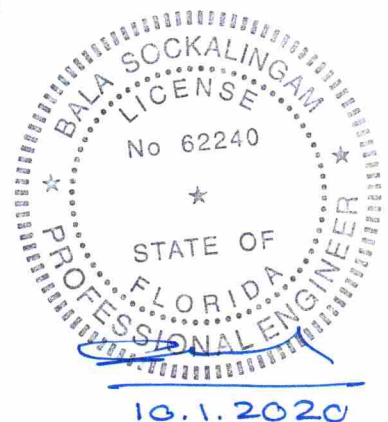

Manufacturer:	Metal Sales Manufacturing Corporation
Product Name:	Aluminum 5V-Crimp
Panel Description:	24" wide coverage with (5) 1/2" high ribs
Materials:	Min. nominal 0.032" thick 3004-H14 or 3105-H24 Alloy (ASTM B209) as per FBC 2020 Section 1507.4.3.
Deck Description:	Min. 7/16" thick OSB, min. 15/32" thick Plywood or min. 3/4" thick wood plank (min SG of 0.42) for new and existing constructions. Designed by others and installed as per FBC 2020.
Deck Attachment: (Minimum)	8d x 2.5" long ring shank nails or #8 x 2" long wood screws @ 6" o.c. in the plywood field and edges. Designed as per FBC 2020.
New Underlayment:	Minimum underlayment as per FBC 2020 Section 1507.4.5.1. Required for new construction and optional for reroofing construction.
Existing Underlayment: (Optional)	One layer of asphalt shingles over one layer of #30 felt. For reroofing construction only.
Slope:	1/2:12 or greater in accordance with FBC 2020 Section 1507.4.2. Requires applied lap sealant for roof slopes less than 3:12.
Design Uplift Pressure: (Factor of Safety = 2)	30 psf @ fastener spacing of 36" o.c. 161.5 psf @ fastener spacing of 6" o.c.
Fastener Pattern: Type:	#10-14 hex head wood screw with sealed washer. Fastener shall be of sufficient length to penetrate through the deck a minimum of 3/8". Fasteners are corrosion resistant as per FBC 2020 Section 1507.4.4.
At panel ends	@ 6" o.c. across panel width
At intermediate	@ max 12.5" o.c. across panel width
Test Standards:	Roof assembly tested in accordance with TAS 125-03 'Standard Requirements for Metal Roofing Systems'.
Code Compliance:	The product described herein has demonstrated compliance with FBC 2020 Section 1507.4.
Product Limitations:	Design wind loads shall be determined for each project in accordance with FBC 2020 Section 1609 or ASCE 7-16 using allowable stress design. The maximum fastener spacing listed herein shall not be exceeded. The design pressure for reduced fastener spacing may be computed using rational analysis prepared by a Florida Professional

Engineer or based on Metal Sales load span table. This evaluation report is not applicable in High Velocity Hurricane Zone. Fire classification is not within scope of this Evaluation Report. Refer to FBC 2020 Section 1505 and current approved roofing materials directory or ASTM E108/UL790 report from an accredited laboratory for fire ratings of this product.

Supporting Documents: TAS 125 Test Reports  
Farabaugh Engineering and Testing Inc.  
Project No. T198-11, Reporting Date 5/19/11

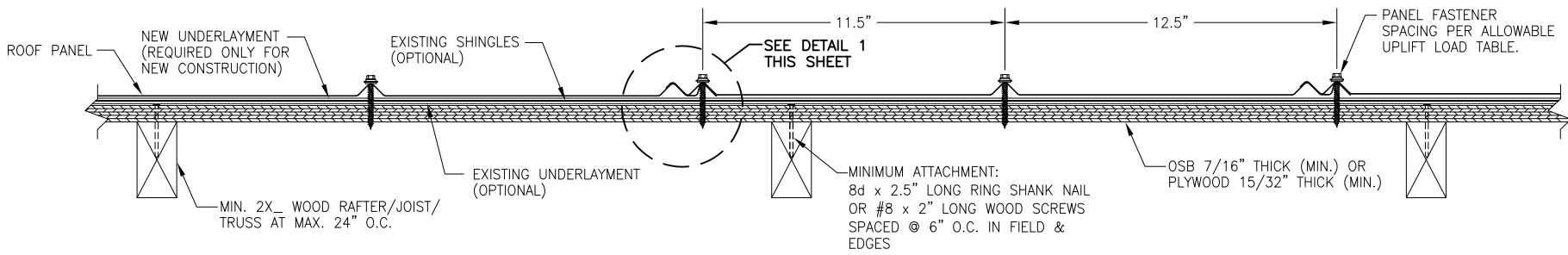

**FASTENER PATTERN AT INTERMEDIATE LOCATIONS**

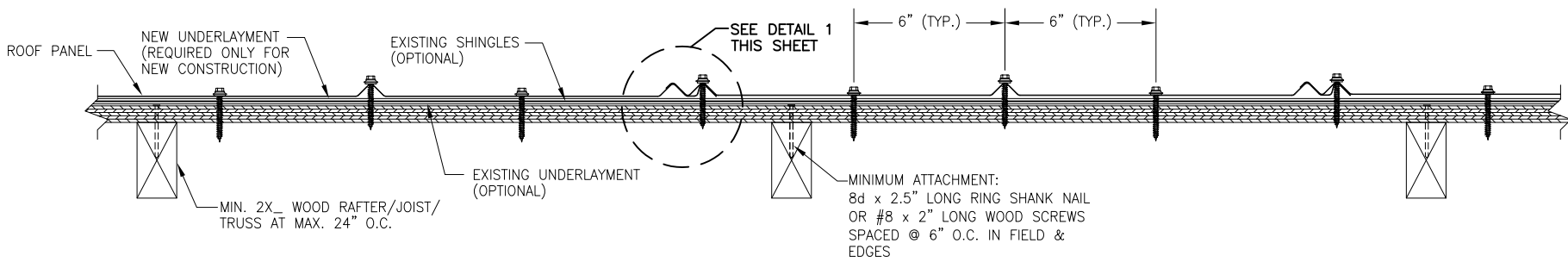

**FASTENER PATTERN AT PANEL ENDS  
TYPICAL PANEL INSTALLATION X-SECTION**

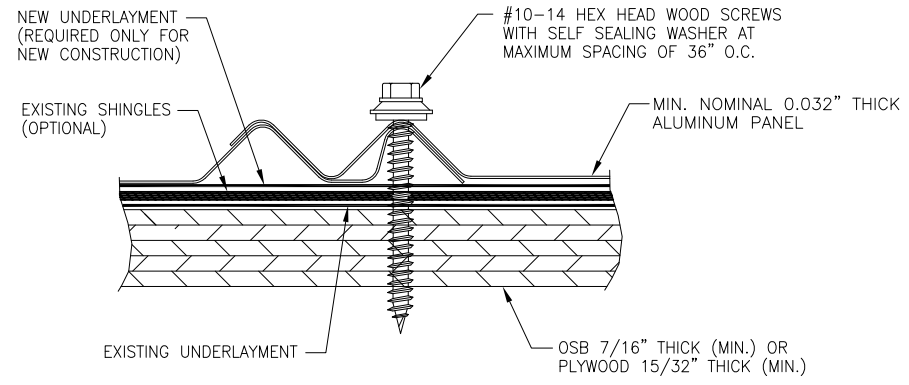

**DETAIL 1**

**GENERAL NOTES:**

1. ARCHITECTURAL ROOF PANEL HAS BEEN DESIGNED IN ACCORDANCE WITH THE FLORIDA BUILDING CODE (FBC).
2. ROOF PANELS ARE SHALL BE MIN. NOMINAL 0.032" THICK ALUMINUM. COVERING WIDTH OF PANEL = 24".
3. THE ROOF PANELS SHALL BE INSTALLED OVER SHEATHING & STRUCTURE AS SPECIFIED ON THIS DRAWING.
4. REQUIRED DESIGN WIND LOADS SHALL BE DETERMINED FOR EACH PROJECT. THIS PANEL SYSTEM MAY NOT BE INSTALLED WHEN THE REQUIRED DESIGN WIND LOADS ARE GREATER THAN THE ALLOWABLE WIND LOADS SPECIFIED ON THIS DRAWING.
5. ALL FASTENERS MUST BE IN ACCORDANCE WITH THIS DRAWING & THE FLORIDA BUILDING CODE. IF A DIFFERENCE OCCURS BETWEEN THE MINIMUM REQUIREMENTS OF THIS DRAWING & THE CODE, THE CODE SHALL CONTROL.
6. RAFTERS/JOISTS/TRUSSES MUST BE DESIGNED TO WITHSTAND WIND LOADS AS REQUIRED FOR EACH APPLICATION AND ARE THE RESPONSIBILITY OF OTHERS.
7. REQUIRES APPLIED LAP SEALANT FOR ROOF SLOPE < 3:12.

DRAWN BY: B.S.	CHECKED BY: D.S.
PLOT:	DATE: 9/30/20
NO.	REVISION DESCRIPTION
BY:	DATE
DRAWING TITLE <b>ALUMINUM 5V-CRIMP PANEL</b>	
CONSULTANTS <b>BALA SOCKALINGAM, PH.D., P.E.</b>	
MANUFACTURER <b>METAL SALES MANUFACTURING CORP.</b>	
1216 N LANSING AVE, SUITE C TULSA, OK 74106	
545 SOUTH 3RD ST., SUITE 200 LOUISVILLE, KY 40202	
PHONE: 918-492-5992 FAX: 866-366-1543	
DRAWING NO. <b>2396-1</b>	REV.
PAGE NO. <b>1</b>	OF <b>1</b>

**METAL SALES MANUFACTURING CORPORATION**  
**Aluminum 5V-Crimp Uplift Loads**  
**(Min. Nominal 0.032" thick)**

Description	Fastener Spacing along Panel Length (in)	Allowable Uplift Load (psf)
Coverage width: 24"  Panel Fastener: #10-14 hex head screws with sealed washer  Panel fasteners spaced at max. 12.5" o.c. across panel width through ribs.	<b>6</b>	<b>161.5</b>
	9	120.0
	12	90.0
	15	72.0
	18	60.0
	21	51.4
	24	45.0
	27	40.0
	30	36.0
	33	32.7
	<b>36</b>	<b>30.0</b>

**Notes:**

1. The bold numbers indicate design loads calculated from test data with safety factor of 2.
2. Panels must be installed as per Evaluation Report FL 11560.1 and Metal Sales current installation procedure.
3. Three or more spans condition.



1216 N Lansing Ave., Suite C  
 Tulsa, Ok 74106  
 918 492 5992

Bala Sockalingam, Ph.D., P.E.  
 FL 62240