

**EVALUATION REPORT OF
METAL SALES MANUFACTURING CORPORATION
'29 GA. PRO-PANEL II'**

**FLORIDA BUILDING CODE 7TH EDITION (2020)
FLORIDA PRODUCT APPROVAL
FL 14645.13-R4
ROOFING
METAL ROOFING**

**Prepared For:
Metal Sales Manufacturing Corporation
545 South 3rd Street, Suite 200
Louisville, KY 40202
Telephone: (502) 855-4300
Fax: (502) 855-4200**

**Prepared By:
Bala Sockalingam, Ph.D., P.E.
Florida Professional Engineer #62240
1216 N Lansing Ave., Suite C
Tulsa, OK 74106
Telephone: (918) 492-5992
FAX: (866) 366-1543**

**This report consists of
Evaluation Report (3 Pages including cover)
Installation Details (1 Page)**

**Report No. C2397-13
Date: 10.7.2020**

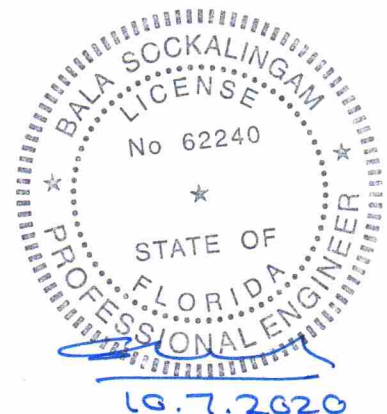

Manufacturer: Metal Sales Manufacturing Corporation

Product Name: Pro-Panel II

Panel Description: 36" wide coverage with (5) 5/8" high ribs

Materials: Min. 29 ga., 80 ksi steel or min. 26 ga., 50 ksi steel Galvanized coated steel (ASTM A653) or Galvalume coated steel (ASTM A792) or painted steel (ASTM A755). Corrosion resistant as per FBC 2020 Section 1507.4.3.

Deck Description: Min. 15/32" thick plywood or min. 3/4" thick wood plank (min SG of 0.42) for new and existing constructions. Designed by others and installed as per FBC 2020.

Deck Attachment: 8d x 2.5" long ring shank nails or #8 x 2" long wood screws @ 6" o.c. (Minimum) in the field and edges. Designed as per FBC 2020.

Underlayment: Minimum underlayment as per FBC 2020 Section 1507.4.5.1.

Substrate (optional): Min 1" x 4" No. 2 SYP wood purlins over min. 15/32" thick plywood deck fastened to supports at maximum 24" o.c. Wood purlins shall be fastened to wood rafters with (2) #9 x 3" long wood screws. The wood purlins will be spaced same as panel fastener spacing along panel length. The wood purlin, purlin to the rafter connection and rafters must be designed by others to carry the load imposed on the panels and installed as per FBC 2020.

Slope: 1/2:12 or greater in accordance with FBC 2020 Section 1507.4.2. Requires applied lap sealant for roof slopes less than 3:12.

Design Uplift Pressure: 41.6 psf @ fastener spacing of 24" o.c. (Factor of Safety = 2) 71.5 psf @ fastener spacing of 12" o.c.

Panel Attachment:
Type: #9-16 or #10-14 hex head wood screws with sealed washer. Fastener shall be of sufficient length to penetrate through the deck a minimum of 3/8". Fasteners are corrosion resistant as per FBC 2020 Section 1507.4.4.

At panel ends @ 6"-3"-6" o.c. across panel width
At intermediate @ 9" o.c. across panel width

Sidelap Attachment: 1/4"-14 x 7/8" long SDS with washer @ 12" o.c. Recommended for (Optional) roof slope less than 3:12. Fasteners are corrosion resistant as per FBC 2020 Section 1507.4.4.

- Test Standards: Roof assembly tested in accordance with TAS 125-03 'Standard Requirements for Metal Roofing Systems' and FM 4470 Section 5.5 'Resistance to Foot Traffic'.
- Test Equivalency: The test procedure in FM 4470 (1992) comply with test procedure prescribed in FM 4470 (2016) Section 4.6 'Resistance to Foot Traffic'.
- Code Compliance: The product described herein has demonstrated compliance with FBC 2020 Section 1507.4.
- Product Limitations: Design wind loads shall be determined for each project in accordance with FBC 2020 Section 1609 or ASCE 7-16 using allowable stress design. The maximum fastener spacing listed herein shall not be exceeded. This evaluation report is not applicable in High Velocity Hurricane Zone. Fire classification is not within scope of this Evaluation Report. Refer to FBC 2020 Section 1505 and current approved roofing materials directory or ASTM E108/UL790 report from an accredited laboratory for fire ratings of this product.
- Supporting Documents: TAS 125 Test Report
Farabaugh Engineering and Testing Inc.
Project No. T257-06, Reporting Date 11/14/06
- FM 4470 Test Report
ENCON Technology Inc.
C1587-3, Reporting Date 5/17/08

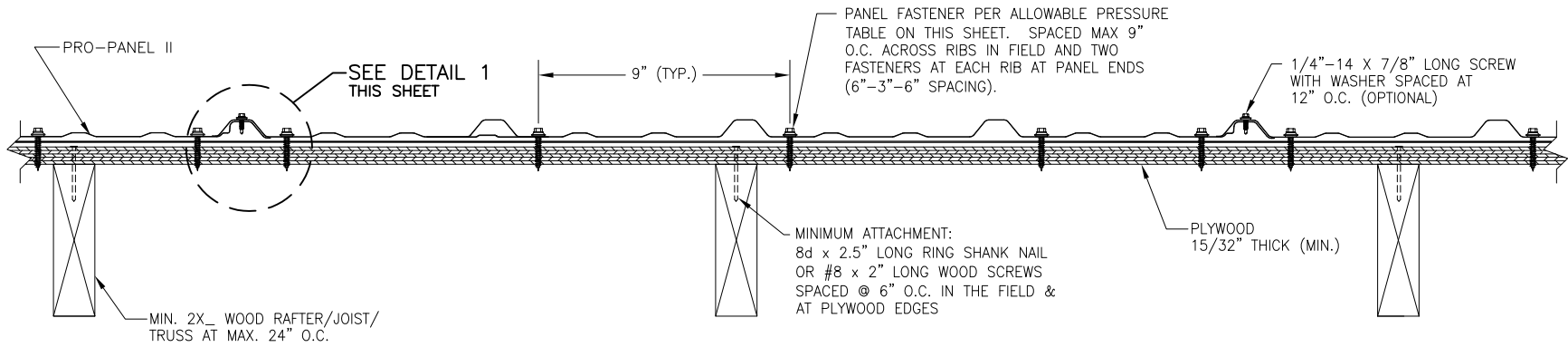

TYPICAL PANEL INSTALLATION X-SECTION

ALLOWABLE UPLIFT PRESSURE

| PANEL FASTENERS SPACING ALONG RIB | PRESSURE (PSF) |
|-----------------------------------|----------------|
| 24" | 41.6 |
| 12" | 71.5 |

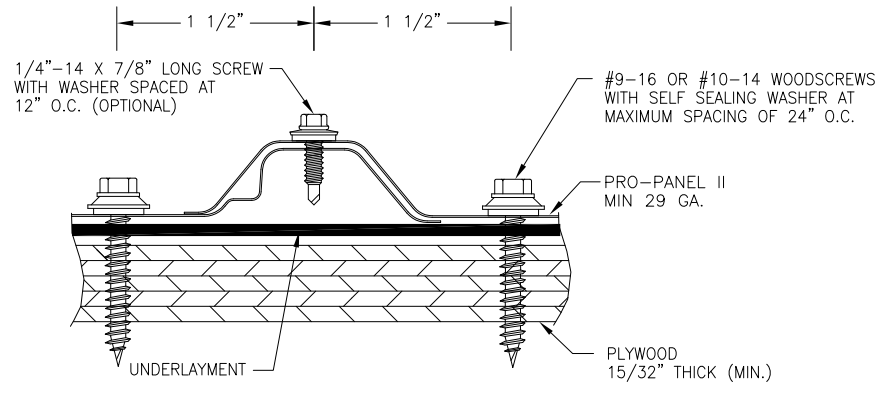

DETAIL 1

GENERAL NOTES:

1. ARCHITECTURAL ROOF PANEL HAS BEEN DESIGNED IN ACCORDANCE WITH THE FLORIDA BUILDING CODE (FBC).
2. ROOF PANELS SHALL BE MIN. 29 GA. (t = 0.0135"). EFFECTIVE COVERING WIDTH OF PANEL = 36".
3. THE ROOF PANELS SHALL BE INSTALLED OVER SHEATHING & STRUCTURE AS SPECIFIED ON THIS DRAWING.
4. REQUIRED DESIGN WIND LOADS SHALL BE DETERMINED FOR EACH PROJECT. THIS PANEL SYSTEM MAY NOT BE INSTALLED WHEN THE REQUIRED DESIGN WIND LOADS ARE GREATER THAN THE ALLOWABLE WIND LOADS SPECIFIED ON THIS DRAWING.
5. ALL FASTENERS MUST BE IN ACCORDANCE WITH THIS DRAWING & THE FLORIDA BUILDING CODE. IF A DIFFERENCE OCCURS BETWEEN THE MINIMUM REQUIREMENTS OF THIS DRAWING & THE CODE, THE CODE SHALL CONTROL.
6. RAFTERS/JOISTS/TRUSSES MUST BE DESIGNED TO WITHSTAND WIND LOADS AS REQUIRED FOR EACH APPLICATION AND ARE THE RESPONSIBILITY OF OTHERS.
7. REQUIRES APPLIED LAP SEALANT FOR ROOF SLOPE < 3:12.

| | |
|---|-------------------------------------|
| DRAWN BY: B.S. CHECKED BY: D.S. PLOT: DATE: 10/6/20 | NO. REVISION DESCRIPTION BY DATE |
| DRAWING TITLE: PRO-PANEL II | |
| CONSULTANTS: BALA SOOKALINGAM, PH.D., P.E. MANUFACTURER: METAL SALES MANUFACTURING CORP. 545 SOUTH 3RD ST., SUITE 200 LOUISVILLE, KY 40202 502-855-4300 | |
| 1216 N LANSING AVE, SUITE C TULSA, OK 74106 PHONE: 918-492-5992 FAX: 866-366-1543 | |
| DRAWING NO. 2397-13 PAGE NO. | REV. |
| 1 OF 1 | |