

# T2 WALL PANEL

Condensed  
Technical  
Reference

## Fontana, CA Profile

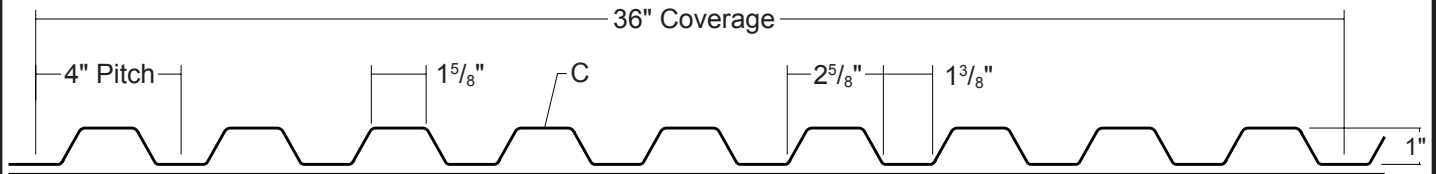

## Sellersburg, IN Profile

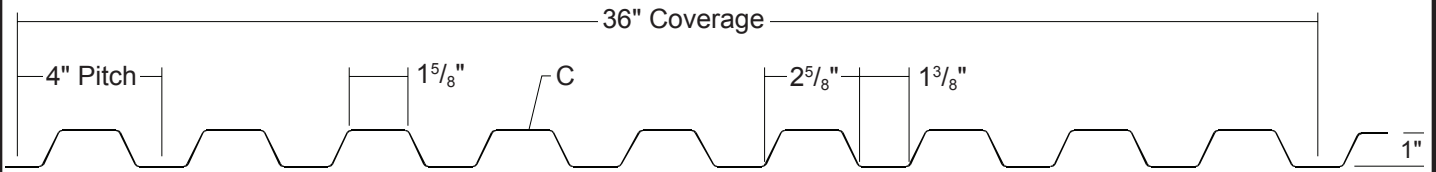

ARCHITECTURAL  
COMMERCIAL  
INDUSTRIAL  
PANEL

EXPOSED  
FASTENED

36"  
COVERAGE

WALL  
PANEL

OPEN FRAMING OR  
SOLID SUBSTRATE

## PANEL OVERVIEW

- ▶ Finishes: Standard: PVDF  
Optional: Multi-pass Kynar®, Marblique, Plastisol, Polyester and MS Colorfast45®
- ▶ Corrosion Protection: AZ55 per ASTM A 792 for unpainted Galvalume®  
AZ50 per ASTM A 792 for painted Galvalume®  
G90 per ASTM A 653 for Galvanized
- ▶ Gauges: 24 ga, 22 ga, 20 ga and 18 ga
- ▶ 36" panel coverage, 1" rib height
- ▶ Trapezoidal ribs on 4" centers
- ▶ Panel Length: 5' minimum, 31'-10" maximum
- ▶ Exposed Fastened Panel
- ▶ Optional material availability: Stainless Steel, Copper and Aluminum
- ▶ Custom capabilities include:
  - Perforated panels for wind screens and liner panels

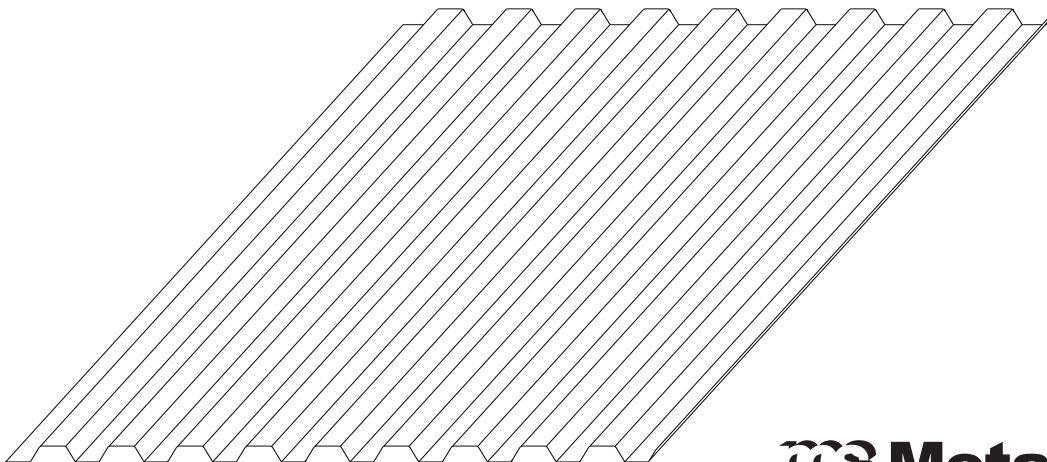

MS Metal Sales™

# T2 WALL PANEL

**Condensed  
Technical  
Reference**

## ATTACHMENT DETAIL

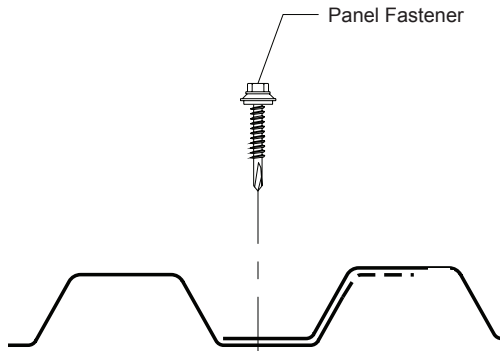

## FASTENING PATTERNS

### Ends of Panel

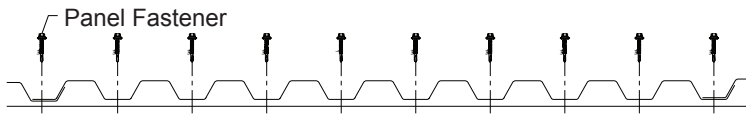

### Field of Panel

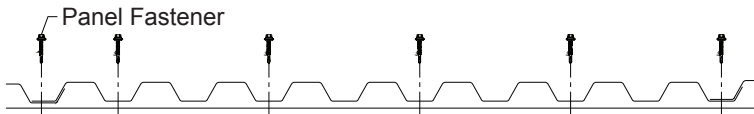

## FASTENER INFORMATION

Overdriven fasteners will cause panel distortion.

Panel fasteners should extend 1/2" or more past the inside face of the support material.

Thick panels (ex. 18 ga) or supports (ex. 1/2" steel) may require predrilling of holes for screws.

Panel Fastener:

Attaching to Wood:

#10-14 XL Wood Screw

Attaching to Steel:

#12-14 XL Self Drilling Screw

Trim Fastener:

1/8" x 3/16" Pop Rivet

1/4"-14 x 7/8" XL Stitch Screw

## SECTION PROPERTIES

## ALLOWABLE UNIFORM LOADS, psf For various fastener spacings

Ga	Width in	Yield ksi	Weight psf	Top in Compression		Bottom in Compression		Inward Load					Outward Load						
				I <sub>xx</sub> in <sup>4</sup> /ft	S <sub>xx</sub> in <sup>3</sup> /ft	I <sub>xx</sub> in <sup>4</sup> /ft	S <sub>xx</sub> in <sup>3</sup> /ft	4'	5'	6'	7'	8'	9'	4'	5'	6'	7'	8'	9'
24	36	50	1.21	0.0533	0.0960	0.0533	0.0956	138	80	46	29	20	14	138	80	46	29	20	14
22	36	50	1.59	0.0733	0.1392	0.0733	0.1380	198	107	62	39	26	18	200	107	62	39	26	18
20	36	33	1.94	0.0967	0.1877	0.0967	0.1823	172	111	75	47	32	22	177	114	75	47	32	22
18	36	33	2.55	0.1267	0.2427	0.1233	0.2377	224	145	98	62	41	29	229	148	98	62	41	29

- Theoretical section properties have been calculated per AISI 2016 'North American Specification for the Design of Cold-Formed Steel Structural Members'. I<sub>xx</sub> and S<sub>xx</sub> are effective section properties for deflection and bending.
- Allowable load is calculated in accordance with AISI 2016 specifications considering bending, shear, combined bending and shear and deflection. Allowable load considers the 3 or more equal spans condition. Allowable load does not address web crippling, fasteners, support material or load testing. Panel weight is not considered.
- Deflection consideration is limited by a maximum deflection ratio of L/180 of span.
- Allowable loads do not include a 1/3 stress increase for wind.

**MS Metal Sales™**

[metalsales.us.com](http://metalsales.us.com)

Anchorage, AK 866.640.7663  
Bay City, MI 888.777.7640  
Deer Lake, PA 800.544.2577  
Denver, CO 800.289.7663

Detroit Lakes, MN 888.594.1394  
Fontana, CA 800.782.7953  
Fort Smith, AR 877.452.3915  
Independence, MO 800.747.0012

Jacksonville, FL 800.394.4419  
Jefferson, OH 800.321.5833  
Mocksville, NC 800.228.6119  
Nashville, TN 800.251.8508  
Rock Island, IL 800.747.1206  
Rogers, MN 800.328.9316

Seattle, WA 800.431.3470  
Sellersburg, IN 800.999.7777  
Sioux Falls, SD 888.299.0024  
Spokane, WA 800.572.6565  
Temple, TX 800.543.4415  
Woodland, CA 800.759.6019