

T7-A ROOF PANEL

Condensed
Technical
Reference

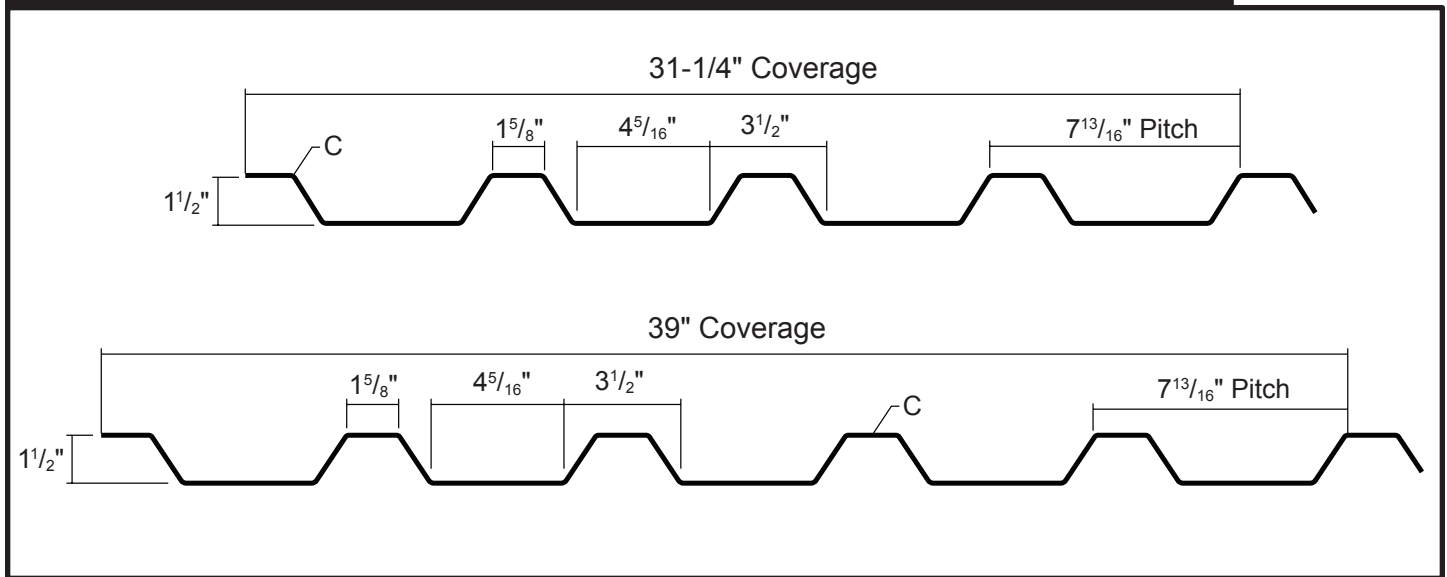

ARCHITECTURAL
COMMERCIAL
INDUSTRIAL
PANEL

EXPOSED
FASTENED

31 1/4" OR 39"
COVERAGE

MINIMUM
SLOPE
1:12

OPEN FRAMING OR
SOLID SUBSTRATE

PANEL OVERVIEW

- ▶ Finishes: Standard: PVDF
Optional: Multi-pass Kynar®, Marblique, Plastisol, Polyester and MS Colorfast45®
- ▶ Corrosion Protection: AZ55 per ASTM A 792 for unpainted Galvalume®
AZ50 per ASTM A 792 for painted Galvalume®
G90 per ASTM A 653 for Galvanized
- ▶ Gauges: 24 ga, 22 ga, 20 ga and 18 ga
- ▶ 31 1/4" or 39" panel coverage, 1 1/2" rib height
- ▶ Trapezoidal ribs on 7 13/16" centers
- ▶ Panel Length: 5' minimum, 31'-10" maximum
- ▶ Exposed Fastened Panel
- ▶ Minimum Roof Slope 1:12
- ▶ Optional material availability: Stainless Steel, Copper and Aluminum

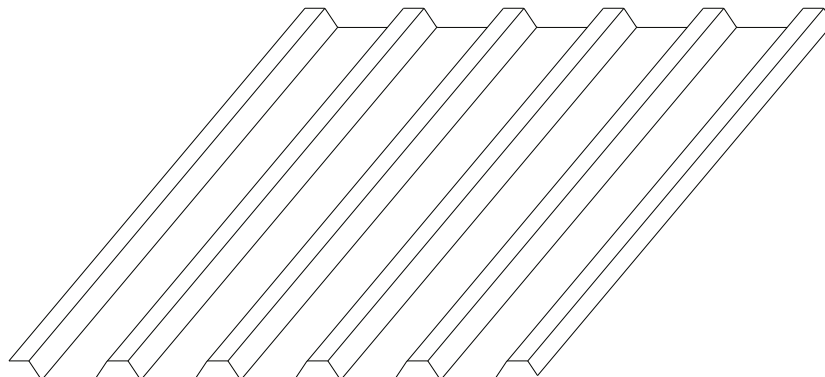

T7-A ROOF PANEL

**Condensed
Technical
Reference**

ATTACHMENT DETAIL

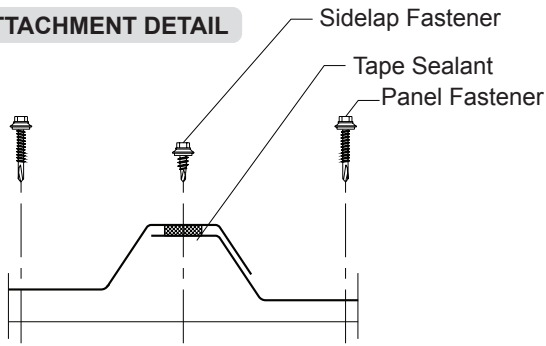

FASTENING PATTERNS

Ends of Panel

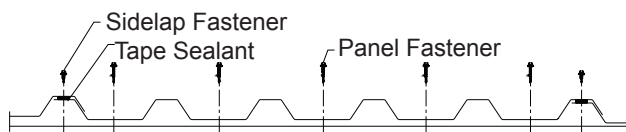

Field of Panel

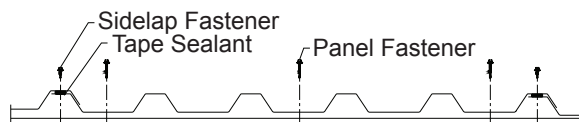

FASTENER INFORMATION

Overdriven fasteners will cause panel distortion.

Panel fasteners should extend 1/2" or more past the inside face of the support material.

Thick panels (ex. 18 ga) or supports (ex. 1/2" steel) may require predrilling of holes for screws.

Panel Fastener:

Attaching to Wood:

#10-14 XL Wood Screw

Attaching to Steel:

#12-14 XL Self Drilling Screw

Sidlap Fastener:

1/4"-14 x 7/8" XL Stitch Screw

Trim Fastener:

1/8" x 3/16" Pop Rivet

1/4"-14 x 7/8" XL Stitch Screw

SECTION PROPERTIES

ALLOWABLE UNIFORM LOADS, psf For various fastener spacings

Ga	Width in	Yield ksi	Weight psf	Top in Compression				Bottom in Compression				Inward Load						Outward Load					
				Ixx in ⁴ /ft		Sxx in ³ /ft		Ixx in ⁴ /ft		Sxx in ³ /ft		5'	6'	7'	8'	9'	10'	5'	6'	7'	8'	9'	10'
				in ⁴ /ft	in ³ /ft	in ⁴ /ft	in ³ /ft																
24	39	50	1.16	0.1046	0.1035	0.0794	0.0941	86	60	44	34	27	22	95	66	49	37	29	22				
22	39	50	1.52	0.1477	0.1488	0.1138	0.1392	128	89	66	51	39	28	137	95	70	54	39	28				
20	39	33	1.86	0.1969	0.2080	0.1569	0.2031	123	86	63	49	38	31	125	88	65	50	39	32				
18	39	33	2.45	0.2646	0.2775	0.2277	0.2748	166	116	85	66	52	42	167	117	86	66	52	43				

- Theoretical section properties have been calculated per AISI 2016 'North American Specification for the Design of Cold-Formed Steel Structural Members'. Ixx and Sxx are effective section properties for deflection and bending.
- Allowable load is calculated in accordance with AISI 2016 specifications considering bending, shear, combined bending and shear and deflection. Allowable load considers the 3 or more equal spans condition. Allowable load does not address web crippling, fasteners, support material or load testing. Panel weight is not considered.
- Deflection consideration is limited by a maximum deflection ratio of L/180 of span.
- Allowable loads do not include a 1/3 stress increase for wind.

MS Metal Sales™

metalsales.us.com

Anchorage, AK 866.640.7663
Bay City, MI 888.777.7640
Deer Lake, PA 800.544.2577
Denver, CO 800.289.7663

Detroit Lakes, MN 888.594.1394
Fontana, CA 800.782.7953
Fort Smith, AR 877.452.3915
Independence, MO 800.747.0012

Jacksonville, FL 800.394.4419
Jefferson, OH 800.321.5833
Mocksville, NC 800.228.6119
Nashville, TN 800.251.8508
Rock Island, IL 800.747.1206
Rogers, MN 800.328.9316

Seattle, WA 800.431.3470
Sellersburg, IN 800.999.7777
Sioux Falls, SD 888.299.0024
Spokane, WA 800.572.6565
Temple, TX 800.543.4415
Woodland, CA 800.759.6019