

MAGNA-LOC 90 - Aluminum

Condensed
Technical
Reference

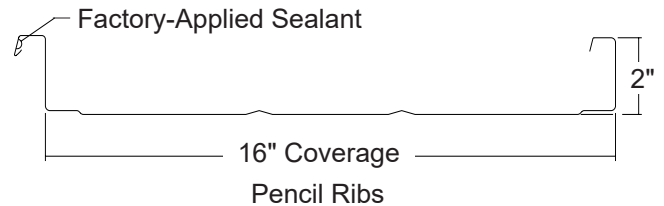
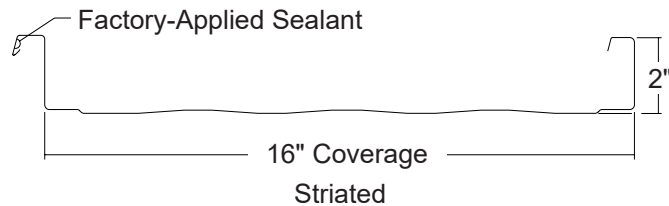
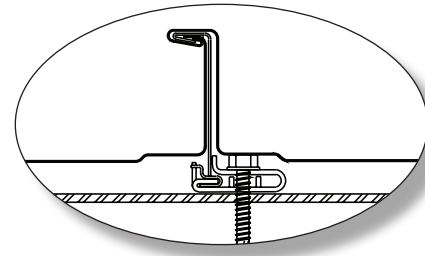
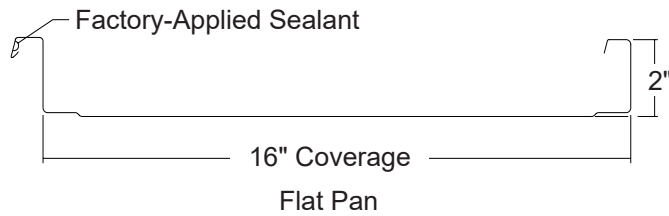

ARCHITECTURAL
COMMERCIAL
INDUSTRIAL
PANEL

CONCEALED
FASTENED

16"
COVERAGE

MINIMUM
1/2:12 SLOPE

OPEN FRAMING OR
SOLID SUBSTRATE

PANEL OVERVIEW

- ▶ Finish: PVDF
- ▶ Material: 3003-H14 Aluminum per ASTM B 209
- ▶ Thickness: 0.032"
- ▶ 16" panel coverage, 2" rib height
- ▶ Panels can be factory notched and punched for end laps
- ▶ Architectural/structural flat pan standing seam panel
- ▶ Applies over open framing or solid substrate
- ▶ Concealed clip designed to accommodate thermal movement, 1.5" each way
- ▶ Integral, mechanically seamed side lap
- ▶ Accommodates 1/2" to 6" blanket insulation
- ▶ Factory-applied side lap sealant
- ▶ Minimum roof slope: 1/2 :12

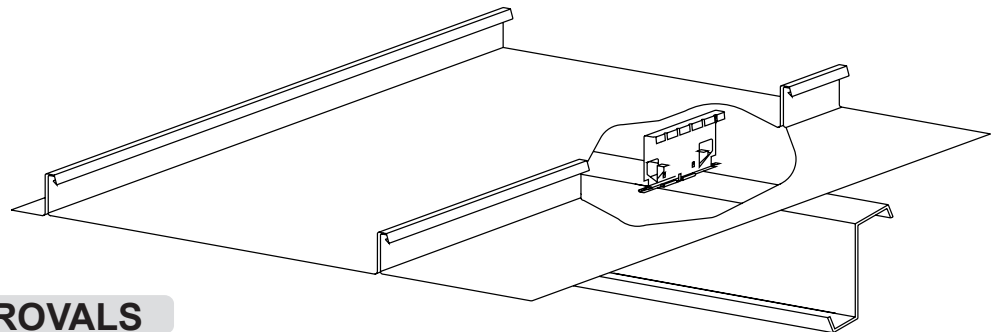

TESTING AND APPROVALS

- ▶ UL 2218, Class 4, Impact Resistance
- ▶ UL 790, Class A, Fire Resistance
- ▶ UL 263, Fire Resistance
- ▶ ASTM E 1680 Air Penetration - 0.0016 cfm/ft² leakage at 12 psf
- ▶ ASTM E 1646 Water Infiltration - No Leakage at 30 psf
- ▶ ASTM E 2140 Standing Water - No Leakage at 6" of water
- ▶ ASTM E 1592 Wind Uplift
- ▶ 2023 FBC Approval, FL10999.2

MS Metal Sales™

MAGNA-LOC 90 - Aluminum

**Condensed
Technical
Reference**

ATTACHMENT DETAILS

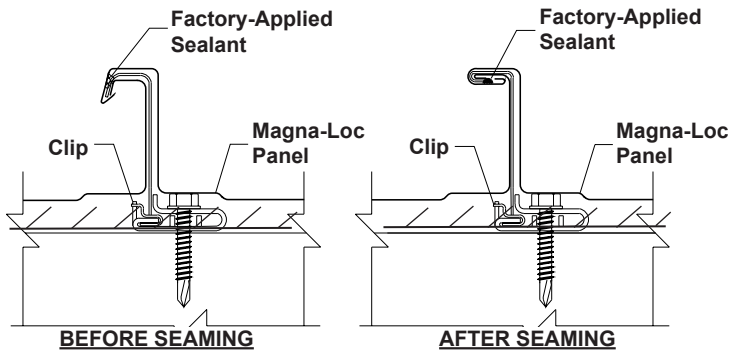

PANEL CLIP

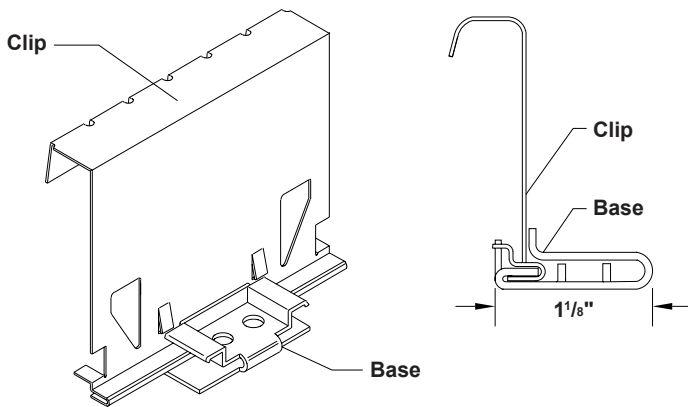

GENERAL INFORMATION

- ▶ **Length**
Minimum factory cut length is 5'-0" with striations and 7'-0" without striations.
Maximum recommended panel length is 45'-0".
Please inquire about longer panels.
- ▶ **Clips**
Clip spacing is based upon the spacing of structural framing members and loading requirements. Clips with Galvanized tabs are standard. Clips with Stainless Steel tabs are also available.
- ▶ **Fasteners**
Overdriven fasteners will cause panel distortions.

Panel and Clip fasteners should extend 1/2" or more past the inside face of the support material.

Type 304 Stainless Steel fasteners are recommended for applications exposed to corrosive environments.

Type of fastener material is shown in parenthesis.

Clip Fasteners:

Attaching to Wood:

#12-11 x 1.5" Wood Screw (Carbon Steel)

Attaching to Steel:

<18 ga: 1/4"-13 Deck Screw (Carbon Steel)

>= 18 ga, <= 12 ga: 1/4"-14 Driller (Carbon Steel)

> 12 ga: 1/4"-24 Driller, No Washer (Carbon Steel)

Exposed End Fasteners (Attaching to Eave Plate):

#12-14 Driller (Stainless Steel)

#12-14 Driller XL (Carbon Steel)

Concealed End Fasteners (Attaching to Eave Plate):

#12-14 Driller (Stainless Steel)

#12-14 Driller, No Washer (Carbon Steel)

Trim Fasteners:

1/8" x 3/16" Pop Rivets (Stainless Steel)

#14-11 x 1" Stitch Screw (Stainless Steel)

1/4"-14 x 7/8" Stitch Screw (Carbon Steel)

SECTION PROPERTIES

ALLOWABLE UNIFORM LOADS, psf for various clip spacings

Thick in	Width in	Yield ksi	Weight psf	I in ⁴ /ft	S _{Top} in ³ /ft	S _{Bottom} in ³ /ft	Z in ³ /ft	ALLOWABLE UNIFORM LOADS, psf for various clip spacings											
								Inward Load					Outward Load						
								1'	2'	2.5'	3'	4'	5'	1'	2'	2.5'	3'	4'	5'
0.032	16	17	0.60	0.2723	0.1568	0.6351	0.219	210	105	84	49	20	10	87	73	60	50	37	30

- Theoretical section properties have been calculated per 2015 Aluminum Design Manual. I, S and Z are section properties for deflection and bending.
- Allowable load is calculated in accordance with 2015 Aluminum Design Manual specifications considering bending, shear, combined bending & shear, deflection and uplift testing per ASTM E 1592. Allowable load does not consider other support conditions such as web crippling, fasteners or support material. Panel weight is not considered.
- Allowable load considers the three or more equal span case.
- Deflection consideration is limited by a maximum deflection ratio of L/180 of span.
- Allowable loads do not include a 1/3 stress increase in uplift.

MS Metal Sales™

metalsales.us.com

Anchorage, AK 866.640.7663
Bay City, MI 888.777.7640
Deer Lake, PA 800.544.2577
Denver, CO 800.289.7663

Detroit Lakes, MN 888.594.1394
Fontana, CA 800.782.7953
Fort Smith, AR 877.452.3915
Independence, MO 800.747.0012

Jacksonville, FL 800.394.4419
Jefferson, OH 800.321.5833
Mocksville, NC 800.228.6119
Nashville, TN 800.251.8508
Rock Island, IL 800.747.1206
Rogers, MN 800.328.9316

Seattle, WA 800.431.3470
Sellersburg, IN 800.999.7777
Sioux Falls, SD 888.299.0024
Spokane, WA 800.572.6565
Temple, TX 800.543.4415
Woodland, CA 800.759.6019