

TLC-12 WALL PANEL

Condensed
Technical
Reference

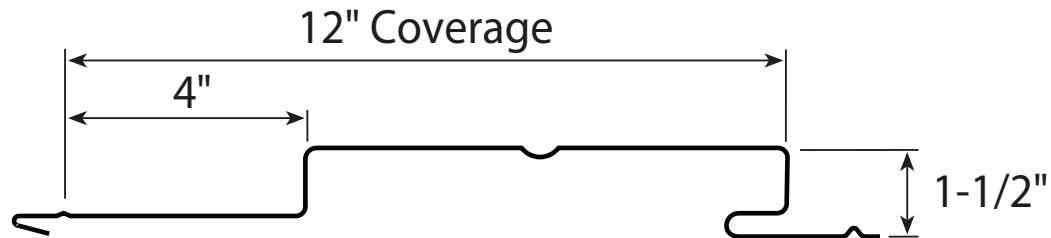

ARCHITECTURAL
COMMERCIAL
INDUSTRIAL
PANEL

CONCEALED
FASTENED

12"
COVERAGE

SOFFIT, FASCIA,
WALL AND LINER
PANEL

OPEN FRAMING OR
SOLID SUBSTRATE

PANEL OVERVIEW

- ▶ Finish: Standard: PVDF
Optional: multi-pass PVDF
- ▶ Corrosion Protection: AZ50 per ASTM A 792 for painted Galvalume®
G90 per ASTM A 653 for Galvanized
- ▶ Gauges: 24 ga, 22 ga and 20 ga
- ▶ 12" panel coverage, 1 1/2" panel height
- ▶ Flush face with 4" reveal, concealed fastened, non-end lapping panel system
- ▶ Roll-Formed Panels
- ▶ Panel Length: 5' minimum, 40' maximum
- ▶ Use on single-skin or field-assembled wall systems
- ▶ Panels can be installed horizontally or vertically and are interchangeable for accent effects
- ▶ Custom capabilities include:
 - Perforated panels for wind screens and liner panels

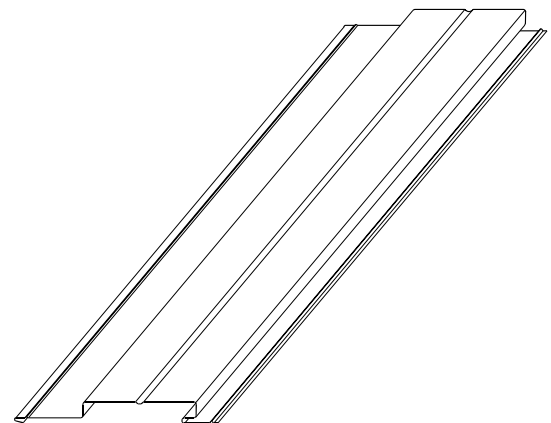

TESTING AND APPROVALS

- ▶ ASTM E 283 Air Leakage
- ▶ ASTM E 331 Water Penetration
- ▶ ASTM E 330 Uniform Static Air Pressure Difference
- ▶ ASTM E 1592 Load Test

Metal Sales™

TLC-12 WALL PANEL

**Condensed
Technical
Reference**

FASTENING PATTERN

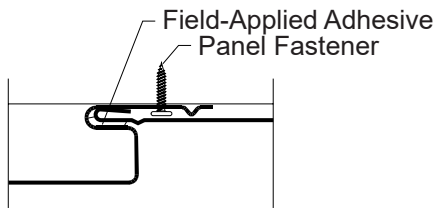
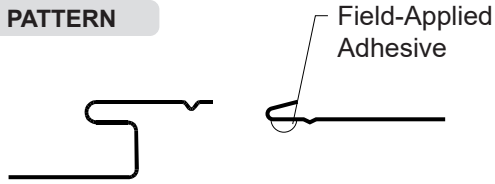

DIRECTIONAL DETAILS

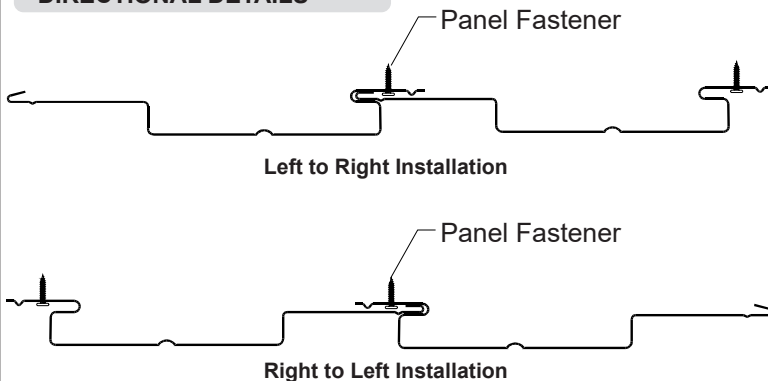

FASTENING INFORMATION

Overdriven fasteners will cause panel distortions.

Fasteners should extend 1/2" or more past the inside face of the support material.

Thick Panels (ex. 20 ga) or supports (ex. 1/2" steel) may require predrilling of holes for screws.

Panel Fasteners:

Attaching to Wood:

#10-12 Pancake Head Wood Screw

Attaching to Steel:

<18 ga: 1/4"-13 Deck Screw

>=18 ga, <=12 ga: #10-16 Pancake Head Drill

Trim Fasteners:

1/4"-14 x 7/8" XL Stitch Screw

1/8" x 3/16" Pop Rivet

Field-Applied Adhesive:

1/4" diameter bead of Geocel 4600

Vertical panels may be installed left-to-right or right-to-left.

Horizontal panels are installed from top to bottom.

SECTION PROPERTIES

Ga	Width in	Yield ksi	Weight psf	Top In Compression		Bottom In Compression	
				Ixx in ⁴ /ft	Sxx in ³ /ft	Ixx in ⁴ /ft	Sxx in ³ /ft
				24	12	50	1.50
22	12	50	1.96	0.0890	0.0880	0.1590	0.1538
20	12	33	2.38	0.1260	0.1291	0.2140	0.2144

ALLOWABLE UNIFORM LOADS, psf For various fastener spacings

Inward Load						Outward Load					
2'	3'	4'	5'	6'	8'	2'	3'	4'	5'	6'	8'
50	33	25	20	19	18	80	53	40	32	27	25
63	42	31	29	27	25	88	58	44	35	32	30
63	42	31	29	27	25	88	58	44	35	32	30

- Theoretical section properties have been calculated per AISI S100-2016 'North American Specification for the Design of Cold-Formed Steel Structural Members'. Ixx and Sxx are effective section properties for deflection and bending.
- Allowable load is calculated in accordance with AISI 2016 specifications considering bending, shear, combined bending & shear, deflection and ASTM E 330 testing on 16 ga girts. Allowable load considers the 3 or more equal spans condition. Allowable load does not address web crippling, fasteners, support material or load testing with other supports. Panel weight is not considered.
- Deflection consideration is limited by a maximum deflection ratio of L/180 of span.
- Allowable loads do not include a 1/3 stress increase for wind.

MS Metal Sales

metalsales.us.com

Anchorage, AK 866.640.7663
Bay City, MI 888.777.7640
Deer Lake, PA 800.544.2577
Denver, CO 800.289.7663

Detroit Lakes, MN 888.594.1394
Fontana, CA 800.782.7953
Fort Smith, AR 877.452.3915
Independence, MO 800.747.0012

Jacksonville, FL 800.394.4419
Jefferson, OH 800.321.5833
Kelso, WA 800.431.3470
Mocksville, NC 800.228.6119
Nashville, TN 800.251.8508
Rock Island, IL 800.747.1206

Rogers, MN 800.328.9316
Sellersburg, IN 800.999.7777
Sioux Falls, SD 888.299.0024
Spokane, WA 800.572.6565
Temple, TX 800.543.4415
Woodland, CA 800.759.6019

©MSMC/3-2024