



Installation Guide
T-Armor Series™

metalsales.us.com

The application and detail drawings in this manual are strictly for illustration purposes and may not be applicable to all building designs or product installations. All projects should conform to applicable building codes for that particular area. It is recommended to follow all building regulations and standard industry practices.

Metal Sales Manufacturing Corporation is not responsible for the performance of the roof system if it is not installed in accordance with the suggested instructions referenced in this manual. If there is a conflict between this manual and the approved Metal Sales' erection drawings, the approved erection drawings are to take precedence.

Prior to ordering and installing materials, all dimensions should be verified by field measurements.

Oil canning is not a cause for rejection. Oil canning can be described as the amount of waviness found in the flat areas of metal panels. Oil canning is an inherent characteristic of light gauge cold formed metal products, particularly those with broad flat areas. There are many factors which may contribute to oil canning that Metal Sales is not able to control. These factors include: misalignment of the support system, over driving of fasteners used on the panels, stress (whether inherent in the panel or induced), thermal expansion and contraction of the panel, material handling, width, gauge, length, color of panels and installation. (reference Metal Construction Association "Oil Canning Position Paper" - Appendix A).

Metal Sales reserves the right to modify, without notice, any details, recommendations or suggestions. Any questions you may have regarding proper installation of the T-Armor Series™ roofing system should be directed to your Metal Sales representative (see pages 2 and 3).

Consult Metal Sales for any additional information not addressed in this manual.

This manual is designed to be utilized as a guide when installing T-Armor roofing system. It is the responsibility of the erector to ensure the safe installation of this product system.

SAFETY

STUDY APPLICABLE OSHA AND OTHER SAFETY REQUIREMENTS BEFORE FOLLOWING THESE INSTRUCTIONS.

The installation of metal roof systems is a dangerous undertaking and should be supervised by trained, knowledgeable erectors. **USE EXTREME CARE WHILE INSTALLING ROOF PANELS.** It is not possible for Metal Sales to be aware of all the possible job site situations that could cause an unsafe condition to exist. The erector of the roof system is responsible for reading these instructions and determining the safest way to install the roof system.

These instructions are provided only as a guide to show a knowledgeable, trained erector the correct parts placement one to another. If following any of the installation steps would endanger a worker, the erector should stop work and decide upon a corrective action.

Provide required safety railing, netting or safety lines for crew members working on the roof.

Do not use the roof panel as a walking platform. The roof panels will not withstand the weight of a person standing at the edge of the panel.

Do not stand on any part of a roof panel until the panel has been completely attached.

ms Metal Sales™

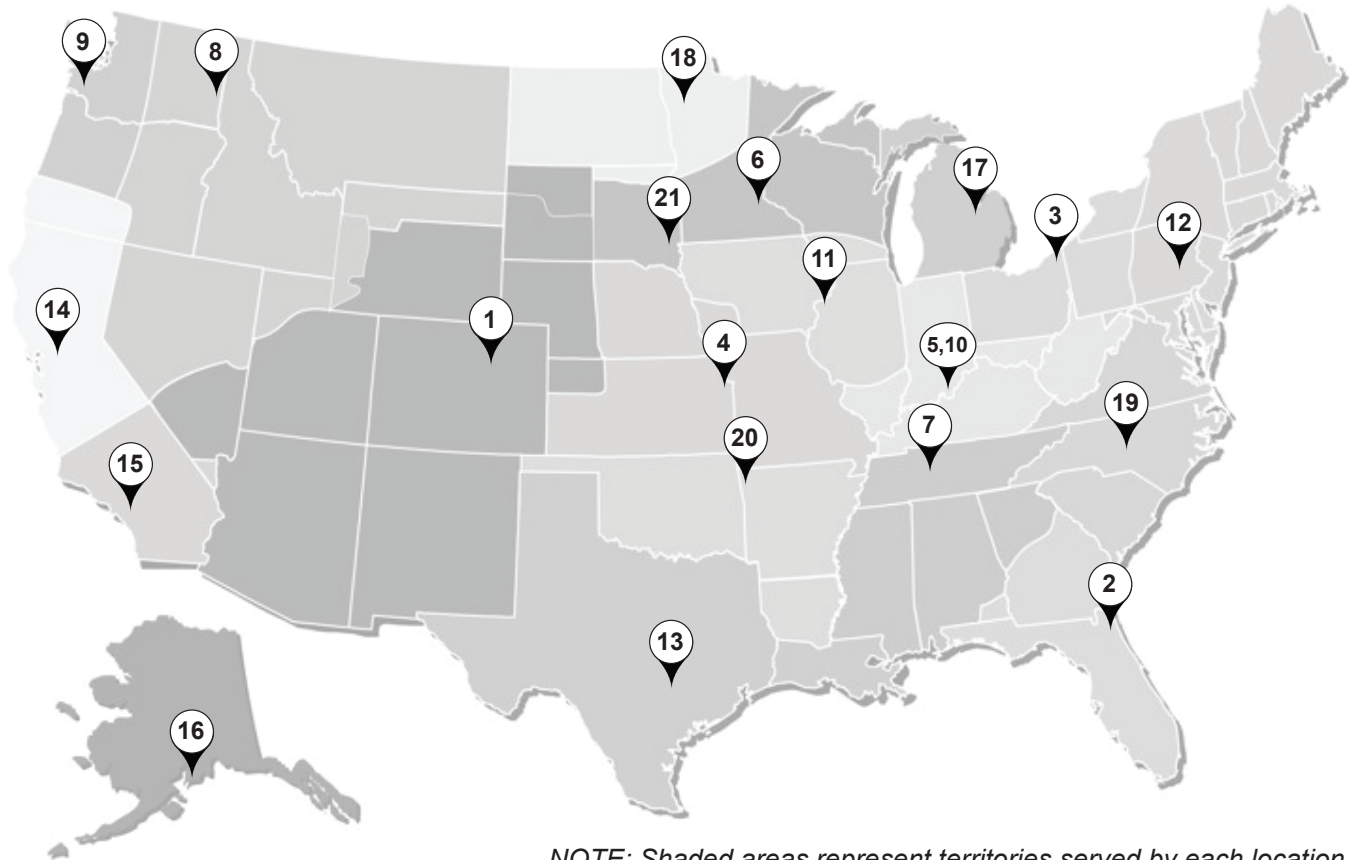

NOTE: Shaded areas represent territories served by each location.



T-Armor panels are manufactured at our Sellersburg, IN branch.
They can be ordered and shipped nationwide.

1. DENVER

7990 East I-25 Frontage Road
 Longmont, CO 80504
 303.702.5440
 800.289.7663
 800.289.1617 Fax

2. JACKSONVILLE

7110 Stuart Avenue
 Jacksonville, FL 32254
 904.783.3660
 800.394.4419
 904.783.9175 Fax
 800.413.3292 Fax

3. JEFFERSON

352 East Erie Street
 Jefferson, OH 44047
 440.576.9070
 800.321.5833
 440.576.9242 Fax
 800.233.5719 Fax

4. INDEPENDENCE

1306 South Powell Road
 Independence, MO 64057
 816.796.0900
 800.747.0012
 816.796.0906 Fax

5. SELLERSBURG

7800 Highway 60
 Sellersburg, IN 47172
 812.246.1866
 800.999.7777
 812.246.0893 Fax
 800.477.9318 Fax

6. ROGERS

22651 Industrial Boulevard
 Rogers, MN 55374
 763.428.8080
 800.328.9316
 763.428.8525 Fax
 800.938.9119 Fax

7. NASHVILLE

4314 Hurricane Creek Boulevard
 Antioch, TN 37013
 615.641.7100
 800.251.8508
 615.641.7118 Fax
 800.419.4372 Fax

8. SPOKANE

2727 East Trent Avenue
 Spokane, WA 99202
 509.536.6000
 800.572.6565
 509.534.4427 Fax

9. KELSO

2680 Coweeman Park Drive
 Kelso, WA 98626
 253.872.5750
 800.431.3470
 253.872.2008 Fax

10. NEW ALBANY

999 Park Place
 New Albany, IN 47150
 812.944.2733
 812.944.1418 Fax

11. ROCK ISLAND

8111 West 29th Street
 Rock Island, IL 61201
 309.787.1200
 800.747.1206
 309.787.1833 Fax

12. DEER LAKE

29 Pinedale Industrial Road
 Orwigsburg, PA 17961
 570.366.2020
 800.544.2577
 570.366.1648 Fax
 800.544.2574 Fax

13. TEMPLE

3838 North General Bruce Drive
 Temple, TX 76501
 254.791.6650
 800.543.4415
 254.791.6655 Fax
 800.543.4473 Fax

14. WOODLAND

1326 Paddock Place
 Woodland, CA 95776
 530.668.5690
 800.759.6019
 530.668.0901 Fax

15. FONTANA

14213 Whittram Avenue
 Fontana, CA 92335
 909.829.8618
 800.782.7953
 909.829.9083 Fax

16. ANCHORAGE

4637 Old Seward Highway
 Anchorage, AK 99503
 907.646.7663
 866.640.7663
 907.646.7664 Fax

17. BAY CITY

5209 Mackinaw Road
 Bay City, MI 48706
 989.686.5879
 888.777.7640
 989.686.5870 Fax
 888.777.0112 Fax

18. DETROIT LAKES

1435 Egret Avenue
 Detroit Lakes, MN 56501
 218.847.2988
 888.594.1394
 218.847.4835 Fax
 888.594.1454 Fax

19. MOCKSVILLE

188 Quality Drive
 Mocksville, NC 27028
 336.751.6381
 800.228.6119
 336.751.6301 Fax
 800.228.7916 Fax

20. FORT SMITH

7510 Ball Road
 Fort Smith, AR 72908
 479.646.1176
 877.452.3915
 479.646.5204 Fax

21. SIOUX FALLS

2700 West 3rd Street, Suite 4
 Sioux Falls, SD 57104
 605.335.2745
 888.299.0024

CORPORATE OFFICE

7800 Highway 60
 Sellersburg, IN 47172
 800.406.7387
 800.944.6884 Fax

TECHNICAL SUPPORT**TECH SERVICES DEPT.**

7800 Highway 60
 Sellersburg, IN 47172
 502.855.4300
 800.406.7387
 800.944.6884 Fax

SECTION	PAGE NO.
General Information	
Important Information	1
Metal Sales Locations	2
Branch Locations	3
Table of Contents	4 & 5
Flashing Angle Chart	6
Panel Profiles	
Flat Panel Profile.....	7
Pencil Rib Panel Profile.....	8
Minor Rib Panel Profile	9
Striated Panel Profile	10
Mesa Panel Profile.....	11
Plank Panel Profile.....	12
Accessory Profiles	13-16
Flashing Profiles	17-23
Fastener Selection Guide.....	24
Fastener Technical Information	
Physical Properties	25
Pull Out Strength Values.....	26
Pull Over Strength Values.....	27
Testing Information	
UL 580 Wind Uplift Information	28-30
UL 263 Fire Resistance Rating	31
Testing Summary	31
Section Properties and Load Tables	
2 ³ / ₈ " Steel Panel Properties.....	32
2 ³ / ₈ " Aluminum Panel Properties	33
3" Steel Panel Properties	34
3" Aluminum Panel Properties	35
Handling Material	
Receiving Material	36
General Handling	36
Mechanical Handling	36
Manual Handling	37
Storage	
General	38
Storage on Roof	39
Installation Concerns	39
Foot Traffic	40
Curb Installation	40
Field Cutting and Touch-up	
Field Cutting	41
Touch-up Paint	41
Design / Installation Considerations	
Fastener Installation Technique	42
Condition of Substructure	42
Ventilation	43
Insulation	43
System Expansion / Contraction	44
Selection of System Components	44
Panel and Cap Notching	45
Installation Strategies/Directions	46
Installation of Panel	
Installation of Eave Flashing	47
Installation of Rake Angle	48
Installing First Panel	49
Installing Panel Clips.....	50
Endlapping of Panel.....	48-51

SECTION	PAGE NO.
Sidelapping of Panel	53
Termination of Panel	54
Seaming Panels	55-56
Panel Removal and Replacement.....	56
Installation Details	
Post Hung Gutter - Floating	57
Box Gutter - Floating	58
Eave Transition - Knee Cap	59
Eave - Floating	60
Valley - Floating.....	61
Endlap	62
Rake	63
Rakewall.....	64
Expansion Joint	65
Endwall - Fixed.....	66
Peak - Fixed	67
Ridge/Hip - Fixed	68
Post Hung Gutter - Fixed	69
Box Gutter -Fixed.....	70
Eave - Fixed.....	71
Drop Valley - Fixed.....	72
Endwall - Floating.....	73
Ridge/Hip - Floating	74
Z-Closure Installation.....	75
Hemming/Turn-Up Detail	76
Miscellaneous Details	77
Roof Penetrations	77
Installation Notes.....	77
Flashing Laps.....	77
Care and Maintenance	78
Panel Replacement	79
Notes 80.....	80

This chart should be used to determine the specified angle.

PROFILE/FLASHING	1/4:12	1/2:12	1:12	2:12	3:12	4:12	5:12	6:12	7:12	8:12
RIDGE SSR RIDGE VENTED RIDGE COVER	178°	175°	170°	161°	152°	143°	*135°	*127°	*120°	*113°
HIP VALLEY	178°	177°	173°	167°	160°	154°	148°	143°	138°	134°
EAVE, ROOF CLEAT SCULPTURED EAVE	91°	92°	95°	99°	104°	108°	113°	117°	120°	124°
SSR SCULPTURED HIGH SIDE EAVE	99°	98°	95°	91°	86°	82°	*77°	*73°	*70°	*66°
PEAK, ROOF CLEAT	89°	88°	85°	81°	76°	72°	67°	63°	60°	56°
PITCH BREAK	91°	92°	95°	99°	104°	108°	113°	117°	120°	124°
GUTTER DRIP BOX GUTTER	91°	92°	95°	99°	104°	108°	113°	117°	120°	124°

T-ARMOR PEAK "A" DIMENSION

2 ³ / ₈ " UTILITY SYSTEM	5 ¹ / ₂ "	5 ¹ / ₂ "	5 ¹ / ₂ "	5 ⁵ / ₈ "	5 ⁵ / ₈ "	5 ³ / ₄ "	6"	6 ¹ / ₈ "	6 ³ / ₈ "	6 ⁵ / ₈ "
2 ³ / ₈ " LOW SYSTEM	5 ⁷ / ₈ "	5 ⁷ / ₈ "	5 ⁷ / ₈ "	6"	6"	6 ¹ / ₈ "	6 ³ / ₈ "	6 ¹ / ₂ "	6 ⁷ / ₈ "	7 ¹ / ₈ "
2 ³ / ₈ " HIGH SYSTEM	6 ⁷ / ₈ "	6 ⁷ / ₈ "	6 ⁷ / ₈ "	7"	7 ¹ / ₈ "	7 ¹ / ₄ "	7 ¹ / ₂ "	7 ⁵ / ₈ "	8"	8 ¹ / ₄ "
3" UTILITY SYSTEM	6 ¹ / ₈ "	6 ¹ / ₈ "	6 ¹ / ₈ "	6 ¹ / ₄ "	6 ¹ / ₄ "	6 ¹ / ₂ "	6 ⁵ / ₈ "	6 ⁷ / ₈ "	7 ¹ / ₈ "	7 ³ / ₈ "
3" LOW SYSTEM	6 ¹ / ₂ "	6 ¹ / ₂ "	6 ¹ / ₂ "	6 ⁵ / ₈ "	6 ³ / ₄ "	6 ⁷ / ₈ "	7"	7 ¹ / ₄ "	7 ¹ / ₂ "	7 ³ / ₄ "
3" HIGH SYSTEM	7 ¹ / ₂ "	7 ¹ / ₂ "	7 ¹ / ₂ "	7 ⁵ / ₈ "	7 ³ / ₄ "	7 ⁷ / ₈ "	8 ¹ / ₈ "	8 ³ / ₈ "	8 ⁵ / ₈ "	9"

T-ARMOR EAVE "A" DIMENSION

FLOATING SYSTEM	3"	3"	3"	3"	3 ¹ / ₈ "	3 ¹ / ₈ "	3 ¹ / ₄ "	3 ³ / ₈ "	3 ¹ / ₂ "	3 ⁵ / ₈ "
FIXED UTILITY SYSTEM	3 ¹ / ₄ "	3 ¹ / ₄ "	3 ¹ / ₄ "	3 ¹ / ₄ "	3 ³ / ₈ "	3 ³ / ₈ "	3 ¹ / ₂ "	3 ⁵ / ₈ "	3 ³ / ₄ "	3 ⁷ / ₈ "
FIXED LOW SYSTEM	3 ³ / ₈ "	3 ³ / ₈ "	3 ³ / ₈ "	3 ³ / ₈ "	3 ¹ / ₂ "	3 ¹ / ₂ "	3 ⁵ / ₈ "	3 ³ / ₄ "	3 ⁷ / ₈ "	4"
FIXED HIGH SYSTEM	4 ³ / ₈ "	4 ³ / ₈ "	4 ³ / ₈ "	4 ³ / ₈ "	4 ¹ / ₂ "	4 ⁵ / ₈ "	4 ³ / ₄ "	4 ⁷ / ₈ "	5 ¹ / ₈ "	5 ¹ / ₄ "

ROOF CLEAT "A" DIMENSION

All SYSTEMS	3"	3"	3"	3"	3 ¹ / ₈ "	3 ¹ / ₈ "	3 ¹ / ₄ "	3 ³ / ₈ "	3 ¹ / ₂ "	3 ⁵ / ₈ "
-------------	----	----	----	----	---------------------------------	---------------------------------	---------------------------------	---------------------------------	---------------------------------	---------------------------------

Note: "A" Dimension is 3" for Roof Cleat at Rake conditions for all slopes.

*Note: Metal Sales standard flashing dimensions may not accommodate all situations, please inquire about custom flashings for slopes 5:12 or greater.

FLAT PANEL • 12" COVERAGE



GAUGES	2 3/8" RIB HEIGHT			WEIGHT PER SQ.	GAUGES	3" RIB HEIGHT			WEIGHT PER SQ.
	ACG	PVDF	BARE ALUM.			ACG	PVDF	BARE ALUM.	
24 GA	TA10141	TA101XX	-	172 lbs	24 GA	TA10541	TA105XX	-	182 lbs
22 GA	TA20141	TA201XX	-	218 lbs	22 GA	TA20541	TA205XX	-	231 lbs
.032 AL	-	TA101XXA	TA10101A	86 lbs	.032 AL	-	TA105XXA	TA10501A	90 lbs

FLAT PANEL • 16" COVERAGE

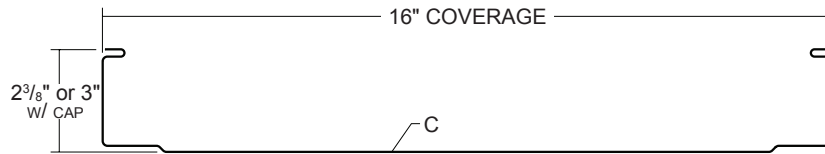

GAUGES	2 3/8" RIB HEIGHT			WEIGHT PER SQ.	GAUGES	3" RIB HEIGHT			WEIGHT PER SQ.
	ACG	PVDF	BARE ALUM.			ACG	PVDF	BARE ALUM.	
24 GA	TA10241	TA102XX	-	152 lbs	24 GA	TA10641	TA106XX	-	160 lbs
22 GA	TA20241	TA202XX	-	194 lbs	22 GA	TA20641	TA206XX	-	203 lbs
.032 AL	-	TA102XXA	TA10201A	75 lbs	.032 AL	-	TA106XXA	TA10601A	79 lbs

FLAT PANEL • 18" COVERAGE

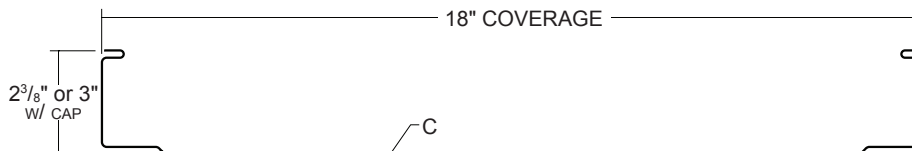

GAUGES	2 3/8" RIB HEIGHT			WEIGHT PER SQ.	GAUGES	3" RIB HEIGHT			WEIGHT PER SQ.
	ACG	PVDF	BARE ALUM.			ACG	PVDF	BARE ALUM.	
24 GA	TA10341	TA103XX	-	146 lbs	24 GA	TA10741	TA107XX	-	152 lbs
22 GA	TA20341	TA203XX	-	186 lbs	22 GA	TA20741	TA207XX	-	194 lbs
.032 AL	-	TA103XXA	TA10301A	72 lbs	.032 AL	-	TA107XXA	TA10701A	75 lbs

Panel weight includes the panel cap and panel clips at a 48" spacing.

PENCIL RIB PANEL • 12" COVERAGE

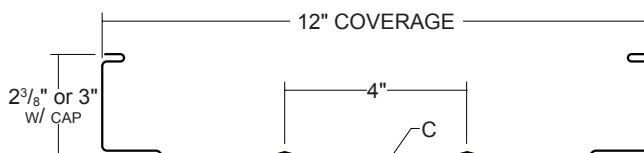

2 ³ / ₈ " RIB HEIGHT				WEIGHT PER SQ.	3" RIB HEIGHT				WEIGHT PER SQ.
GAUGES	ACG	PVDF	BARE ALUM.		GAUGES	ACG	PVDF	BARE ALUM.	
24 GA	TA11141	TA111XX	-	172 lbs	24 GA	TA11541	TA115XX	-	182 lbs
22 GA	TA21141	TA211XX	-	218 lbs	22 GA	TA21541	TA215XX	-	231 lbs
.032 AL	-	TA111XXA	TA11101A	86 lbs	.032 AL	-	TA115XXA	TA11501A	90 lbs

PENCIL RIB PANEL • 16" COVERAGE

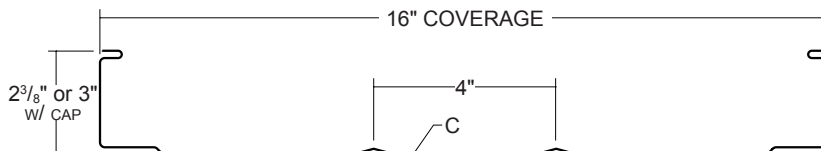

2 ³ / ₈ " RIB HEIGHT				WEIGHT PER SQ.	3" RIB HEIGHT				WEIGHT PER SQ.
GAUGES	ACG	PVDF	BARE ALUM.		GAUGES	ACG	PVDF	BARE ALUM.	
24 GA	TA11241	TA112XX	-	152 lbs	24 GA	TA11641	TA116XX	-	160 lbs
22 GA	TA21241	TA212XX	-	194 lbs	22 GA	TA21641	TA216XX	-	203 lbs
.032 AL	-	TA112XXA	TA11201A	75 lbs	.032 AL	-	TA116XXA	TA11601A	79 lbs

PENCIL RIB PANEL • 18" COVERAGE

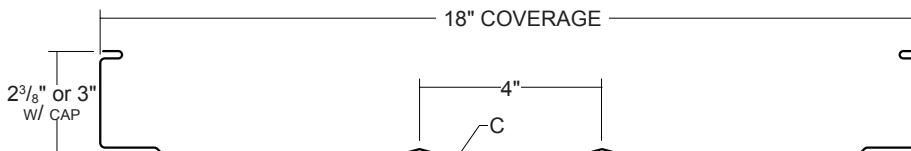

2 ³ / ₈ " RIB HEIGHT				WEIGHT PER SQ.	3" RIB HEIGHT				WEIGHT PER SQ.
GAUGES	ACG	PVDF	BARE ALUM.		GAUGES	ACG	PVDF	BARE ALUM.	
24 GA	TA11341	TA113XX	-	146 lbs	24 GA	TA11741	TA117XX	-	152 lbs
22 GA	TA21341	TA213XX	-	186 lbs	22 GA	TA21741	TA217XX	-	194 lbs
.032 AL	-	TA113XXA	TA11301A	72 lbs	.032 AL	-	TA117XXA	TA11701A	75 lbs

Panel weight includes the panel cap and panel clips at a 48" spacing.

MINOR RIB PANEL • 12" COVERAGE

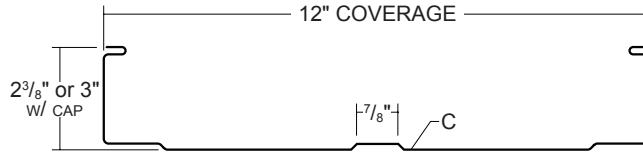

GAUGES	2 3/8" RIB HEIGHT			WEIGHT PER SQ.	GAUGES	3" RIB HEIGHT			WEIGHT PER SQ.
	ACG	PVDF	BARE ALUM.			ACG	PVDF	BARE ALUM.	
24 GA	TA12141	TA121XX	-	172 lbs	24 GA	TA12541	TA125XX	-	182 lbs
22 GA	TA22141	TA221XX	-	218 lbs	22 GA	TA22541	TA225XX	-	231 lbs
.032 AL	-	TA121XXA	TA12101A	86 lbs	.032 AL	-	TA125XXA	TA12501A	90 lbs

MINOR RIB PANEL • 16" COVERAGE

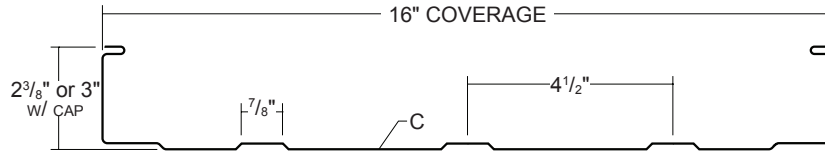

GAUGES	2 3/8" RIB HEIGHT			WEIGHT PER SQ.	GAUGES	3" RIB HEIGHT			WEIGHT PER SQ.
	ACG	PVDF	BARE ALUM.			ACG	PVDF	BARE ALUM.	
24 GA	TA12241	TA122XX	-	152 lbs	24 GA	TA12641	TA126XX	-	160 lbs
22 GA	TA22241	TA222XX	-	194 lbs	22 GA	TA22641	TA226XX	-	203 lbs
.032 AL	-	TA122XXA	TA12201A	75 lbs	.032 AL	-	TA126XXA	TA12601A	79 lbs

MINOR RIB PANEL • 18" COVERAGE

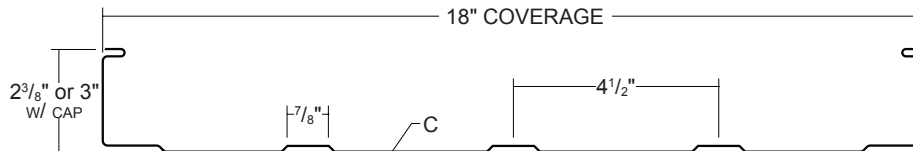

GAUGES	2 3/8" RIB HEIGHT			WEIGHT PER SQ.	GAUGES	3" RIB HEIGHT			WEIGHT PER SQ.
	ACG	PVDF	BARE ALUM.			ACG	PVDF	BARE ALUM.	
24 GA	TA12341	TA123XX	-	146 lbs	24 GA	TA12741	TA127XX	-	152 lbs
22 GA	TA22341	TA223XX	-	186 lbs	22 GA	TA22741	TA227XX	-	194 lbs
.032 AL	-	TA123XXA	TA12301A	72 lbs	.032 AL	-	TA127XXA	TA12701A	75 lbs

Panel weight includes the panel cap and panel clips at a 48" spacing.

STRIATED PANEL • 12" COVERAGE



GAUGES	2 3/8" RIB HEIGHT			WEIGHT PER SQ.	GAUGES	3" RIB HEIGHT			WEIGHT PER SQ.
	ACG	PVDF	BARE ALUM.			ACG	PVDF	BARE ALUM.	
24 GA	TA13141	TA131XX	-	172 lbs	24 GA	TA13541	TA135XX	-	182 lbs
22 GA	TA23141	TA231XX	-	218 lbs	22 GA	TA23541	TA235XX	-	231 lbs
.032 AL	-	TA131XXA	TA13101A	86 lbs	.032 AL	-	TA135XXA	TA13501A	90 lbs

STRIATED PANEL • 16" COVERAGE

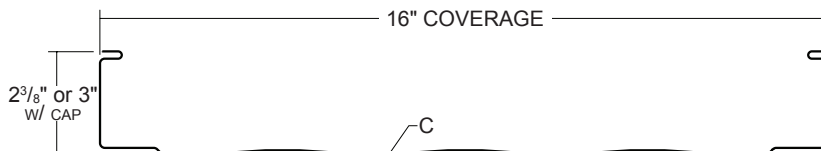

GAUGES	2 3/8" RIB HEIGHT			WEIGHT PER SQ.	GAUGES	3" RIB HEIGHT			WEIGHT PER SQ.
	ACG	PVDF	BARE ALUM.			ACG	PVDF	BARE ALUM.	
24 GA	TA13241	TA132XX	-	152 lbs	24 GA	TA13641	TA136XX	-	160 lbs
22 GA	TA23241	TA232XX	-	194 lbs	22 GA	TA23641	TA236XX	-	203 lbs
.032 AL	-	TA132XXA	TA13201A	75 lbs	.032 AL	-	TA136XXA	TA13601A	79 lbs

STRIATED PANEL • 18" COVERAGE

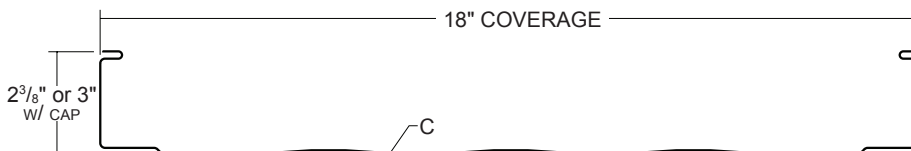

GAUGES	2 3/8" RIB HEIGHT			WEIGHT PER SQ.	GAUGES	3" RIB HEIGHT			WEIGHT PER SQ.
	ACG	PVDF	BARE ALUM.			ACG	PVDF	BARE ALUM.	
24 GA	TA13341	TA133XX	-	146 lbs	24 GA	TA13741	TA137XX	-	152 lbs
22 GA	TA23341	TA233XX	-	186 lbs	22 GA	TA23741	TA237XX	-	194 lbs
.032 AL	-	TA133XXA	TA13301A	72 lbs	.032 AL	-	TA137XXA	TA13701A	75 lbs

Panel weight includes the panel cap and panel clips at a 48" spacing.

MESA PANEL • 12" COVERAGE

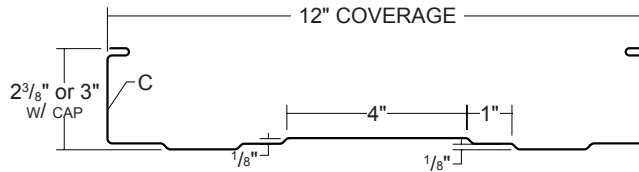

GAUGES	2 ³ / ₈ " RIB HEIGHT			WEIGHT PER SQ.	GAUGES	3" RIB HEIGHT			WEIGHT PER SQ.
	ACG	PVDF	BARE ALUM.			ACG	PVDF	BARE ALUM.	
24 GA	TA14141	TA141XX	-	172 lbs	24 GA	TA14541	TA145XX	-	182 lbs
22 GA	TA24141	TA241XX	-	218 lbs	22 GA	TA24541	TA245XX	-	231 lbs
.032 AL	-	TA141XXA	TA14101A	86 lbs	.032 AL	-	TA145XXA	TA14501A	90 lbs

MESA PANEL • 16" COVERAGE

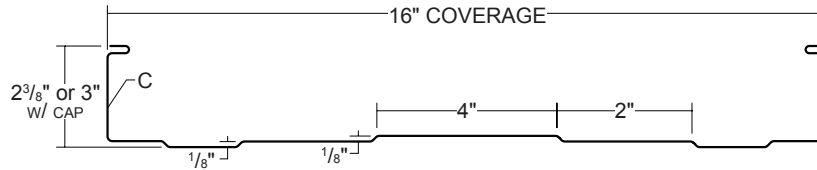

GAUGES	2 ³ / ₈ " RIB HEIGHT			WEIGHT PER SQ.	GAUGES	3" RIB HEIGHT			WEIGHT PER SQ.
	ACG	PVDF	BARE ALUM.			ACG	PVDF	BARE ALUM.	
24 GA	TA14241	TA142XX	-	152 lbs	24 GA	TA14641	TA146XX	-	160 lbs
22 GA	TA24241	TA242XX	-	194 lbs	22 GA	TA24641	TA246XX	-	203 lbs
.032 AL	-	TA142XXA	TA14201A	75 lbs	.032 AL	-	TA146XXA	TA14601A	79 lbs

MESA PANEL • 18" COVERAGE

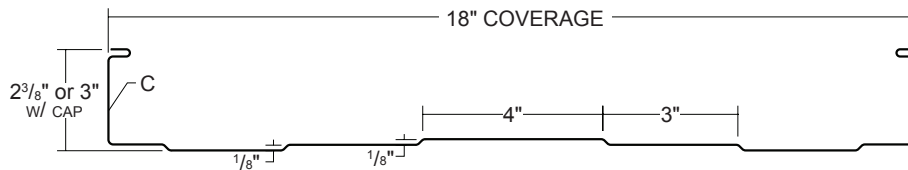

GAUGES	2 ³ / ₈ " RIB HEIGHT			WEIGHT PER SQ.	GAUGES	3" RIB HEIGHT			WEIGHT PER SQ.
	ACG	PVDF	BARE ALUM.			ACG	PVDF	BARE ALUM.	
24 GA	TA14341	TA143XX	-	146 lbs	24 GA	TA14741	TA147XX	-	152 lbs
22 GA	TA24341	TA243XX	-	186 lbs	22 GA	TA24741	TA247XX	-	194 lbs
.032 AL	-	TA143XXA	TA14301A	72 lbs	.032 AL	-	TA147XXA	TA14701A	75 lbs

Panel weight includes the panel cap and panel clips at a 48" spacing.

PLANK PANEL • 12" COVERAGE

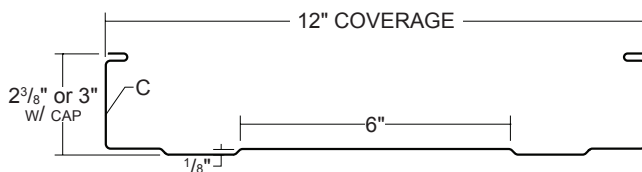

2 3/8" RIB HEIGHT					3" RIB HEIGHT				
GAUGES	ACG	PVDF	BARE ALUM.	WEIGHT PER SQ.	GAUGES	ACG	PVDF	BARE ALUM.	WEIGHT PER SQ.
24 GA	TA15141	TA151XX	-	172 lbs	24 GA	TA15541	TA155XX	-	182 lbs
22 GA	TA25141	TA251XX	-	218 lbs	22 GA	TA25541	TA255XX	-	231 lbs
.032 AL	-	TA151XXA	TA15101A	86 lbs	.032 AL	-	TA155XXA	TA15501A	90 lbs

PLANK PANEL • 16" COVERAGE

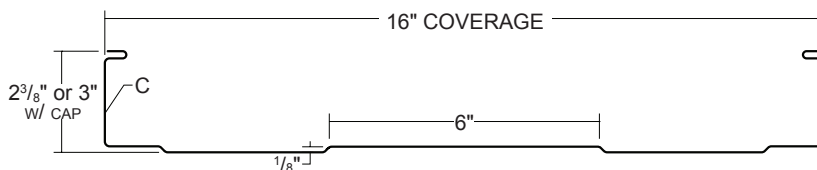

2 3/8" RIB HEIGHT					3" RIB HEIGHT				
GAUGES	ACG	PVDF	BARE ALUM.	WEIGHT PER SQ.	GAUGES	ACG	PVDF	BARE ALUM.	WEIGHT PER SQ.
24 GA	TA15241	TA152XX	-	152 lbs	24 GA	TA15641	TA156XX	-	160 lbs
22 GA	TA25241	TA252XX	-	194 lbs	22 GA	TA25641	TA256XX	-	203 lbs
.032 AL	-	TA152XXA	TA15201A	75 lbs	.032 AL	-	TA156XXA	TA15601A	79 lbs

PLANK PANEL • 18" COVERAGE

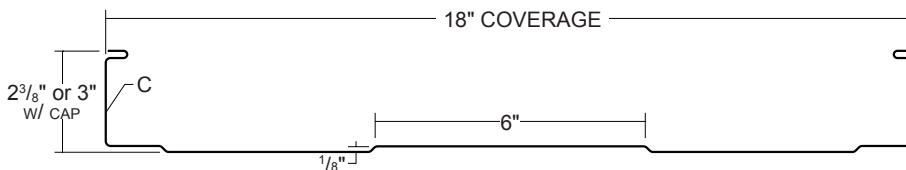

2 3/8" RIB HEIGHT					3" RIB HEIGHT				
GAUGES	ACG	PVDF	BARE ALUM.	WEIGHT PER SQ.	GAUGES	ACG	PVDF	BARE ALUM.	WEIGHT PER SQ.
24 GA	TA15341	TA153XX	-	146 lbs	24 GA	TA15741	TA157XX	-	152 lbs
22 GA	TA25341	TA253XX	-	186 lbs	22 GA	TA25741	TA257XX	-	194 lbs
.032 AL	-	TA153XXA	TA15301A	72 lbs	.032 AL	-	TA157XXA	TA15701A	75 lbs

Panel weight includes the panel cap and panel clips at a 48" spacing.

T-ARMOR CAP

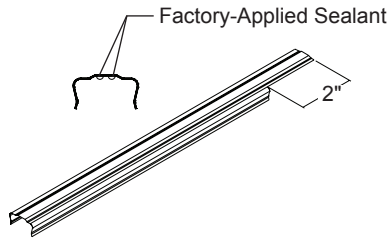

Caps come in the same length as panels unless otherwise specified.

DESCRIPTION	GAUGE	PRODUCT NO.	FINISH	WT/FT
Mechanically Seamed	24	TAC01XX	PVDF/ACG	0.16 lbs
	22	TAC02XX	PVDF/ACG	0.21 lbs
Mechanically Seamed	.032	TAC01XXA	PVDF	0.08 lbs
	.032	TAC0101A	Bare Alum.	0.08 lbs

T-ARMOR CLIP

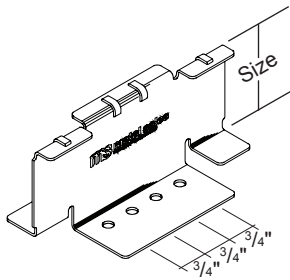

SIZE	TYPE	PRODUCT NO.	CARTON QUANTITY	WT/ CARTON
2 ³ / ₈ "	2 ³ / ₈ " Utility	3640900	100 pieces	35 lbs
2 ³ / ₄ "	2 ³ / ₈ " Low	3641000	100 pieces	40lbs
3 ³ / ₄ "	2 ³ / ₈ " High	3641200	100 pieces	45 lbs
3"	3" Utility	3641100	100 pieces	45 lbs
3 ³ / ₈ "	3" Low	3641300	100 pieces	50 lbs
4 ³ / ₈ "	3" High	3641400	100 pieces	55 lbs

THERMAL BLOCKS

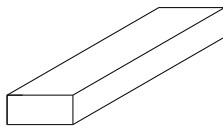

SIZE	TYPE	PRODUCT NO.	WT/100
3/8" x 3" x 12"	Polystyrene Foam	4923777	1.25 lbs
3/8" x 3" x 16"	Polystyrene Foam	4923787	1.50 lbs
3/8" x 3" x 18"	Polystyrene Foam	4923775	1.75 lbs
1" x 3" x 12"	Polystyrene Foam	4923778	2.75 lbs
1" x 3" x 16"	Polystyrene Foam	4923760	3.00 lbs
1" x 3" x 18"	Polystyrene Foam	4923770	3.50 lbs

FLOATING RAKE ANGLE

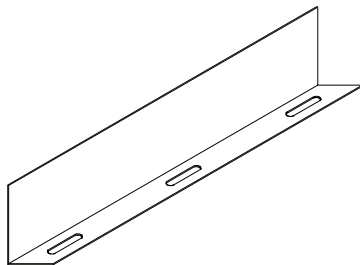

SIZE	FINISH	LENGTH	PRODUCT NO.	WT
2 ⁵ / ₈ " x 16 Ga	Galvanized	10'-0"	4923810	10.7 lbs
3 ¹ / ₈ " x 16 Ga	Galvanized	10'-0"	4923815	10.9 lbs
3 ³ / ₄ " x 16 Ga	Galvanized	10'-0"	4923821	11.9 lbs
4 ¹ / ₈ " x 16 Ga	Galvanized	10'-0"	4923825	13.0 lbs

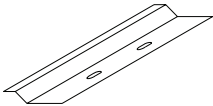
EAVE PLATE	SIZE	FINISH	TYPE	PRODUCT NO.	WT
	1/4" x 16 Ga.	Galvanized	Utility 6'-0"	4923829	4.1 lbs
	3/8" x 16 Ga.	Galvanized	Low 10'-0"	4923835	7.8 lbs
	1 3/8" x 16 Ga.	Galvanized	High 10'-0"	4923845	10.1 lbs

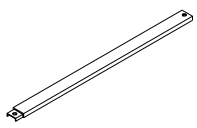
BACK-UP CHANNEL	SIZE	FINISH	LENGTH	PRODUCT NO.	WT
	3" x 3/8"	Galvanized	48"	4923640	2.8 lbs
	3" x 3/8"	Galvanized	72"	4923645	4.1 lbs

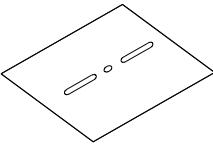
BEARING PLATE	SIZE	FINISH	PRODUCT NO.	WT/100
	4" x 5" x 20 Ga.	Galvanized	4923886	30 lbs

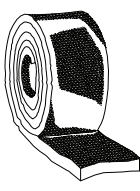
ENDLAP PAD	SIZE	TYPE	PRODUCT NO.	WT/CARTON
	1 1/2" x 3/32" x 30'	Butyl	6411999	27 lbs

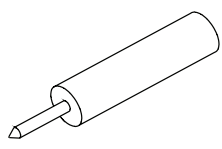
TUBE SEALANT	SIZE	COLOR	PRODUCT NO.	CARTON QUANTITY	WT/ CARTON
	10.3 oz	Urethane White	6402830	30 cartridges	19.3 lbs
	10.3 oz	Urethane Bronze	6402999	30 cartridges	19.3 lbs
	10.3 oz	Urethane Gray	6402829	30 cartridges	19.3 lbs
	10.3 oz	Acrylic Clear	6402800	30 cartridges	19.3 lbs

STIFFENER PLATE	SIZE	FINISH	GAUGE	PRODUCT NO.	WT/10
	3/4" x 4"	Galvanized	16	3633900	0.55 lbs

DOUBLE BEAD TAPE SEALANT	SIZE	TYPE	PRODUCT NO.	CARTON QUANTITY	WT/ CARTON
--------------------------	------	------	-------------	-----------------	------------

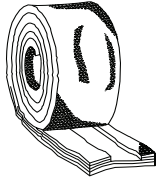

$7/8"$ x $3/16"$ x 25' Butyl 6403899 20 rolls 46.8 lbs

VENT MATERIAL	SIZE	TYPE	PRODUCT NO.	CARTON QUANTITY	WT/ CARTON
---------------	------	------	-------------	-----------------	------------

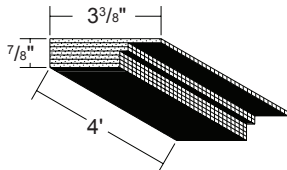

$3^{5/16}"$ x $7/8"$ x 4' Black 6852406 24 pieces 30.0 lbs

Use on roof with a 3:12 or greater slope.

TOUCH-UP PAINT	TYPE	SIZE	PRODUCT NO.	WT
----------------	------	------	-------------	----



For PVDF finish 2 oz. Bottle 66005_ _ 0.15 lbs

_ _ Represents color code designation.

ms-HT UNDERLAYMENT	TYPE	SIZE	PRODUCT NO.	WT/ ROLL
--------------------	------	------	-------------	----------

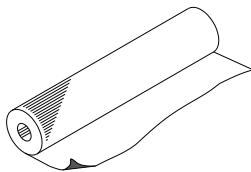

Peel-and-Stick 36" x 66.67' (2 Sq Roll) 4121200 44.0 lbs

UNDERLAYMENT PRIMER	SIZE	PRODUCT NO.	WT/ ROLL
---------------------	------	-------------	----------



5 Gallon* 6600000 42.0 lbs

Coverage is 100 to 125 ft² per gallon depending on substrate.

HEMMING/TURN-UP TOOL	TYPE	SIZE	PRODUCT NO.	WT/100
----------------------	------	------	-------------	--------

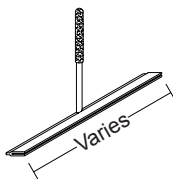

24" Panel 20" 6560102 3.3 lbs
 18" Panel 17" 6560122 2.9 lbs
 16" Panel 15" 6560132 2.6 lbs
 12" Panel 11" 6560142 2.1 lbs

Used for bending lower end of the metal panel to accept Offset Cleat flashing for concealed fastener application or for turning up the end of the panel at the high side.

POST HUNG GUTTER HANGER	SIZE	FINISH	TYPE	PRODUCT NO.	WT
-------------------------	------	--------	------	-------------	----

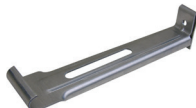

6" x 16 Ga. Galvanized Galv 3633800 0.2 lbs

RUBBER ROOF DECK FLASHINGS

TYPE	SIZE	BASE DIAM.	PRODUCT NO.	WT
Rubber	#1 Flasher	1/4" - 2"	68501__*	3.0 lbs
Rubber	#2 Flasher	1 3/4" - 3 1/4"	68502__*	3.0 lbs
Rubber	#3 Flasher	1/4" - 5"	68503__*	3.0 lbs
Rubber	#4 Flasher	3" - 6 1/4"	68504__*	3.0 lbs
Rubber	#5 Flasher	4 1/4" - 7 1/2"	68505__*	5.0 lbs
Rubber	#6 Flasher	5" - 9"	68506__*	9.0 lbs
Rubber	#7 Flasher	6" - 11"	68507__*	11.0 lbs
Rubber	#8 Flasher	7" - 13"	68508__*	13.0 lbs
Rubber	#9 Flasher	10" - 19"	68509__*	13.0 lbs

Special order colors: 93=Brown; 94=Green; 95=Red; 96=Blue; 97=White; 98=Grey; 99=Black

ROUND

Rubber Roof Jack Round Base

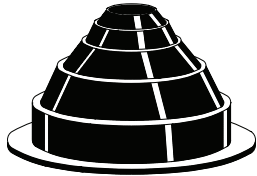

HT Silicone	#1 Flasher	1/4" - 2"	6850011	3.0 lbs
HT Silicone	#2 Flasher	1 3/4" - 3 1/4"	6850012	3.0 lbs
HT Silicone	#3 Flasher	1/4" - 5"	6850013	3.0 lbs
HT Silicone	#4 Flasher	3" - 6 1/4"	6850014	3.0 lbs
HT Silicone	#5 Flasher	4 1/4" - 7 1/2"	6850015	5.0 lbs
HT Silicone	#6 Flasher	5" - 9"	6850016	9.0 lbs
HT Silicone	#7 Flasher	6" - 11"	6850017	11.0 lbs
HT Silicone	#8 Flasher	7" - 13"	6850018	13.0 lbs
HT Silicone	#9 Flasher	10" - 19"	6850019	13.0 lbs
Retrofit HT	#1 Masterflash	1/4" - 2"	6850060	4.0 lbs
Retrofit HT	#2 Masterflash	1 1/4" - 3"	6850061	4.0 lbs
Retrofit HT	#3 Masterflash	1/4" - 4"	6850062	4.0 lbs

GRAY ROUND RETRO ROOF JACK

Retrofit E.P.D.M.	#1 Masterflash	1/4" - 2"	6850070	4.0 lbs
Retrofit E.P.D.M.	#2 Masterflash	1 1/4" - 3"	6850071	4.0 lbs
Retrofit E.P.D.M.	#3 Masterflash	1/4" - 4"	6850072	4.0 lbs

BLACK ROUND RETRO ROOF JACK

Retrofit E.P.D.M.	#1 Masterflash	1/4" - 2"	6850073	4.0 lbs
Retrofit E.P.D.M.	#2 Masterflash	1 1/4" - 3"	6850074	4.0 lbs
Retrofit E.P.D.M.	#3 Masterflash	1/4" - 4"	6850075	4.0 lbs

SQUARE

Retro Roof Jack Square Base

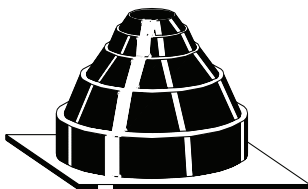

BLACK SQUARE RETRO ROOF JACK				
Retrofit E.P.D.M.	#1 Masterflash	1/4" - 2"	6850046	4.0 lbs
Retrofit E.P.D.M.	#2 Masterflash	1 1/4" - 3"	6850047	4.0 lbs
Retrofit E.P.D.M.	#3 Masterflash	1/4" - 4"	6850048	4.0 lbs

Kit includes: membrane fasteners, termination strips, splice material and sealant. (Deck Flashing temperature range is -65° to +250°; HT Deck Flashing temperature range is -100° to +450°).

VENTED RIDGE COVER	GAUGE	FINISH	PRODUCT NO.	WT	LENGTH	
	24	ACG	5701341	13.3 lbs	10'-2"	
	24	ACG	5701541	26.5 lbs	20'-3"	
	24	PVDF	58013__	13.3 lbs	10'-2"	
	24	PVDF	58015__	26.5 lbs	20'-3"	
	* See chart on page 6.					

VENT DRIP	GAUGE	FINISH	PRODUCT NO.	WT	LENGTH
	24	ACG	5701741	3.8 lbs	10'-2"
	24	PVDF	58017__	3.8 lbs	10'-2"

SSR RIDGE	GAUGE	FINISH	PRODUCT NO.	WT	LENGTH	
	24	ACG	5775141	14.7 lbs	10'-2"	
	24	ACG	5775341	29.7 lbs	20'-3"	
	24	PVDF	58751__	14.7 lbs	10'-2"	
	24	PVDF	58753__	29.7 lbs	20'-3"	
	* See chart on page 6.					

7" RIDGE/HIP COVER	GAUGE	FINISH	PRODUCT NO.	WT	LENGTH	
	24	ACG	5854441	12.7 lbs	10'-2"	
	24	ACG	5855441	25.4 lbs	20'-3"	
	24	PVDF	58544__	12.7 lbs	10'-2"	
	24	PVDF	58554__	25.4 lbs	20'-3"	
	* See chart on page 6.					

EXPANSION JOINT	GAUGE	FINISH	PRODUCT NO.	WT	LENGTH
	24	ACG	6372241	14.7 lbs	10'-2"
	24	ACG	6372341	29.3 lbs	20'-3"
	24	PVDF	64722__	14.7 lbs	10'-2"
	24	PVDF	64723__	29.3 lbs	20'-3"

W-VALLEY	GAUGE	FINISH	PRODUCT NO.	WT	LENGTH
	24	ACG	5213641	15.9 lbs	10'-2"
	24	PVDF	52136__	15.9 lbs	10'-2"
* See chart on page 6.					

4.5" DROP VALLEY	GAUGE	FINISH	PRODUCT NO.	WT	LENGTH									
<table border="1" style="margin-top: 10px;"> <thead> <tr> <th>SYSTEM</th> <th>A</th> <th>B</th> </tr> </thead> <tbody> <tr> <td>LOW</td> <td>3/4"</td> <td>4 3/4"</td> </tr> <tr> <td>HIGH</td> <td>2 3/4"</td> <td>2 3/4"</td> </tr> </tbody> </table>	SYSTEM	A	B	LOW	3/4"	4 3/4"	HIGH	2 3/4"	2 3/4"	Low 4.5" Drop Valley				
	SYSTEM	A	B											
	LOW	3/4"	4 3/4"											
	HIGH	2 3/4"	2 3/4"											
	24	ACG	5781741	19.1 lbs	10'-2"									
	24	ACG	5781941	38.0 lbs	20'-3"									
	24	PVDF	58817__	19.1 lbs	10'-2"									
	24	PVDF	58819__	38.0 lbs	20'-3"									
	High 4.5" Drop Valley													
	24	ACG	5782341	19.1 lbs	10'-2"									
	24	ACG	5782541	38.0 lbs	20'-3"									
	24	PVDF	58823__	19.1 lbs	10'-2"									
24	PVDF	58825__	38.0 lbs	20'-3"										
* See chart on page 6														

9" DROP VALLEY

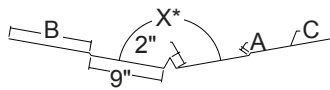

SYSTEM	A	B
LOW	3/4"	5"
HIGH	2 3/4"	3"

GAUGE	FINISH	PRODUCT NO.	WT	LENGTH
Low 9" Drop Valley				
24	ACG	5786341	26.7 lbs	10'-2"
24	ACG	5786441	53.1 lbs	20'-3"
24	PVDF	58863__	26.7 lbs	10'-2"
24	PVDF	58864__	53.1 lbs	20'-3"
High 9" Drop Valley				
24	ACG	5786741	26.7 lbs	10'-2"
24	ACG	5786841	53.1 lbs	20'-3"
24	PVDF	58867__	26.7 lbs	10'-2"
24	PVDF	58868__	53.1 lbs	20'-3"

* See chart on page 6.

T-ARMOR PEAK

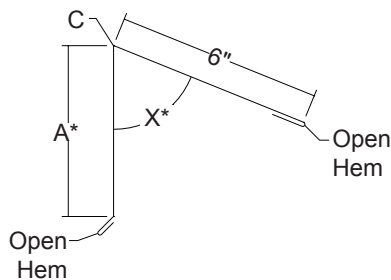

* "A" dimension will vary per slope
See chart on page 6.
Weight varies.

GAUGE	FINISH	PRODUCT NO.	DESCRIPTION	LENGTH
24	PVDF	58551__	2 3/8" Utility	10'-2"
24	ACG	5855141	2 3/8" Utility	10'-2"
24	PVDF	58522__	2 3/8" Low	10'-2"
24	ACG	5852241	2 3/8" Low	10'-2"
24	PVDF	58523__	2 3/8" High	10'-2"
24	ACG	5852341	2 3/8" High	10'-2"
24	PVDF	58524__	3" Utility	10'-2"
24	ACG	5852441	3" Utility	10'-2"
24	PVDF	58525__	3" Low	10'-2"
24	ACG	5852541	3" Low	10'-2"
24	PVDF	58526__	3" High	10'-2"
24	ACG	5852641	3" High	10'-2"

SSR SCULPTURED HIGH SIDE EAVE

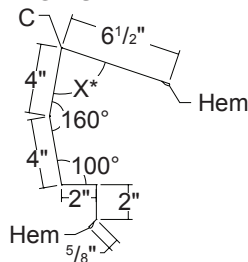

GAUGE	FINISH	PRODUCT NO.	WT	LENGTH
24	ACG	5776941	15.9 lbs	10'-2"
24	ACG	5777141	31.7 lbs	20'-3"
24	PVDF	58769__	15.9 lbs	10'-2"
24	PVDF	58771__	31.7 lbs	20'-3"

* See chart on page 6.

T-ARMOR EAVE

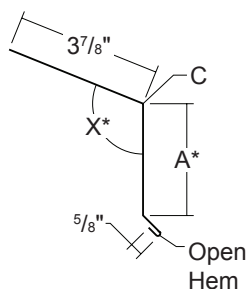

* "A" dimension will vary per slope.
See chart on page 6.

GAUGE	FINISH	PRODUCT NO.	WT	LENGTH
24	ACG	5706541	6.3 lbs	10'-2"
24	PVDF	58065__	6.3 lbs	10'-2"

Weight Varies with slope.

T-ARMOR SCULPTURED EAVE

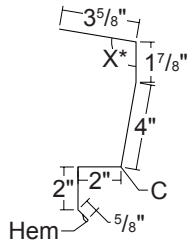

GAUGE	FINISH	PRODUCT NO.	WT	LENGTH
24	ACG	5783541	11.5 lbs	10'-2"
24	ACG	5783741	23.0 lbs	20'-3"
24	PVDF	58835__	11.5 lbs	10'-2"
24	PVDF	58837__	23.0 lbs	20'-3"

* See chart on page 6.

T-ARMOR RAKE

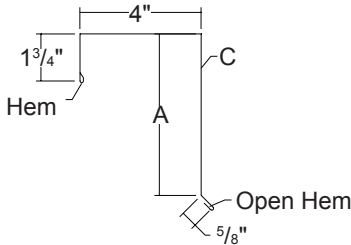

2 3/8" Panel		3" Panel	
System	A	System	A
Utility	5 5/8"	Utility	6 1/4"
Low	5 7/8"	Low	6 1/2"
High	6 7/8"	High	7 1/2"

Weight Varies with size.

GAUGE	FINISH	PRODUCT NO.	DESCRIPTION	LENGTH
24	PVDF	58537__	2 3/8" Utility	10'-2"
24	ACG	5853741	2 3/8" Utility	10'-2"
24	PVDF	58538__	2 3/8" Low	10'-2"
24	ACG	5853841	2 3/8" Low	10'-2"
24	PVDF	58539__	2 3/8" High	10'-2"
24	ACG	5853941	2 3/8" High	10'-2"
24	PVDF	58540__	3" Utility	10'-2"
24	ACG	5854041	3" Utility	10'-2"
24	PVDF	58541__	3" Low	10'-2"
24	ACG	5854141	3" Low	10'-2"
24	PVDF	58542__	3" High	10'-2"
24	ACG	5854241	3" High	10'-2"

OFFSET RAKE SLIDE

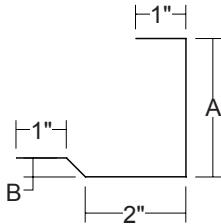

2 3/8" Panel			3" Panel		
System	A	B	System	A	B
Utility	2 5/8"	1/4"	Utility	3 1/4"	1/4"
Low	2 7/8"	3/8"	Low	3 1/2"	3/8"
High	3 7/8"	1 3/8"	High	4 1/2"	1 3/8"

GAUGE	PRODUCT NO.	DESCRIPTION	LENGTH	WT
24	5853199	2 3/8" Utility	10'-2"	5.9 lbs
24	5853299	2 3/8" Low	10'-2"	6.1 lbs
24	5853399	2 3/8" High	10'-2"	7.4 lbs
24	5853499	3" Utility	10'-2"	6.4 lbs
24	5853599	3" Low	10'-2"	6.6 lbs
24	5853699	3" High	10'-2"	7.9 lbs

Supplied in various colors.

SSR RAKE SLIDE

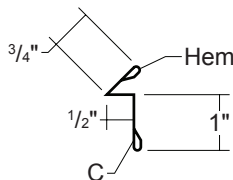

GAUGE	FINISH	PRODUCT NO.	WT	LENGTH
24	ACG	5776541	2.4 lbs	10'-2"
24	PVDF	58765__	2.4 lbs	10'-2"

STARTER

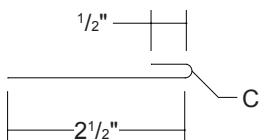

GAUGE	FINISH	PRODUCT NO.	WT	LENGTH
24	ACG	5706241	2.5 lbs	10'-2"
24	PVDF	58062__	2.5 lbs	10'-2"

	GAUGE	FINISH	PRODUCT NO.	WT	LENGTH
	24	ACG	5775941	15.8 lbs	10'-2"
	24	ACG	5776141	31.5 lbs	20'-3"
	24	PVDF	58759__	15.8 lbs	10'-2"
	24	PVDF	58761__	31.5 lbs	20'-3"
	Closed Hem				
	Hem				
	24	ACG	5776341	0.2 lbs	
	24	PVDF	58763__	0.2 lbs	
	24	ACG	5855641	8.6 lbs	10'-2"
	24	ACG	5855841	17.2 lbs	20'-3"
	24	PVDF	58556__	8.6 lbs	10'-2"
	24	PVDF	58558__	17.2 lbs	20'-3"
	Open Hem				
	Closed Hem				
	24	ACG	5777341	11.3 lbs	10'-2"
	24	ACG	5777541	22.6 lbs	20'-3"
	24	PVDF	58773__	11.3 lbs	10'-2"
	24	PVDF	58775__	22.6 lbs	20'-3"
	Open Hem				
	* See chart on page 6.				
	24	ACG	5705241	3.1 lbs	10'-2"
	24	PVDF	58052__	3.1 lbs	10'-2"
	24	ACG	5705441	3.2 lbs	10'-2"
	24	PVDF	58054__	3.2 lbs	10'-2"

BOX GUTTER	GAUGE	FINISH	PRODUCT NO.	WT	LENGTH	
	24	ACG	5707741	16.9 lbs	10'-2"	
	24	ACG	5707941	33.7 lbs	20'-3"	
	24	PVDF	58077__	16.9 lbs	10'-2"	
	24	PVDF	58079__	33.7 lbs	20'-3"	
	* See chart on page 6.					

POST HUNG GUTTER	GAUGE	FINISH	PRODUCT NO.	WT	LENGTH
	24	ACG	5853041	15.1 lbs	10'-2"
	24	ACG	5853141	30.0 lbs	20'-3"
	24	PVDF	58530__	15.1 lbs	10'-2"
	24	PVDF	58531__	30.0 lbs	20'-3"

BOX GUTTER END	GAUGE	FINISH	PRODUCT NO.	WT
	24	ACG	5708141 (Left) 5708241 (Right)	0.3 lbs
	24	PVDF	58081__ (Left) 58082__ (Right)	0.3 lbs

POST HUNG GUTTER END	GAUGE	FINISH	PRODUCT NO.	WT
	24	ACG	5848141 (Left) 5848241 (Right)	0.3 lbs
	24	PVDF	58481__ (Left) 58482__ (Right)	0.3 lbs

SSR GUTTER DRIP	GAUGE	FINISH	PRODUCT NO.	WT	LENGTH
	24	ACG	5778141	6.4 lbs	10'-2"
	24	PVDF	58781__	6.4 lbs	10'-2"
* See chart on page 6.					

UNIVERSAL GUTTER/ DOWNSPOUT STRAP	GAUGE	FINISH	PRODUCT NO.	WT	LENGTH
	24	ACG	5709241	.36 lbs	1'-4"
	24	PVDF	58092__	.36 lbs	1'-4"

4" x 6" DOWNSPOUT	GAUGE	FINISH	PRODUCT NO.	WT	LENGTH
	24	ACG	5709841	16.7 lbs	10'-2"
	24	ACG	5710141	33.3 lbs	20'-3"
	24	PVDF	58098__	16.7 lbs	10'-2"
	24	PVDF	58101__	33.3 lbs	20'-3"

3 1/2" x 4" DOWNSPOUT	GAUGE	FINISH	PRODUCT NO.	WT	LENGTH
	24	ACG	5709441	12.7 lbs	10'-2"
	24	ACG	5709741	25.4 lbs	20'-3"
	24	PVDF	58094__	12.7 lbs	10'-2"
	24	PVDF	58097__	25.4 lbs	20'-3"

4" DOWNSPOUT BRACKET	GAUGE	FINISH	PRODUCT NO.	WT
	24	ACG	5711041	0.1 lbs
	24	PVDF	58110__	0.1 lbs

6" DOWNSPOUT BRACKET	GAUGE	FINISH	PRODUCT NO.	WT
	24	ACG	5711241	0.1 lbs
	24	PVDF	58112__	0.1 lbs

ELBOWS	GAUGE	FINISH	PRODUCT NO.	WT
3 1/2" x 4" ELBOWS (D x W)				
	95 DEGREE			
	24	ACG	5710241	2.3 lbs
	24	PVDF	58102__	2.3 lbs
	45 DEGREE			
	24	ACG	5710641	2.3 lbs
	24	PVDF	58106__	2.3 lbs
	4"x 6" ELBOWS (D x W)			
	95 DEGREE			
	24	ACG	5710441	3.0 lbs
	24	PVDF	58104__	3.0 lbs
	45 DEGREE			
	24	ACG	5710841	3.0 lbs
	24	PVDF	58108__	3.0 lbs

TYPE A ELBOWS

TYPE B ELBOWS

Notes:

Type "A" & "B" has seam on heel. Specify otherwise at time of order.

OFFSET CLEAT

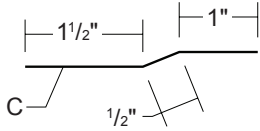

GAUGE	FINISH	PRODUCT NO.	WT	LENGTH
24	Supplied in Various Colors	5806499	2.4 lbs	10'-2"

CLEAT

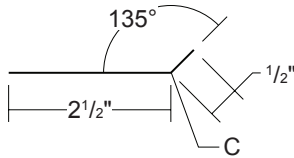

GAUGE	FINISH	PRODUCT NO.	WT	LENGTH
24	Supplied in Various Colors	5806099	2.4 lbs	10'-2"

2 3/8" T-ARMOR Z-CLOSURE

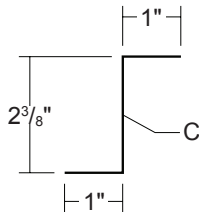

GAUGE	FINISH	PRODUCT NO.	WT	LENGTH
24	ACG	5854541	3.5 lbs	10'-2"
24	PVDF	58545__	3.5 lbs	10'-2"

3" T-ARMOR Z-CLOSURE

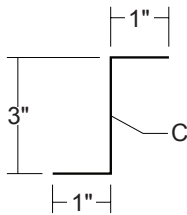

GAUGE	FINISH	PRODUCT NO.	WT	LENGTH
24	ACG	5854641	4.0 lbs	10'-2"
24	PVDF	58546__	4.0 lbs	10'-2"

2 3/8" T-ARMOR RIB COVER

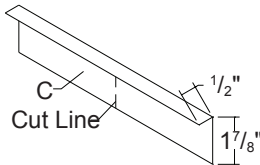

GAUGE	FINISH	PRODUCT NO.	WT	LENGTH
24	PVDF	58547__	0.1 lbs	8"
24	ACG	5854741	0.1 lbs	8"
22	PVDF	60547__	0.2 lbs	8"
22	ACG	6054741	0.2 lbs	8"

For use on panel with a eave to wall transition (knee cap). Two Rib Covers are required per panel.

3" T-ARMOR RIB COVER

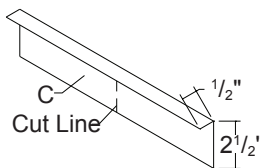

GAUGE	FINISH	PRODUCT NO.	WT	LENGTH
24	PVDF	58549__	0.2 lbs	8"
24	ACG	5854941	0.2 lbs	8"
22	PVDF	60549__	0.2 lbs	8"
22	ACG	6054941	0.2 lbs	8"

For use on panel with a eave to wall transition (knee cap). Two Rib Covers are required per panel.

ROOF CLEAT

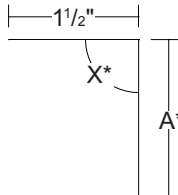



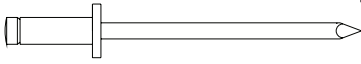
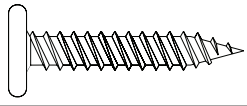
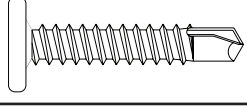
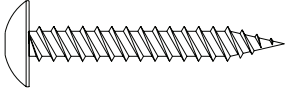
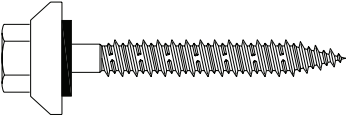
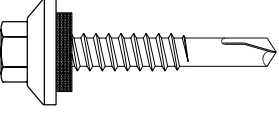
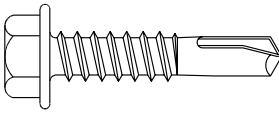
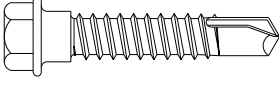
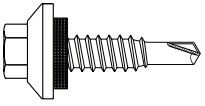
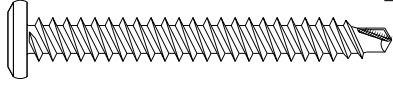
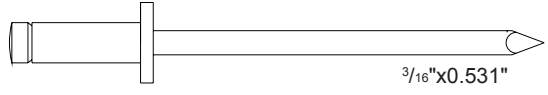

GAUGE	FINISH	PRODUCT NO.	WT	LENGTH
24	Supplied in Various Colors	5854399	2.4 lbs	10'-2"



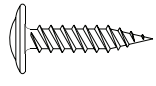
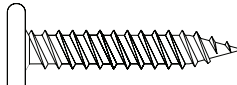

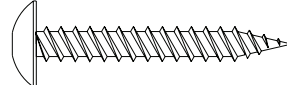
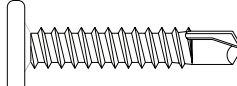
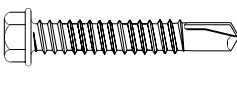
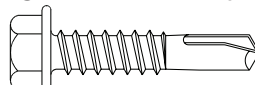
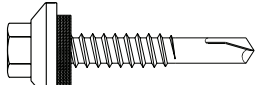
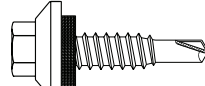
* See chart on page 6.

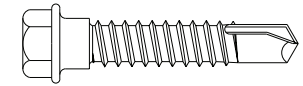
 <p>POP RIVET</p>	SIZE	TYPE	QTY	PRODUCT NO.	FINISH	APPLICATION
	1/8"x 3/8"	A	250	8240201	Unpainted	Flashing to Panel or Flashing
	1/8"x 3/8"	A	250	82402__	Painted	Flashing to Panel or Flashing
 <p>PANCAKE HEAD WOOD SCREW</p>	SIZE	TYPE	QTY	PRODUCT NO.	FINISH	APPLICATION
	#10-12x1"	A	250	8243100	Plated	Flashing to wood decking
 <p>PANCAKE HEAD DRILLER</p>	SIZE	TYPE	QTY	PRODUCT NO.	FINISH	APPLICATION
	#10-16x1"	Driller	250	8242100	Plated	Flashing to metal substructure
 <p>LOW PROFILE WOOD SCREW</p>	SIZE	TYPE	QTY	PRODUCT NO.	FINISH	APPLICATION
	#12-11x1 1/2"	A	250	8244100	Plated	Clips to wood decking
 <p>WOOD SCREW XL</p>	SIZE	TYPE	QTY	PRODUCT NO.	FINISH	APPLICATION
	#10-14x1 1/2"	A	250	8212300	Unpainted	Panel or Flashing to wood substructure
	#10-14x1 1/2"	A	250	82123__	Painted	
 <p>SELF DRILLER XL</p>	SIZE	TYPE	QTY	PRODUCT NO.	FINISH	APPLICATION
	#12-14x1 1/4"	Driller	250	8235300	Unpainted	Panel or Flashing to metal substructure
	#12-14x1 1/4"	Driller	250	82353__	Painted	
 <p>SELF DRILLER NO WASHER</p>	SIZE	TYPE	QTY	PRODUCT NO.	FINISH	APPLICATION
	1/4"-14x1 1/2"	Driller (#2 point)	250	8249300	Plated	Panel clips to metal substructure
	#12-24x1 1/4"	Driller (#4 point)	250	8282000	Plated	Panel clips to bar joists up to 3/8" thick
	#12-14x1"	Driller	250	8242000	Plated	Accessories to metal substructure and used with framing on retrofit
 <p>SHOULDER SELF DRILLER</p>	SIZE	TYPE	QTY	PRODUCT NO.	FINISH	APPLICATION
	1/4"-14x1 1/4"	Driller	250	8281300	Plated	For use with Floating Rake Zee to substructure
 <p>STITCH SCREW XL</p>	SIZE	TYPE	QTY	PRODUCT NO.	FINISH	APPLICATION
	1/4"-14x7/8"	Stitch	250	8236800	Unpainted	Flashing to Panel or Flashing
	1/4"-14x7/8"	Stitch	250	82368__	Painted	
 <p>DECK SCREW</p>	SIZE	TYPE	QTY	PRODUCT NO.	FINISH	APPLICATION
	#14-13x2"-8"	Driller	Contact Sales Branch	Contact Sales Branch	Black	Panel Clip to metal deck and rigid board insulation assembly or wood substructure
 <p>STRUCTURAL RIVET</p>	SIZE	TYPE	QTY	PRODUCT NO.	FINISH	APPLICATION
	3/16"x0.531"	Rivet	250	82611__	Painted	Endlap, Endwall, Ridge See pages 62, 73 and 74

PHYSICAL PROPERTIES

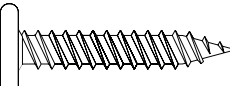
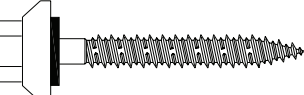
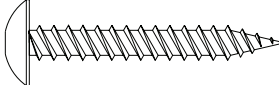
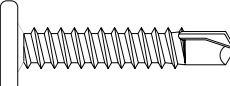
FASTENER	HEAD DIA/TYPE	THREAD DIA. O.D.	THREAD DIA. I.D.	MIN TENSILE	MIN. TORSIONAL	NOM. SHEAR
 <p>TRUSS HEAD WOOD SCREW #8-15x³/₄"</p>	Truss Hd. #2 Philips	.162-.168	.105-.110	1672 lbs	61 In lbs	1087 lbs
 <p>PANCAKE HEAD WOOD SCREW #10-12x1"</p>	.447 IN. #2 Philips Square	.188-.194	.126-.133	1673 lbs	79 In lbs	1311 lbs
 <p>WOOD SCREW XL #10-14x1", 1¹/₂"</p>	1/4" HWH	.175-.181	.127-.133	2429 lbs	80 In lbs	1355 lbs
 <p>LOW PROFILE WOOD SCREW #12-11 x 1¹/₂"</p>	#3 Square Drive	.201-.208	.125-.131	2050 lbs	81 In lbs	1369 lbs
 <p>PANCAKE HEAD DRILLER #10-16x1"</p>	#2 Philips	.183-.189	.135-.141	1984 lbs	80 In lbs	1442 lbs
 <p>SELF DRILLER NO WASHER 1/4"-14x1¹/₂"</p>	5/16" HWH	.240-.246	.185-.192			
 <p>SELF DRILLER NO WASHER #12-14x1", 1¹/₂"</p>	5/16" HWH	.209-.215	.157-.165			
 <p>SELF DRILLER XL #12-14x1", 1¹/₄", 1¹/₂"</p>	5/16" HWH	.209-.215	.157-.165			
 <p>STITCH XL 1/4"-14x⁷/₈"</p>	5/16" HWH	.240-.246	.185-.192			
 <p>DECK SCREW #14-13x2", 4", 5", 6", 8"</p>	#3 Philips .448 Max	.235-.242	.155			
 <p>SHOULDER SELF DRILLER 1/4"-14x1¹/₄"</p>	5/16" HWH	.263-.266	.199-.201			

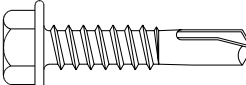
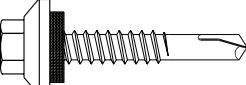
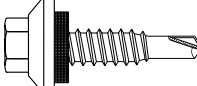
PULL OUT VALUES - POUNDS (RECOMMENDED SAFETY FACTOR)

FASTENER	Plywood			OSB		Hard/Soft Wood			
	3/4"	5/8"	1/2"	19/32"	7/16"	Spruce	Fir	Oak	Pine
TRUSS HEAD WOOD SCREW  #8-15x ³ / ₄ "	461	340	377		98	375	405	593	464
PANCAKE HEAD WOOD SCREW  #10-12x1"	615	521	339	290	257				
WOOD SCREW XL  #10-14x1", 1 ¹ / ₂ "	565	498	326		223	1537			
LOW PROFILE WOOD SCREW  #12-11 x1 ¹ / ₂ "									
FASTENER				Steel					
	3/8"	1/4"	3/16"	10 GA	12 GA (55)	14 GA (55)	16 GA (55)	18 GA (50)	22 GA (50)
PANCAKE HEAD DRILLER  #10-16x1"					1514 (2.59)	953 (2.54)	825 (2.54)		167 (2.69)
SELF DRILLER NO WASHER  1/4"-14x1 ¹ / ₂ "					2031 (2.55)	1172 (2.54)	1043 (2.55)	951 (2.62)	209 (2.68)
SELF DRILLER NO WASHER  #12-14x1", 1 ¹ / ₂ "					1788 (2.54)	1056 (2.54)	850 (3.10)	790 (2.60)	180 (2.76)
SELF DRILLER XL  #12-14x1", 1 ¹ / ₄ ", 1 ¹ / ₂ "									
STITCH XL  1/4"-14x7/8"									
DECK SCREW  #14-13x2", 4", 5", 6", 8"									
SHOULDER SELF DRILLER  1/4"-14x1 ¹ / ₄ "									

PULL OVER STRENGTH VALUES (POUNDS ULTIMATE)

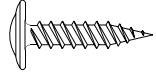
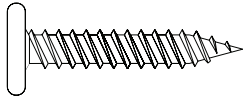
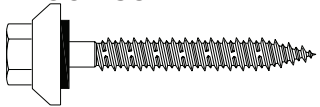
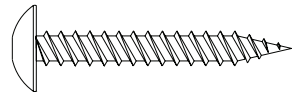
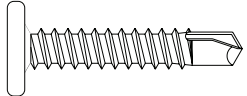
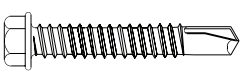
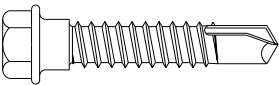
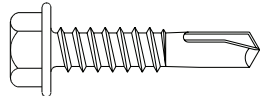
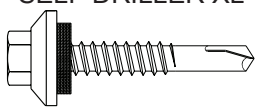
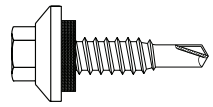
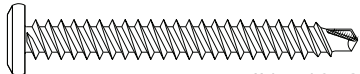
FASTENER	STEEL					
	20 GA	22 GA (50)	24 GA (50)	26 GA (80)	26 GA (50)	29 GA (80)
 TRUSS HEAD WOOD SCREW #8-15x ³ / ₄ "		N/A	852 (2.57)	693 (2.64)	619 (2.60)	546 (2.83)
 PANCAKE HEAD WOOD SCREW #10-12x1"		1129 (2.56)	843 (2.55)	658 (2.60)	661 (2.55)	500 (3.08)
 WOOD SCREW XL #10-14x1", 1 ¹ / ₂ "		901 (2.59)	728 (2.73)	563 (2.63)	492 (2.67)	426 (2.77)
 LOW PROFILE WOOD SCREW #12-11 x1 ¹ / ₂ "						
 PANCAKE HEAD DRILLER #10-16x1"			1263 (2.55)	870 (2.63)	654 (2.71)	
 SELF DRILLER NO WASHER 1/4"-14x1 ¹ / ₂ "						
 SHOULDER SELF DRILLER 1/4"-14x1 ¹ / ₄ "						
 SELF DRILLER NO WASHER #12-14x1", 1 ¹ / ₂ "	751 (2.74)		1357 (2.61)	918 (2.60)	667 (2.63)	524 (2.95)
 SELF DRILLER XL #12-14x1", 1 ¹ / ₄ ", 1 ¹ / ₂ "						
 STITCH XL 1/4"-14x ⁷ / ₈ "						
 DECK SCREW #14-13x2", 4", 5", 6", 8"						

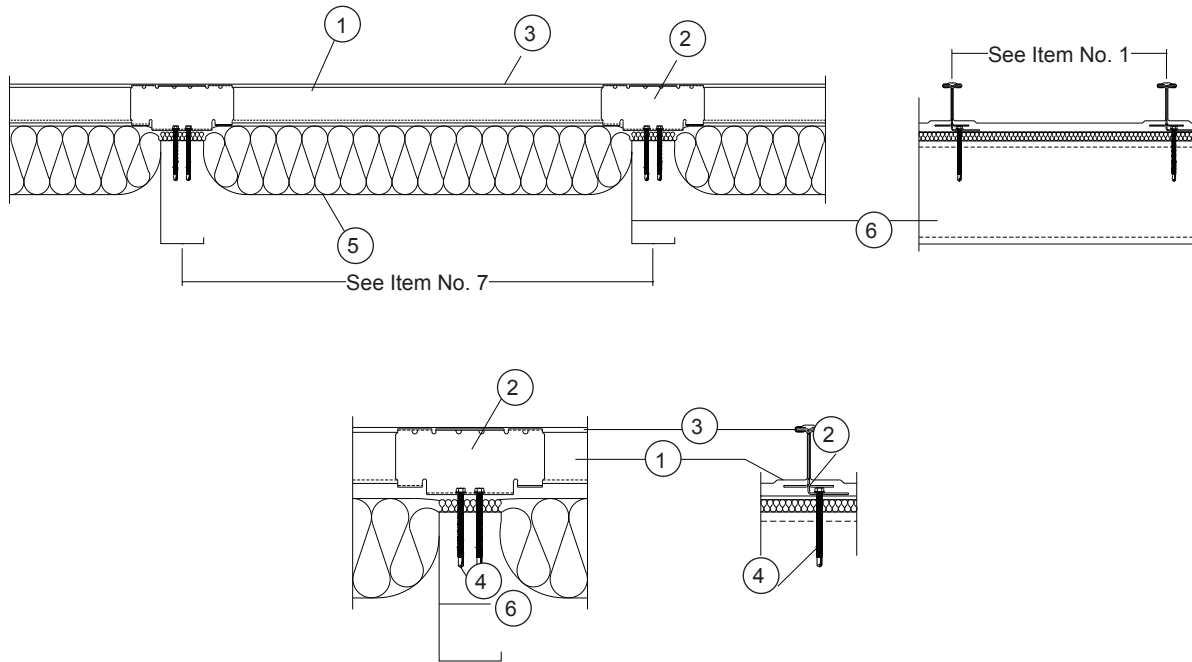

T-ARMOR

Construction No. 268
 July 15, 2013
 Uplift - Class 90
 Fire Not Investigated

1. **Metal Roof Deck Panels*** - No. 24 MSG min thick coated steel or stainless steel or min .030 thick aluminum; nom 18 in. wide, 2-3/8 in. high standing seams. Panels continuous over two or more spans. Floating end laps to occur over purlins with panels overlapped 8 in. End lap to begin 3 in. from purlin web and to extend across purlin flange. A bead of mastic sealant may be used at panel end and side laps.
2. **Panel Clips*** - No. 16 MSG min gauge coated steel or stainless steel, 6 in. long by 2.718 in. high. Base to have four .281 in. dia. guide holes to accommodate screw fasteners (Item 4)
3. **Cap** - Used at seam, nom 1 in. wide, 1/2 in. deep fabricated from min No. 24 MSG gauge steel, stainless steel, or .030 in. thick aluminum. Cap continuously seamed over panel seams using an electric seaming tool. Seaming process to include panel clips (Item 2).
4. **Fasteners** - (Screws) - Fasteners used to attach panel clips to purlin to be No. 14 by 3 in. long self tapping, hex-head, plated or stainless steel screws without washers or 1/4 in - 14 hex head driller without washer. Two fasteners per clip to be used. Fasteners used to attach thermal spacer (Item 6) to purlins to be same type, spaced 18 in. OC. Fastener used at end lap to be an expanding bolt type with an aluminum sleeve having a 5/8 in. diam cap with a 1/4 - 20 by 1-7/16 in. long stainless steel bolt. Spacing at end lap to be 1, 3, 3, 4, 3, 3, 1, in. pattern.
5. **Insulation** - (Optional) - Any compressible blanket insulation, 6 in. max thick before compression, or foamed plastic (rigid insulation) supplied in min thickness 1 in., max thickness 4 in.
6. **Purlins** - No. 16 MSG min steel (50,000 psi min yield strength).

Spacing	60 in. OC for steel panels - Class 90
	48 in. OC for aluminum panels - Class 90

7. **Lateral Bracing** - (Not Shown) - As required.

***Bearing the UL Classification Mark**



Underwriters Laboratories Inc.®
 LISTED

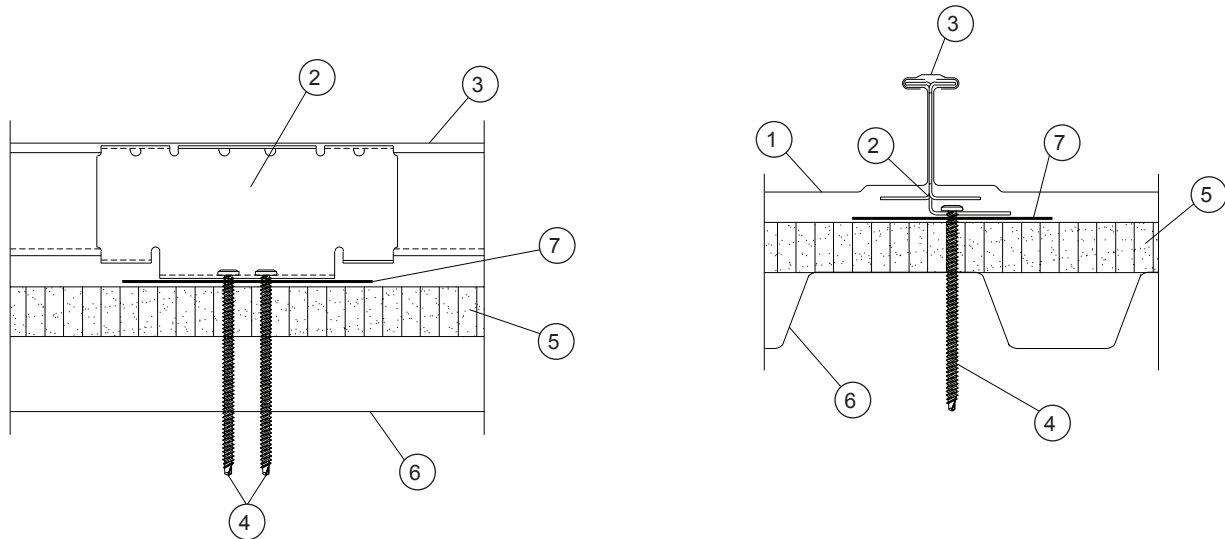

T-ARMOR

Construction No. 268A

July 15, 2013

Uplift - Class 90

Fire Not Investigated

1. **Metal Roof Deck Panels*** - No. 24 MSG steel or stainless steel or 0.030 in. thick aluminum, nom 18 in. wide, 2-3/8 in. high standing seams. Heavier gauges or narrower panels acceptable. Panels continuous over two or more spans. Floating end laps to occur over purlins with panels overlapped 8 in. End lap to begin 3 in. from purlin web and to extend across purlin flange. A bead of mastic sealant may be used at panel end and side laps.
2. **Panel Clips*** - No. 16 MSG min gauge coated steel or stainless steel, 6 in. long by 2.718 in. high. Base to have four .281 in. dia. guide holes to accommodate screw fasteners (Item 4). Clips spaced 48" on center maximum, fastened through metal decking.
3. **Cap** - Used at seam, nom 1 in. wide, 1/2 in. deep fabricated from min No. 24 MSG steel, stainless steel or 0.030 in. thick aluminum. Cap continuously seamed over panel seams with a special motorized seaming tool. Seaming process to include panel clips (Item 2)
4. **Fasteners - (Screws)** - Fasteners used to attach panel clips (Item 2) to liner panel to be No. 12 self-tapping, hex-head, plated or stainless steel screw without washers or #14-13 with No. 3 phillips head Deck Screw. Two fasteners per clip to be used. Fasteners used to attach thermal spacer (Item 9) to purlins to be same type spaced 18 in. OC. Fasteners used at end lap to be expanding bolt type with an aluminum sleeve having a 5/8 in. diam cap with a 1/4-20 by 1-7/16 in. long stainless steel bolt. Spacing at end lap to be 1, 3, 3, 4, 3, 3 in. pattern. Length to depend on thickness of insulation and/or thermal spacers and to be 3/4 in. longer than overall depth of deck assembly.
5. **Foamed Plastic** - (Optional) - Extruded foamed plastic (rigid Insulation) min density 2.00 pcf supplied in min thickness 1 in., max thickness 4 in.
6. **Liner Panel** - Fabricated from No. 22 MSG min thickness coated steel. Min depth 15/16 in., max pitch 7.2 in., min yield strength 33 ksi. or 18/20 MSG thickness (No 22 MSG min) coated steel, 4-1/2 in. deep, (24 in. coverage), min yield strength 33 ksi. Max span of panel units to be per manufacturer's instructions. Panels attached to structural supports with screws or welds per liner panel manufacturer's instructions.
7. **Bearing Plate** - (Optional) - No. 22 MSG steel, 6 in. by 6 in. Used with rigid insulation only.
8. **Supports (Purlins)** - (Not Shown) - Purlins used for liner panels to be cold formed steel sections. As alternates, structural steel components (hot rolled beams, channels, open web joist etc.) may be used. Min gauge and yield to depend on design considerations. Max spacing to depend on design considerations.
9. **Thermal Spacer** - (Optional) - (Not Shown) - Located over liner panel at panel clip locations. Continuous nom wood 2 in. by 4 in. Not used when foamed plastic (Item 5) is used.

Refer to General Information, Roof Deck Construction (Roofing Materials and Systems Directory) for items not evaluated.

10. **Plywood or OSB** - (Optional) (Not Shown) - Min APA rated plywood, nom 1/2 in. thick or oriented strand board (OSB), nom 7/16 in. thick, 4 x 8 ft. Sheets to be installed on top of Foamed Plastic (Item 5) in lieu of bearing plates (Item 7)

*Bearing the UL Classification Mark



Underwriters Laboratories Inc. ®
LISTED

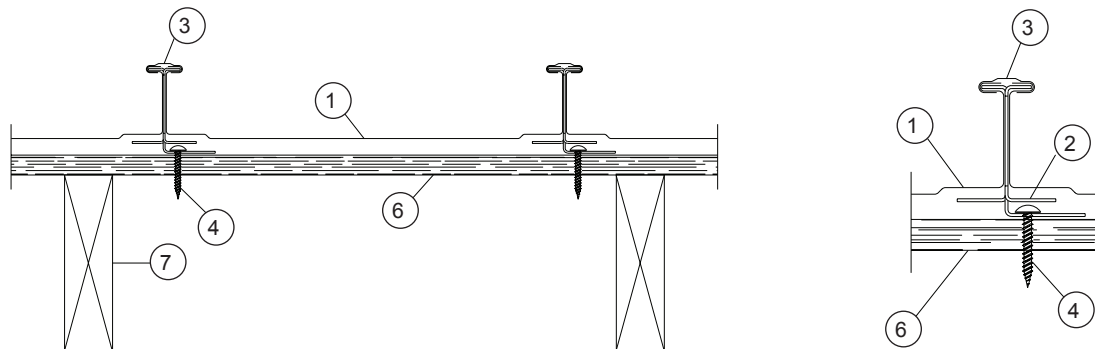

T-ARMOR

Construction No. 268B

July 15, 2013

Uplift - Class 90

Fire Not Investigated

1. **Metal Roof Deck Panels*** - Min No. 24 MSG gauge steel or stainless steel or 0.030 in. thick aluminum, nom 18 in. wide, 2-3/8 in. high standing seams. Heavier gauges or narrower panels acceptable. Panels continuous over three or more clips with no end laps.
2. **Panel Clips*** - No. 16 MSG min gauge coated steel or stainless steel, 6 in. long by 2.718 in. high. Base to have four .281 in. dia. guide holes to accommodate screw fasteners (Item 4). Clips spaced 24" on center maximum, fastened through plywood decking.
3. **Cap** - Used at seam, nom 1 in. wide, 1/2 in. deep fabricated from min No. 24 MSG gauge steel, stainless steel, or .030 in. thick aluminum. Cap continuously seamed over panel seams using an electric seaming tool. Seaming process to include panel clips (Item 2).
4. **Fasteners - (Screws)** - Fasteners used to attach panel clips to plywood deck to be No. 12-11 Low profile, No.3 Square drive wood screw. Two fasteners per clip to be used.
5. **Underlayment** - (Optional) - (Not Shown) Underlayment used over plywood deck to be type 15 or 30 organic felt. Sides overlapped min 2 in., end laps per manufacturer's instructions. Felt nailed to plywood deck with 1-1/4 in. long steel cap nails, located per manufacturer's instructions. Nail spacing to be max 12 in. OC at the side lap and max 24 in. OC in interior rows. **As An Alternate** - A self-adhering modified bitumen water proofing membrane may be used, installed per manufacturer's instructions. Note - when alternate is used the plywood joints need not be sealed.
6. **Plywood Decking** - Plywood decking to be graded per PS83 specifications, 19/32 in. thick, exposure 1, APA Rated Sheathing (42/20) square edged. Butt ends not blocked. All butt and side joints to be sealed against leakage by using tape and/or caulk. (Note exception under Item 5, Alternate).
7. **Supports** - Spaced max of 24 in OC. Any of the following types may be used to support the plywood decking.
 - a) Nom 2 by 6 in., No. 2 grade or better S-P-F, Hemlock Fir, Douglas Fir or Southern Yellow Pine or equivalent.
 - b) Wood trusses with a nom 2 by 4 in. upper chord of the grade as item a.
 - c) No. 22 MSG min cold formed coated steel (min yield to be 33 ksi)
8. **Plywood Fasteners** - (Not Shown) - Fasteners used to attach the plywood deck to the supports to be as follows:
 - a) For plywood-to-wood supports No. 8-18 by 1-7/8 in. long bugle-head steel screw with a No. 2 Phillips drive, a "Hi-Low" thread pattern and an "S-Point".
 - b) As an alternate to Item a, 8d common nails may be used.
 - c) For plywood-to-steel supports for a steel thickness less than No. 20 MSG No. 7-19 by 1-1/4 in. long bugle-head steel screw with a No. 2 Phillips drive, a "Hi-Low" thread pattern and an "S-Point". For a steel thickness greater than No. 20 MSG to No. 16 MSG, No. 6-20 by 1-1/4 in. long bugle-head steel screws with a No. 2 phillips drive and a S12 (TekS/3)supR point.

Spacing: Fasteners spacing for all fasteners types to be 6 in OC at the plywood edges and 12 in. OC in the interior.

Refer to General Information, Roof Deck Construction (Roofing Materials and Systems Directory) for items not evaluated.

*Bearing the UL Classification Mark



Underwriters Laboratories Inc. ®
LISTED

T-ARMOR

UL 263 FIRE RESISTANCE RATINGS

Metal Roof Deck Panels

Metal Sales Manufacturing Corporation has obtained fire resistance ratings for various products conducted according to test criteria set forth by 'Underwriters Laboratories' "Standard Fire Tests of Building Construction and Material" (ANSI/UL 263). This test procedure is identical to ASTM E-119 and NFPA 251.

The fire resistance rating is for the total assembly and not just the external metal panel. Ratings are expressed in hours and vary depending upon the assemblies.

In general, the test criteria is to evaluate the assembly's ability to continue to support the superimposed loads and resist the passage of flame, high temperatures, or hot gases which will ignite combustible materials. The test assemblies are identified by an alpha-numeric design number.

For detail information on specific assemblies and hourly ratings see UL Fire Resistance Directory.



Underwriters Laboratories Inc. ®
LISTED

T-ARMOR

TESTING SUMMARY

Category	Test Protocol	Description
Fire	UL 790	Class A roof covering over noncombustible deck or framing ot with fire barrier over combustible materials
	ASTM E 84	Flame Spread
Structural	UL 580	Class 90 uplift roofs over steel purlins, 5/8" plywood or 22 ga steel deck
	ASTM E 1592	Uplift load resistance for a range of thicknesses, widths and heights
	ASTM E 1592	Gravity load resistance
	ASTM E 330	Load resistance
Water Penetration	TAS 100	Wind Driven Rain, specimen subject to 110 mph wind with 8.8 inches/hour water spray with no leaks
	AAMA 501.1	Water penetration under dynamic prssure
	ASTM E 1646	Water penetration of exterior metal roof panel system
	ASTM E 331	Water penetration of exterior curtain wall
	ASTM E 2140	Standing Water Test
Air Leakage	ASTM E 1680	Air leakage through exterior metal roof panel system
	ASTM E 283	Air leakage through exterior curtian wall
Thermal Movement	Cyclic Movement	Clips and seam progressed through 100,000 two inch movement cycles
Impact	ICC 500	Large missile impact
	FEMA 361	Large missle impact
	ASTM E 1996	Large missle impact with cyclic wind pressure testing
	ASTM E 1886	Large missle impact with cyclic wind pressure testing
	TAS 201, 203	Large missle impact with cyclic wind pressure testing

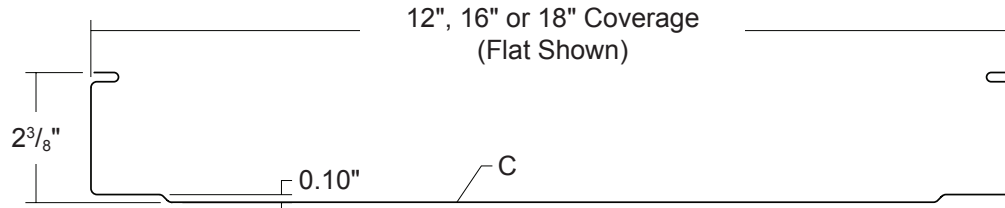

STEEL SECTION PROPERTIES

**ALLOWABLE UNIFORM LOADS psf
(3 or More Equal Spans)**

Thick ga	Width in	Yield ksi	Weight psf	Top In Compression		Bottom In Compression		Inward Load						Outward Load					
				Ixx in ⁴ /ft	Sxx in ³ /ft	Ixx in ⁴ /ft	Sxx in ³ /ft	2'	2.5'	3'	3.5'	4'	5'	2'	2.5'	3'	3.5'	4'	5'
24	12	50	1.50	0.3398	0.2053	0.2078	0.1758	400	400	362	280	222	149	119	108	96	85	73	50
22	12	50	1.97	0.4640	0.2806	0.3020	0.2466	400	400	400	400	326	216	119	108	98	87	76	55
24	16	50	1.35	0.2828	0.1601	0.1260	0.0944	400	295	215	163	127	84	88	80	73	66	59	44
22	16	50	1.78	0.3810	0.2157	0.1800	0.1397	400	400	328	247	192	126	109	100	91	82	73	55
24	18	50	1.30	0.2567	0.1419	0.1113	0.0836	377	261	190	144	113	74	68	62	56	50	44	32
22	18	50	1.71	0.3507	0.1932	0.1600	0.1242	400	400	292	220	171	112	87	80	74	67	61	47

1. Section properties and allowable loads are calculated per AISI 2016.
2. Ixx and Sxx are effective section properties for deflection and bending.
3. Allowable loads are calculated considering bending, shear, combined bending and shear, deflection and ASTM E 1592 uplift load testing on 16 ga purlins. Allowable loads consider the 3 or more equal spans condition.
4. Allowable loads do not include a 1/3 stress increase.

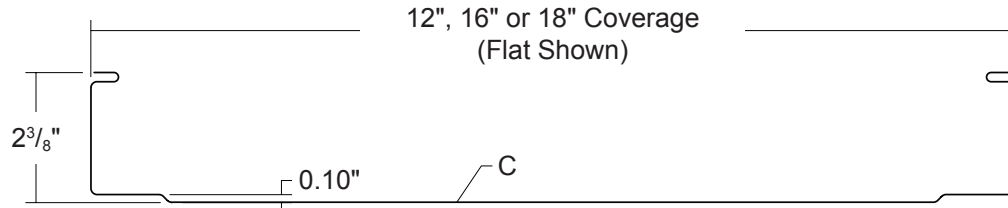

ALUMINUM SECTION PROPERTIES							ALLOWABLE UNIFORM LOADS psf (3 or More Equal Spans)											
Thick in	Width in	Yield ksi	Weight psf	I in ⁴ /ft	S _{TOP} in ³ /ft	S _{BOT} in ³ /ft												
							2'	2.5'	3'	3.5'	4'	5'	2'	2.5'	3'	3.5'	4'	5'
0.032	12	17	0.73	0.5110	0.3093	0.7391	144	94	65	48	31	24	121	109	98	87	75	53
0.032	16	17	0.65	0.4200	0.2378	0.7261	106	69	48	35	27	18	93	84	76	67	59	42
0.032	18	17	0.63	0.3867	0.2129	0.7222	93	61	42	31	24	15	82	74	67	59	51	35

1. Section properties and allowable loads are calculated per Aluminum Design Manual, 2015 Edition.
2. Allowable loads are calculated considering bending, shear, combined bending and shear, deflection and ASTM E 1592 uplift load testing on 16 ga purlions. Allowable loads consider the 3 or more equal spans condition.
3. Allowable loads do not include a 1/3 stress increase in uplift.

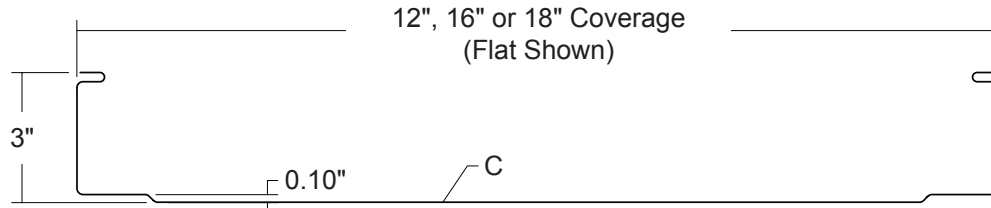

STEEL SECTION PROPERTIES

**ALLOWABLE UNIFORM LOADS psf
(3 or More Equal Spans)**

Thick ga	Width in	Yield ksi	Weight psf	Top In Compression		Bottom In Compression		Inward Load						Outward Load					
				Ixx in ⁴ /ft	Sxx in ³ /ft	Ixx in ⁴ /ft	Sxx in ³ /ft	2'	2.5'	3'	3.5'	4'	5'	2'	2.5'	3'	3.5'	4'	5'
24	12	50	1.60	0.5756	0.2723	0.3676	0.2442	400	400	379	305	251	178	51	47	44	41	37	31
22	12	50	2.10	0.7900	0.3776	0.5290	0.3434	400	400	400	400	400	284	51	47	44	41	37	31
24	16	50	1.43	0.4665	0.2063	0.2235	0.1328	400	323	247	194	157	107	51	47	44	41	37	31
22	16	50	1.87	0.6428	0.2869	0.3195	0.1964	400	400	400	325	256	170	51	47	44	41	37	31
24	18	50	1.37	0.4260	0.1839	0.1987	0.1177	400	287	219	173	139	95	51	47	44	41	37	31
22	18	50	1.80	0.5887	0.2560	0.2840	0.1743	400	400	376	288	228	151	51	47	44	41	37	31

1. Section properties and allowable loads are calculated per AISI 2016.
2. Ixx and Sxx are effective section properties for deflection and bending.
3. Allowable loads are calculated considering bending, shear, combined bending and shear, deflection and ASTM E 1592 uplift load testing on 16 ga purlins. Allowable loads consider the 3 or more equal spans condition.
4. Allowable loads do not include a 1/3 stress increase.

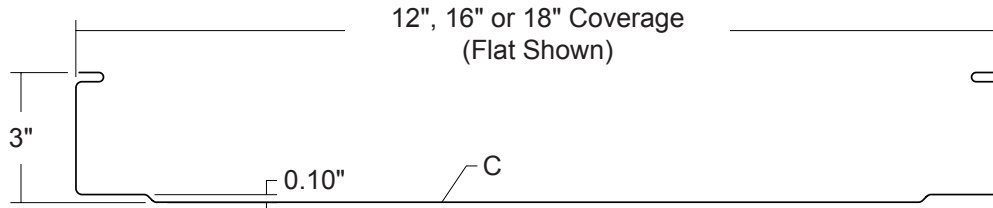

ALUMINUM SECTION PROPERTIES							ALLOWABLE UNIFORM LOADS psf (3 or More Equal Spans)											
Thick in	Width in	Yield ksi	Weight psf	I in ⁴ /ft	S _{TOP} in ³ /ft	S _{BOT} in ³ /ft												
							2'	2.5'	3'	3.5'	4'	5'	2'	2.5'	3'	3.5'	4'	5'
0.032	12	17	0.77	0.8880	0.4313	0.9734	187	122	85	63	49	31	55	51	46	42	37	28
0.032	16	17	0.69	0.7313	0.3319	0.9503	136	89	62	46	35	23	55	51	46	42	37	28
0.032	18	17	0.66	0.6727	0.2977	0.9420	120	78	55	41	31	20	55	51	46	42	37	28

1. Section properties and allowable loads are calculated per Aluminum Design Manual, 2015 Edition.
2. Allowable loads are calculated considering bending, shear, combined bending and shear, deflection and ASTM E 1592 uplift load testing on 16 ga purlions. Allowable loads consider the 3 or more equal spans condition.
3. Allowable loads do not include a 1/3 stress increase in uplift.

RECEIVING MATERIAL

It is the responsibility of the installer to unload material from the delivery truck. The installer shall be responsible for providing suitable equipment for unloading of material from the truck.

After receiving material, check the condition of the material, and review the shipment against the shipping list to ensure all materials are accounted for. If damages or shortages are discovered, it should be noted on the Bill of Lading at the time of delivery. A claim should be made against the carrier as soon as possible. Metal Sales is not responsible for any damages or shortages unless they are documented in writing and presented to Metal Sales within 48 hours.

GENERAL HANDLING

Each bundle should be handled carefully to avoid being damaged. Care should be taken to prevent bending of the panel or abrasion to finish. Whenever possible, the bundle should remain crated until it is located in its place of storage. If bundles must be opened, we recommend recrating them before lifting. To avoid damage, please lift the bundle at its center of gravity.

CAUTION

Improper loading and unloading of bundles and crates may result in bodily harm and/or material damage. Metal Sales is not responsible for bodily injuries and/or material damages resulting from improper loading and unloading.

MECHANICAL HANDLING

Forklift - A forklift may be used for panels up to 20'-0" long. Please make sure the forks are at their maximum separation. Do not transport open bundles. When transporting bundles across rough terrain, or over a longer distance, some means of supporting the panel load must be used.

Crane - A crane should be used when lifting panels with lengths greater than 20'-0". Please be sure to utilize a spreader bar to ensure the even distribution of the weight to the pick up points. As a rule when lifting panels, no more than $\frac{1}{3}$ of the length of the panel should be left unsupported. Never use wire rope because this will damage the panels.

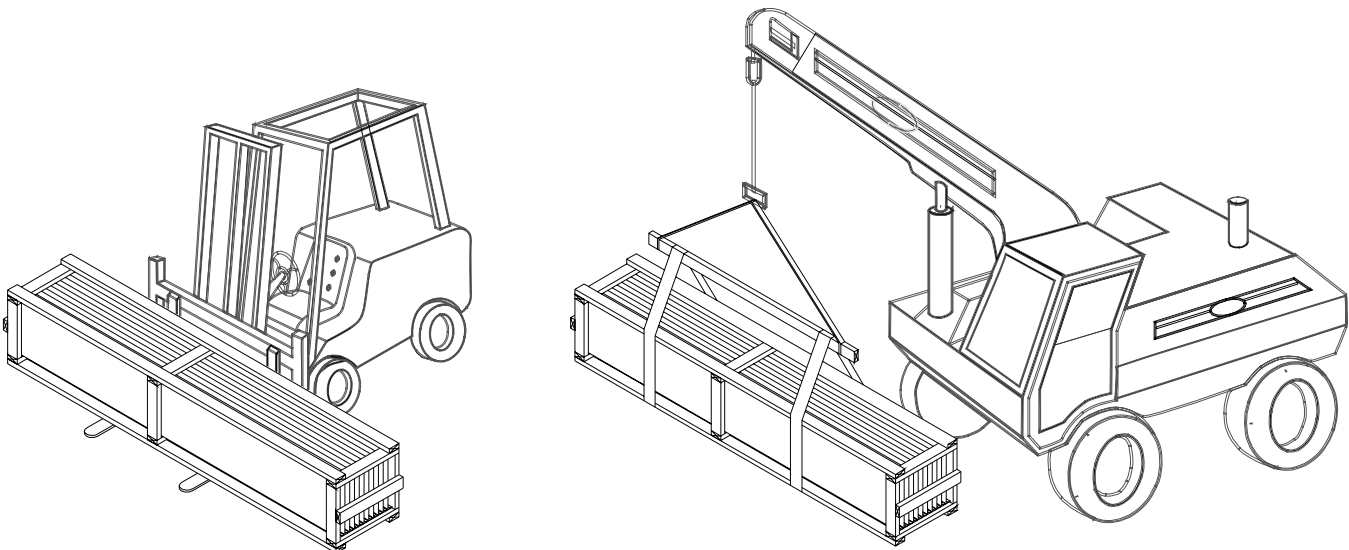

MANUAL HANDLING

When handling painted steel care should be taken to prevent scratching of material. Clean gloves should be worn at all times to prevent a reaction with salts found on bare skin. Installers should wear rubber sole shoes to keep from scuffing material while walking on the roof.

Handling of individual panels should be done carefully and properly to avoid bending or damaging. T-Armor panels should be carried by grasping the edge of the panel so that the T-Armor panel is vertical to the ground. The T-Armor panel should not be carried with the panel horizontal to the ground as this could cause the panel to buckle or bend in the center.

Normally individual panels can be handled by people placed every 6'-0" to 8'-0" along the length of the panel.

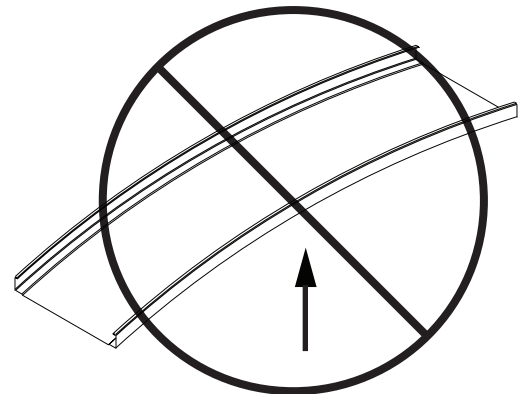
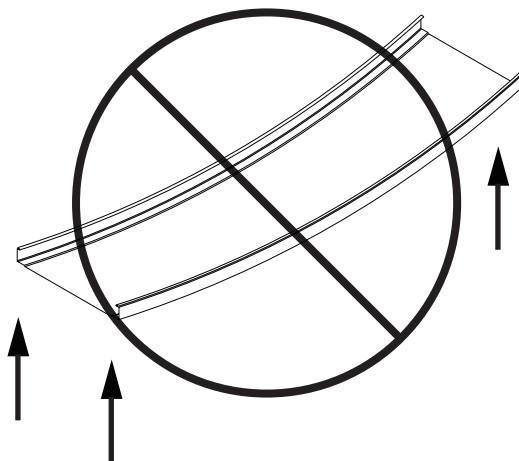
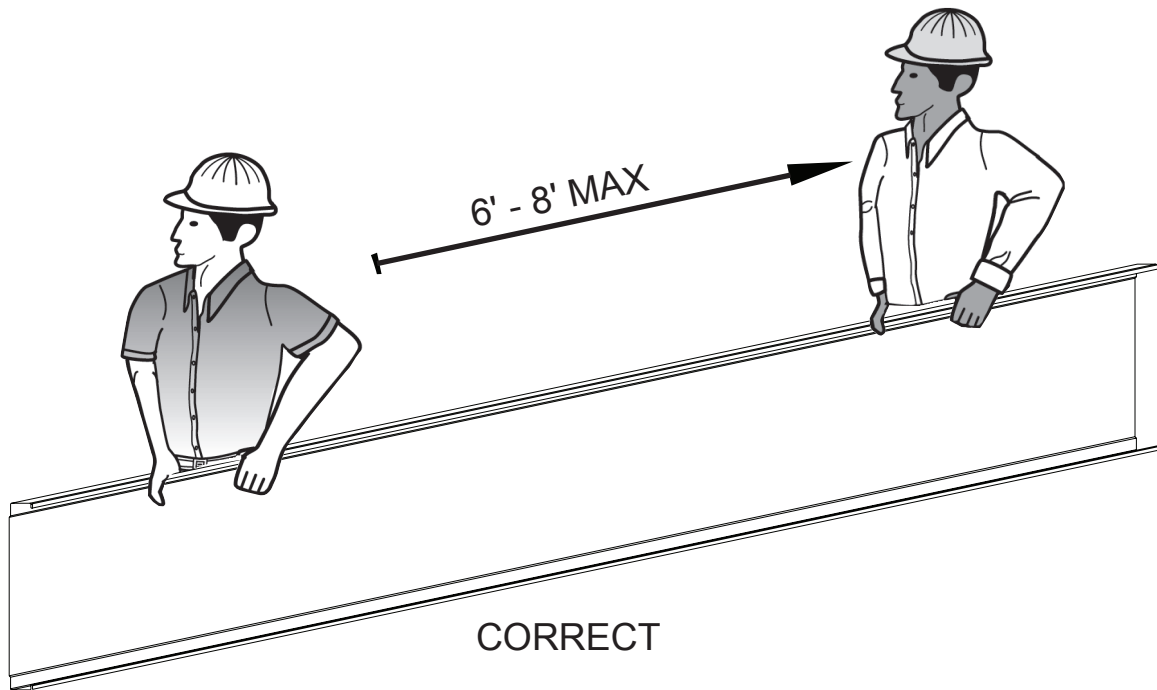

GENERAL

Please inspect panels for moisture accumulation. If moisture has formed, the panels should be unbundled, wiped dry, and allowed to dry completely. Once dry, carefully restack the panels and loosely recover allowing for ample air circulation.

Bundled sheets should be stored high enough off of the ground to allow for air circulation and prevent contact with accumulating water. If possible, elevate one end of the bundle to allow any moisture to run off the panels. Metal Sales recommends covering the bundle with a tarp. Do not use tight fitting plastic-type tarp as panel bundle covers. While they may provide protection from heavy downpours, they can also retard necessary ventilation and trap heat and moisture that may accelerate metal corrosion. If panels are to be stored in possible bad weather, we suggest they be stored inside. Extended storage of panels in a bundle is not recommended. **Under no circumstances should the sheets be stored near or come in contact with salt water, corrosive chemicals, ash, or fumes generated or released inside the building or nearby plants, foundries, plating works, kilns, fertilizer, and wet, green treated lumber.**

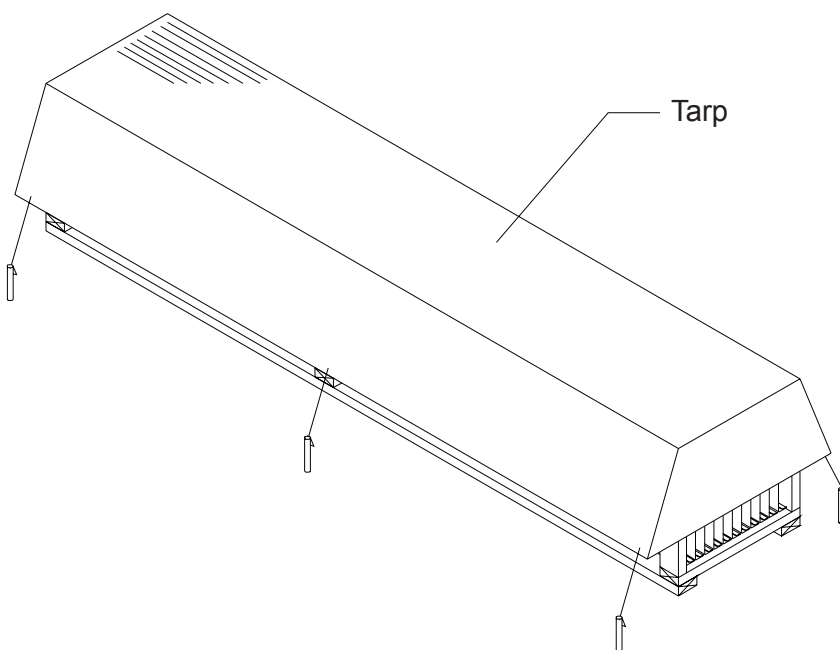
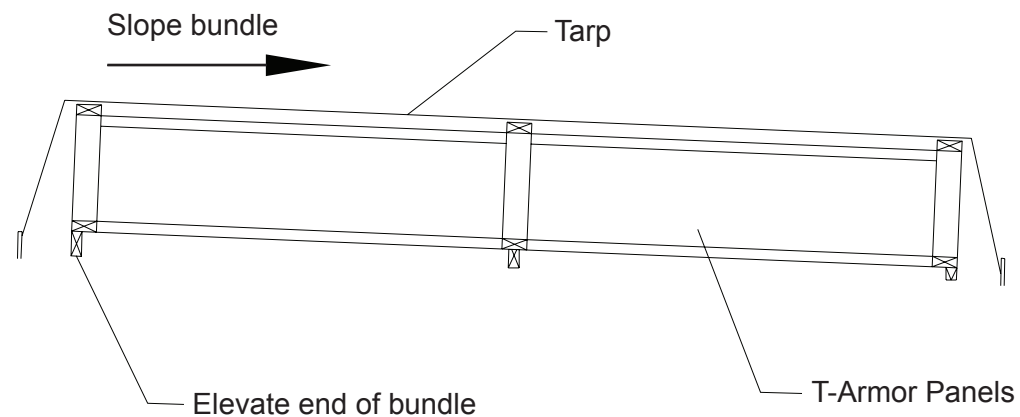

STORAGE ON ROOF

To facilitate the handling of T-Armor panels, panel bundles can be lifted and placed on the roof. Bundles need to be placed on the roof in order for the roof structure to handle the weight. Loading capabilities of the structure must be checked.

When lifting packaged sheets, make certain they are adequately supported. Panels less than 20'-0" in length can normally be lifted with a forklift; however, when lifting panels in excess of 20'-0", it is recommended that a spreader bar and slings be used. As a rule, when lifting, no more than $\frac{1}{3}$ of the length of the panel can be left unsupported.

Make a plan for bundle placement by determining how much area a bundle of panels will cover. Bundles should be placed on the roof in accordance with the direction the panel will be installed. Consider where the string line, if any, is to run at the eave to set roof panels by. Roof bundles should not interfere with this string line.

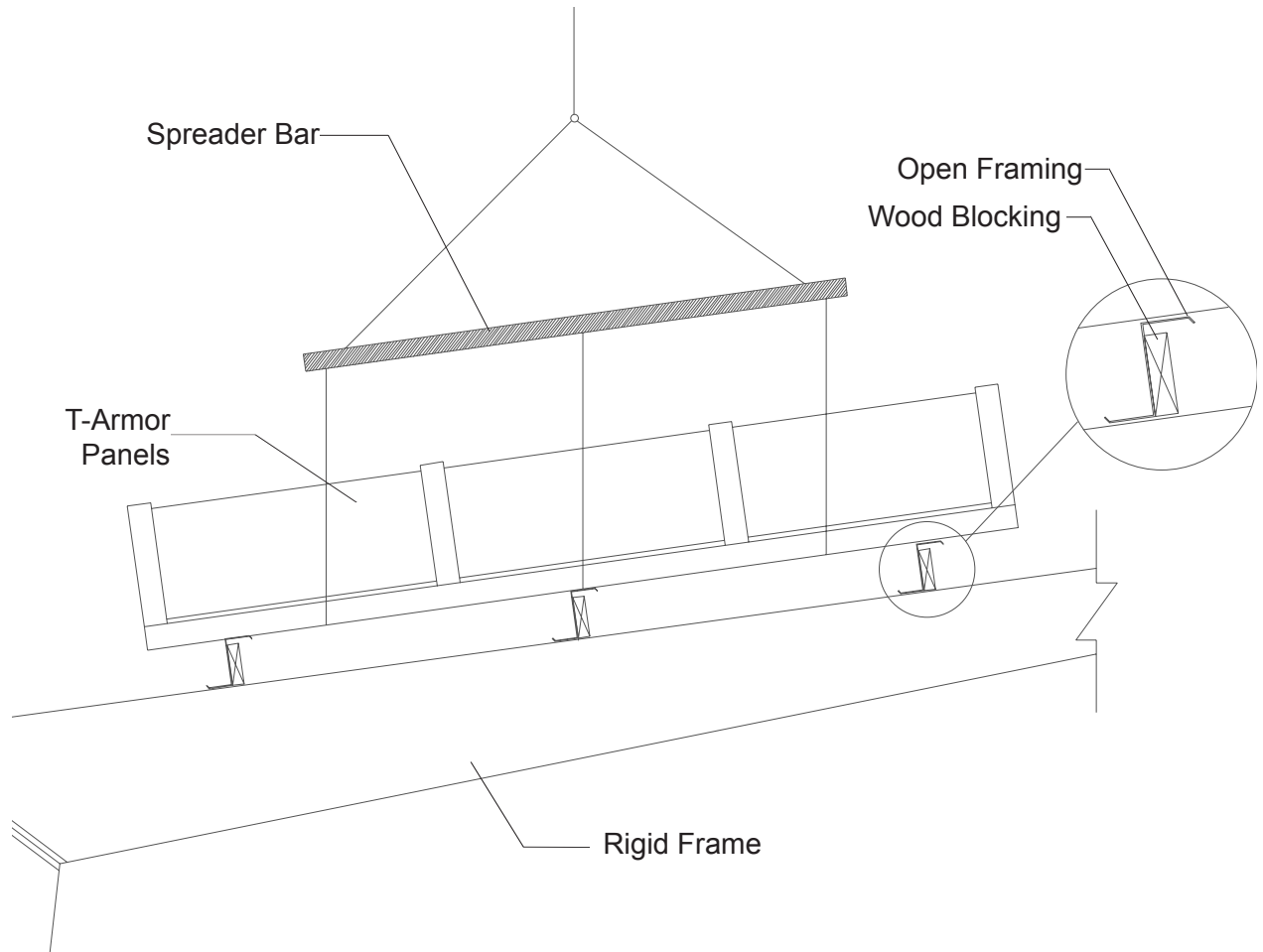

INSTALL CONCERNS

- Remove stripable film before significant exposure to sunlight.
- Do not mark on Acrylic Coated Galvalume (ACG) with a penil - use felt marker.
- Do not leave ms-HT underlayment exposed for extended period.
- Do not install copper or lead on the roof.
- Remove burrs from exposed fasteners.
- Keep panels and trims clean.
- Do not cut metal on the roof with a curcular saw.
- Do not install panels directly over metal supports, include insulation to reduce noise.

Care of metal panels and flashings must be exercised throughout erection. Foot traffic can cause distortion of panel and damage to finish. Traffic over the installed system must be kept to an absolute minimum. If continuous foot traffic is necessary for maintenance over certain areas of the roof, then a permanent walkway should be installed.

When walking on the roof panels is unavoidable, walk only in the flats of the panel. Walking on the ribs can cause damage to the panels. If T-Armor is installed over open framing, step in the flat of the panel only and as close to the framing as possible.

OVER OPEN FRAMING

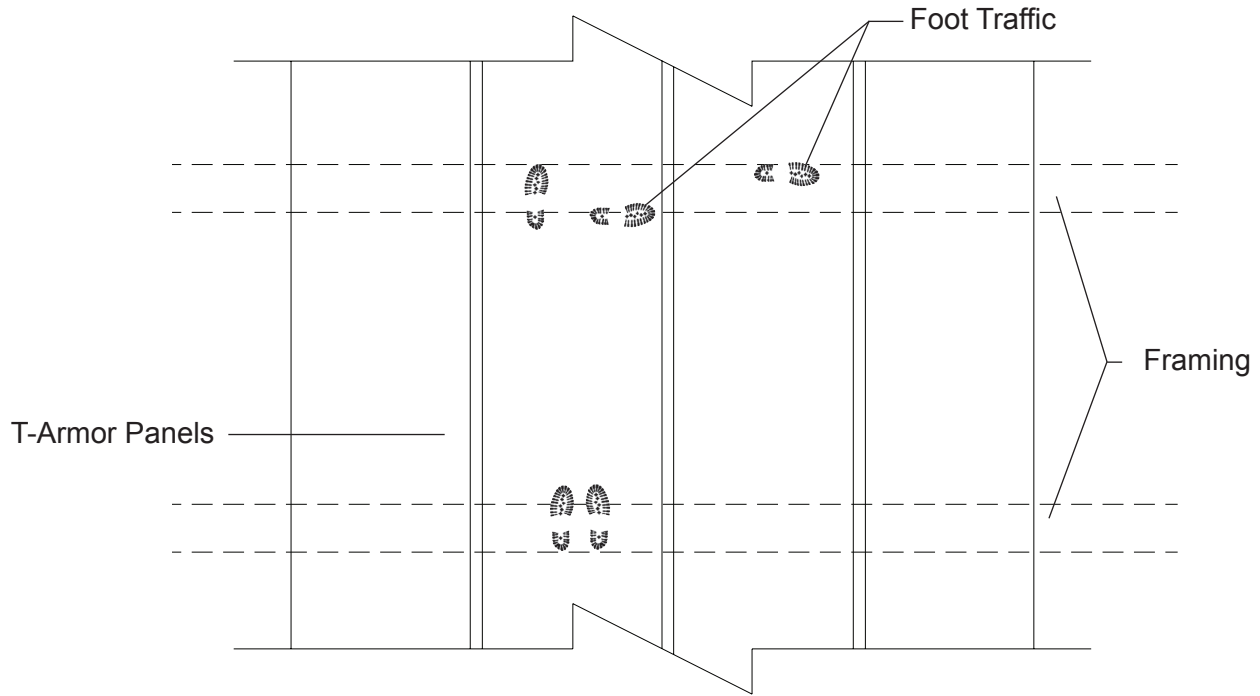

CURB INSTALLATION

Size and location of all roof penetrations should be an important consideration. Areas around roof vents or rooftop units may show that corrosive fumes are emitted from a process within the building.

Curbs can be obtained from any of the following manufacturers:

KCC International, Inc.	(800)382-2872	Custom Curb	(800)251-3001
ThyCurb	(800)666-2872	LM Curbs	(800)284-1412
Curbs Plus, Inc.	(888)639-2872	FastCurbs	(877)728-3278

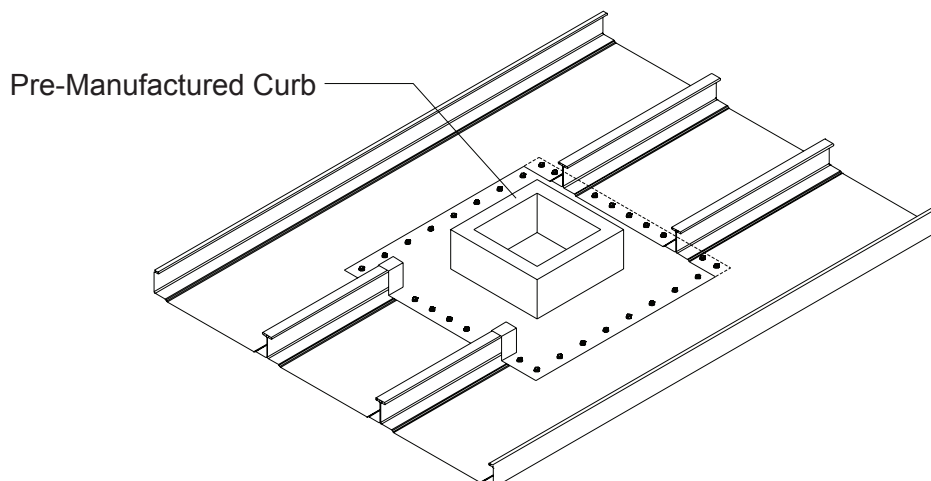

FIELD-CUTTING

Tin snips or a "nibbler" type electric tool are recommended for field cutting T-Armor panels. Cutting the metal generates slivers or metal chips. These slivers and metal chips must be immediately removed from the T-Armor panels because they will damage the finish and shorten the life of the product.

One method of preventing this problem is to turn the T-Armor panels over before cutting. This allows the slivers and metal chips to be brushed from the back side and avoids damaging the paint on the top side of the panels.

When cutting T-Armor panels, goggles must be worn for eye protection.

CAUTION

All product surfaces should be free of debris at all times. Installed surfaces should be wiped clean at the end of each work period. Never cut panels over metal surfaces. Metal shavings will rust on the surface, voiding the warranty.

TOUCH-UP PAINT

All painted panels and flashings have a factory-applied baked-on finish. Handling and installing panels may result in some small scratches or nicks to the paint finish. Touch-up paint is available in matching colors from Metal Sales. It is recommended that a small brush be used to apply touch-up paint to those areas that are in need of repair. Touch-up paint does not have the superior chalk and fade resistance of the factory applied paint finish and will normally discolor at an accelerated rate. Aerosol paint should not be used because of the overspray that may occur.



SPRAY PAINT

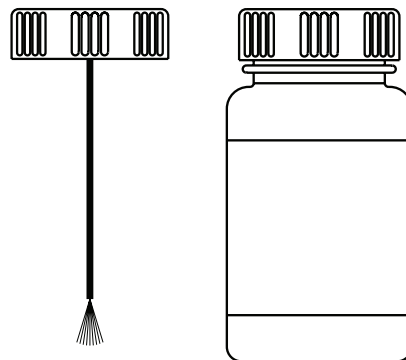

TOUCH-UP PAINT

FASTENER INSTALLATION TECHNIQUE

Recommended Tool Type - Use depth locating nose or adjustable clutch on screw gun to prevent overdrilling and strip out. **Do not use impact tools or runners.**

Seating the washer - Apply sufficient torque to seat the washer - do not overdrive the fastener.

	CORRECT Sealing material slightly visible at edge of metal washer. Assembly is watertight.	TOO LOOSE Sealing material is not visible; not enough compression to seal properly.	TOO TIGHT Metal washer deformed; sealing material pressed beyond washer edge.
SELF DRILLER			
WOODSCREW			

To prevent wobbling - Make sure fastener head is completely engaged in the socket. If the head does not go all the way in the socket - tap the magnet deeper into the socket to allow full head engagement. Metal chips will build up from drilling and should be removed from time to time.

Protect drill point - Push only hard enough on the screw gun to engage clutch. This prevents excess friction and burn out of the drill point. Correct pressure will allow screw to drill and tap without binding.

Drilling through sheet and insulation - Ease up on pressure when drilling through insulation to avoid striking the purlin or girt with the point - apply more pressure after drill point contacts purlin or girt.

Drilling through purlin overlaps - Drilling through lapped purlins requires extra care. Excessive voids between purlins sometimes damages drill points and two self-drillers might be necessary to complete the operation. It is sometimes advantageous to predrill.

CONDITION OF SUBSTRUCTURE

Whether over solid substrate or open structural framing, panel distortion may occur if not applied over properly aligned and uniform substructure.

The installer should check the roof deck for squareness before installing T-Armor panels. Several methods can be used to verify squareness of the structure for proper installation of the panels.

METHOD "A" - One method for checking the roof for squareness is to measure diagonally across one slope of the roof from similar points at the ridge and eave and obtain the same dimension.

METHOD "B" - The 3-4-5 triangle system may also be used. To use this system measure a point from the corner along the edge of the roof at a module of three (3). Measure a point from the same corner along another edge at a module of four (4). Then by measuring diagonally between the two points established, the dimension should be exactly a module of five (5) to have a square corner. Multiple uses of this system may be required to determine building squareness. If the endwall cannot be made square, the roof system cannot be installed as shown in these instructions.

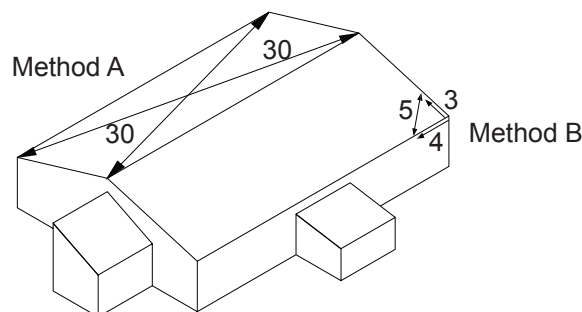

VENTILATION

Proper design and installation of vapor barriers and ventilation systems are important to prevent condensation and the resulting problems of moisture damage and loss of insulation efficiency.

Condensation occurs when moisture-laden air comes in contact with a surface temperature equal to or below the dew point of the air. This phenomenon creates problems that are not unique with metal buildings; these problems are common to all types of construction.

The underside of the metal roof on a typical metal building (no attic) should be protected from condensation by insulating with a faced insulation. This should reduce the potential of condensation forming on the underside of the panels.

On buildings that have an attic space or are being retrofitted with a metal roofing system, vents should be placed at both the eave and peak of the roof in order to prevent a buildup of moisture (humidity) in the attic space.

See ASHRAE Standard 62.2 for guidance on ventilation requirements and design.

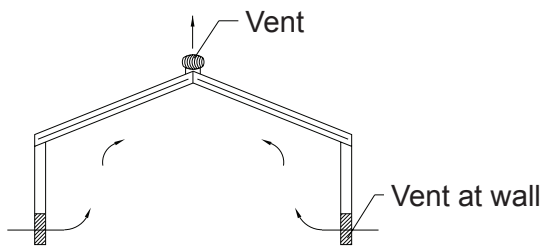

TYPICAL METAL BUILDING (NO ATTIC)

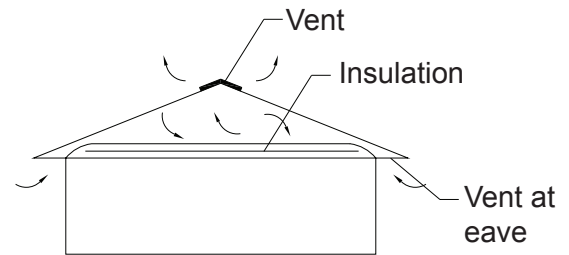

BUILDING WITH ATTIC OR RETROFITTED

INSULATION

In most cases insulation is installed directly under roof panels. Insulation is recommended on all applications to act as a sound barrier, prevent condensation and increase insulating value of a roof system.

Many different types of insulation can be used with the metal roof panels. Blanket, batt, rigid, and reflective insulation are just to name a few. Please contact your insulation supplier for specific recommendations on installation of insulation and vapor barriers.

When applying a compressible type of insulation over open framing members. Rigid thermal blocks can be used to help reduce heat lost at purlin locations.

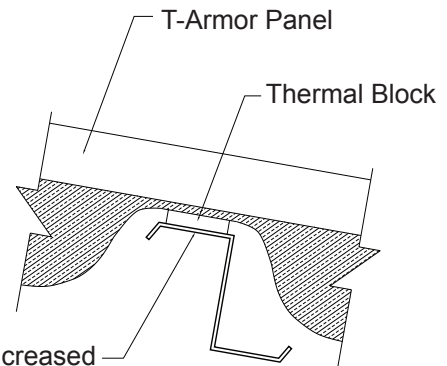
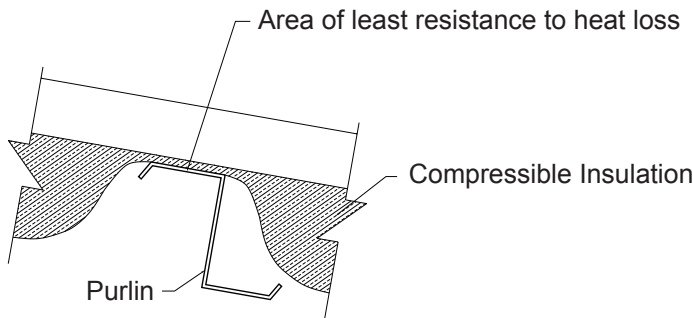

CAUTION

Use extreme care when working next to insulation. The insulation will provide a false sense of security by hiding the view of the ground below

SYSTEM EXPANSION / CONTRACTION

Metal roofing panels are subject to dimensional changes after installation due to exposure to varying temperatures. The greatest influence is solar energy. Steel roofing absorbs various amounts of heat depending upon color, finish, angle of exposure and time of exposure.

The relationship of the roof temperature to building structural temperature must be considered when designing a T-Armor roof system. The clips for the T-Armor panels are designed for expansion and contraction of the panels in the longitudinal direction. Lateral expansion and contraction is accommodated by the configuration of the panel cross section and causes negligible panel movement.

Every panel requires one fixed point to keep the panel in place. Do not install a panel with multiple fixed points. Multiple fixed points will cause the thermal movement to damage the roof system.

SELECTION OF SYSTEM COMPONENTS

The T-Armor roof system can be installed with components that allow the panels to either float independently or fix permanently to the substructure. Choice of system will depend upon building design and regional temperature range (from summer highs to winter lows).

SYSTEM COMPONENTS					
SYSTEM	CLIP	EAVE PLATE	RAKE ANGLE	THERMAL BLOCK	INSULATION
2 ³ / ₈ " UTILITY	2 ³ / ₈ "	1/4" UTILITY	2 ⁵ / ₈ "	NONE REQUIRED	1/2" TO 4" BLANKET
2 ³ / ₈ " LOW	2 ³ / ₄ "	3/8" LOW	2 ⁵ / ₈ "	NONE REQUIRED	4" TO 6" BLANKET
2 ³ / ₈ " HIGH	3 ³ / ₄ "	1 ³ / ₈ " HIGH	3 ³ / ₄ "	1"	4" TO 6" BLANKET
3" UTILITY	3"	1/4" UTILITY	3 ¹ / ₈ "	NONE REQUIRED	1/2" TO 4" BLANKET
3" LOW	3 ³ / ₈ "	3/8" LOW	3 ¹ / ₈ "	NONE REQUIRED	4" TO 6" BLANKET
3" HIGH	4 ³ / ₈ "	1 ³ / ₈ " HIGH	4 ¹ / ₈ "	1"	4" TO 6" BLANKET

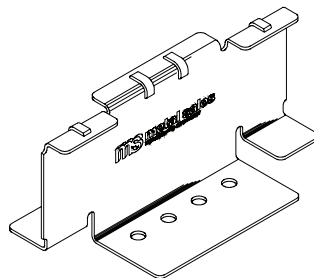

T-Armor Standard Clip

The following chart should be used to determine proper fasteners required for clip installation on the selected applications. (See Fastener Selection Guide page 24 for other fasteners available.)

APPLICATION	INSTALLATION REQUIREMENTS	**CLIP SPACING	TYPE OF FASTENER	NUMBER REQUIRED
CLIPS OVER PURLINS (16 GA. MIN)	STANDARD 24, 22 GA.	5'-0" O.C.	1/4"-14 x 1 1/2" SELF DRILLER N/W	2 FASTENERS
	STANDARD .032" AL	4'-0" O.C.	1/4"-14 x 1 1/2" SELF DRILLER N/W	2 FASTENERS
CLIPS OVER 5/8" WOOD DECK	STANDARD 24, 22 GA.	2'-0" O.C.	#12-11x1 1/2" LOW PROFILE WOOD SCREW	2 FASTENERS
	STANDARD .032" AL	2'-0" O.C.	#12-11x1 1/2" LOW PROFILE WOOD SCREW	2 FASTENERS
CLIP OVER RIGID INSULATION / METAL DECK	STANDARD 24, 22 GA.	4'-0" O.C.	#14-13 DECK SCREW *	2 FASTENERS
	STANDARD .032" AL	4'-0" O.C.	#14-13 DECK SCREW *	2 FASTENERS

* Length of Deck Screw will vary depending on the total thickness of the rigid insulation and metal. (See page 24.)

** Contact your local Metal Sales branch representative for more information. (See pages 2 and 3.)

Factory-Notched Panels - Metal Sales can provide factory-notched panel ends to eliminate material build up or reliance on field-notching for weathertight seams at panel endlaps.

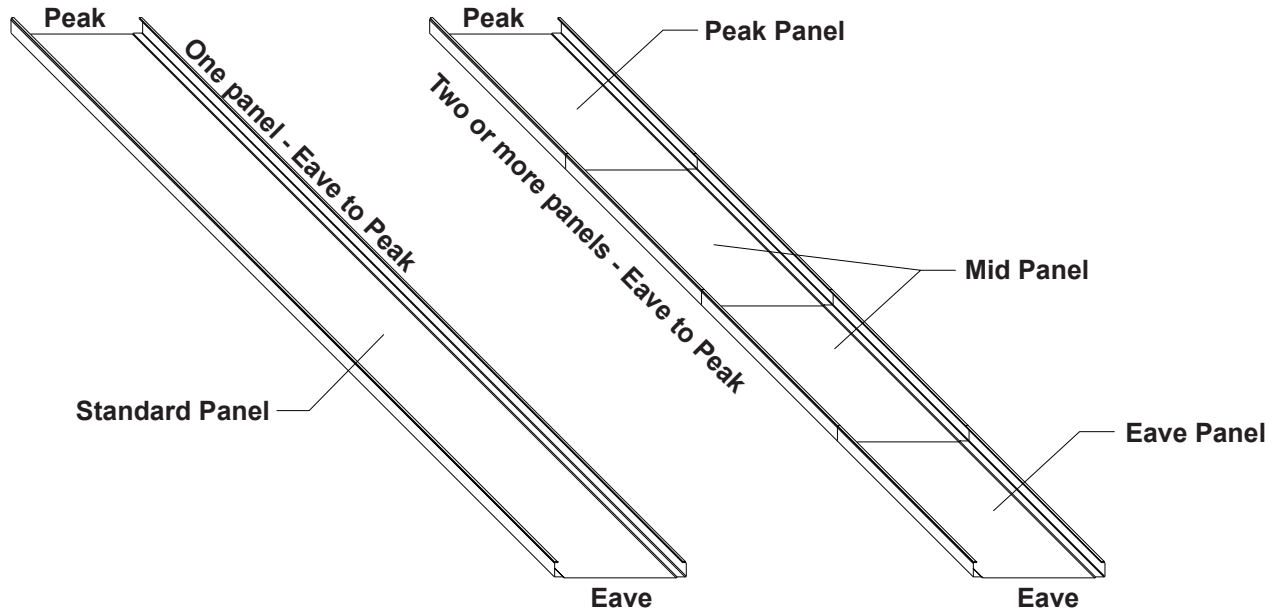

STANDARD PANEL (Not Notched):

- ▶ Used when field-cut panels are required
- ▶ Used as an Eave panel for endlaps
- ▶ One panel from eave to peak of roof
- ▶ No notching
- ▶ 'L' is the Order Length: 80' max length, 6' min length

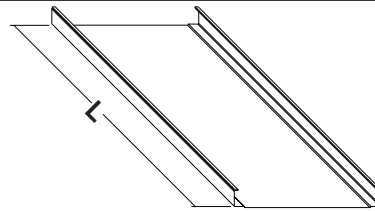

EAVE NOTCHED PANEL:

- ▶ Field-notch panels for hem attachment at eave end of panel
- ▶ Hem attachment accommodates panel expansion / contraction
- ▶ Field-notch removes vertical panel stem on each side, leaving only the panel flat for the 1 1/2" to be hemmed
- ▶ 'L' is the Order Length : 80' max length, 6' min length

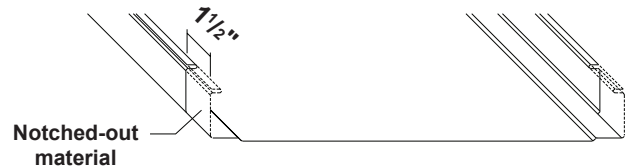

ENDLAP NOTCHED PANEL:

- ▶ Field-notch panels for endlapping
- ▶ Field-notch low end of up-slope panel
- ▶ Field-notch removes top hems, leaving the vertical stems and panel flat for the 3" to be endlapped
- ▶ 'L' is the Order Length : 80' max length, 6' min length

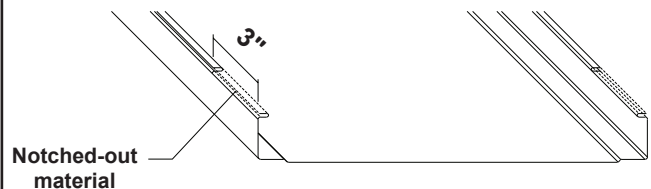

CAP END NOTCHING:

- ▶ All caps are provided as factory-notched
 - ▶ Notched end can be turned down at eave
 - ▶ Notched end can be used to endlap cap
 - ▶ Notched end can be placed under high side flashing
 - ▶ 'L' is the Order Length : 80' max length, 6' min length
- *Note eave turn down not recommended in high snow or high debris areas

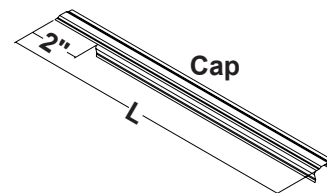

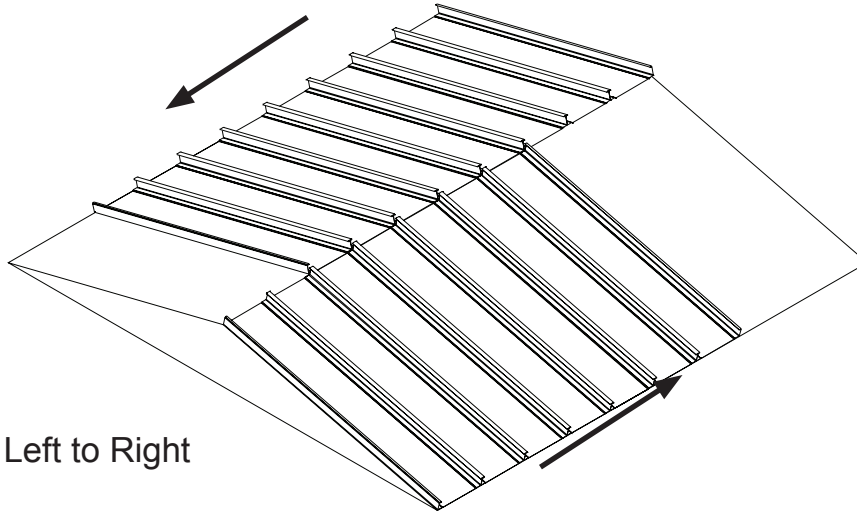

Install From Left to Right

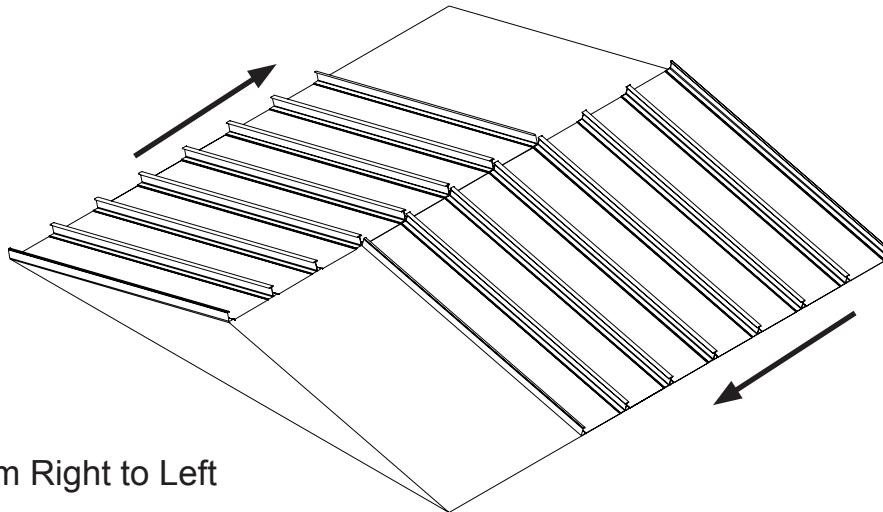

Install From Right to Left

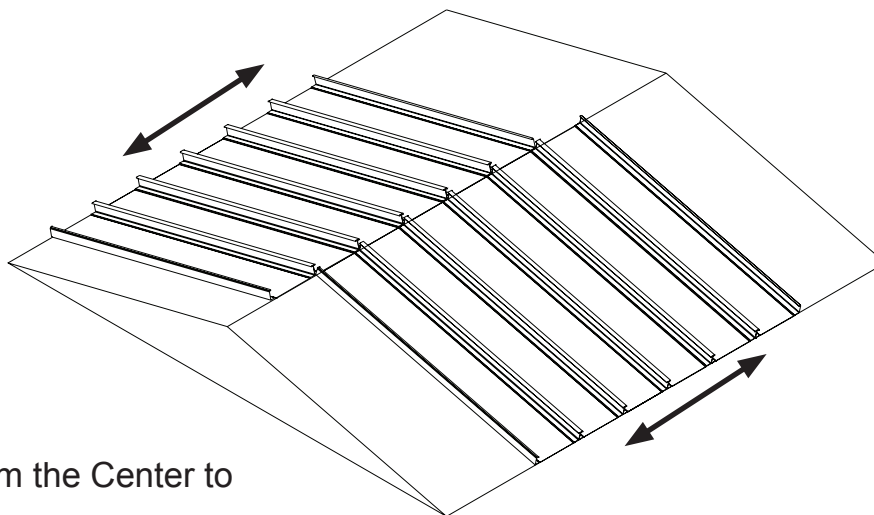

Install From the Center to the Ends

INSTALLING EAVE FLASHING

STEP
1

Steps:

1. For High clip, install the High Eave Plate first (not shown). Install Roof Cleat, fastening into roof framing with fasteners 1'-0" oc.
2. Hook Eave flashing onto the Roof Cleat and temporarily fasten into place.
3. Install continuous row of Double Bead Tape Sealant across the top of the Eave flashing.
4. Install Offset Cleat at Double Bead Tape Sealant and use #14-13 Deck Screws 1'-0" oc to fasten to the roof.

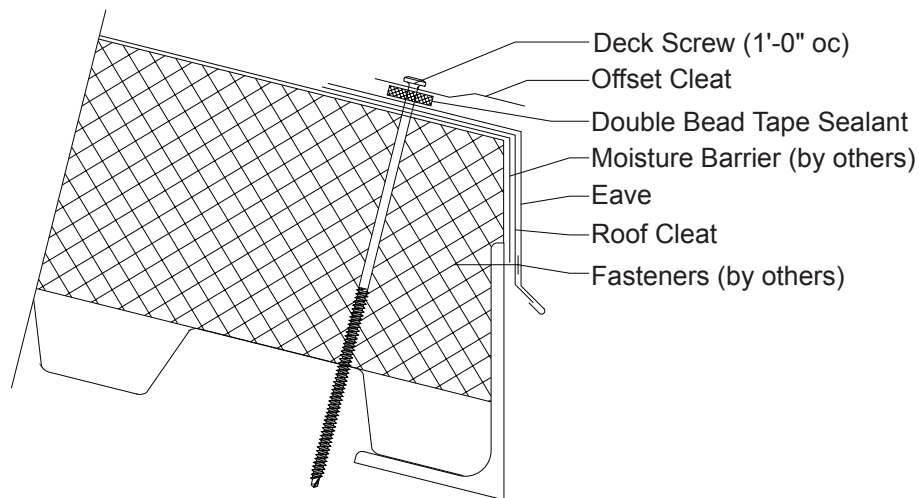

5. If two or more Eave flashings are required lap the flashing over the previously installed flashing by a minimum of 2" placing two beads of Tube Sealant between the flashings and secure with Pop Rivets 2.5" oc.

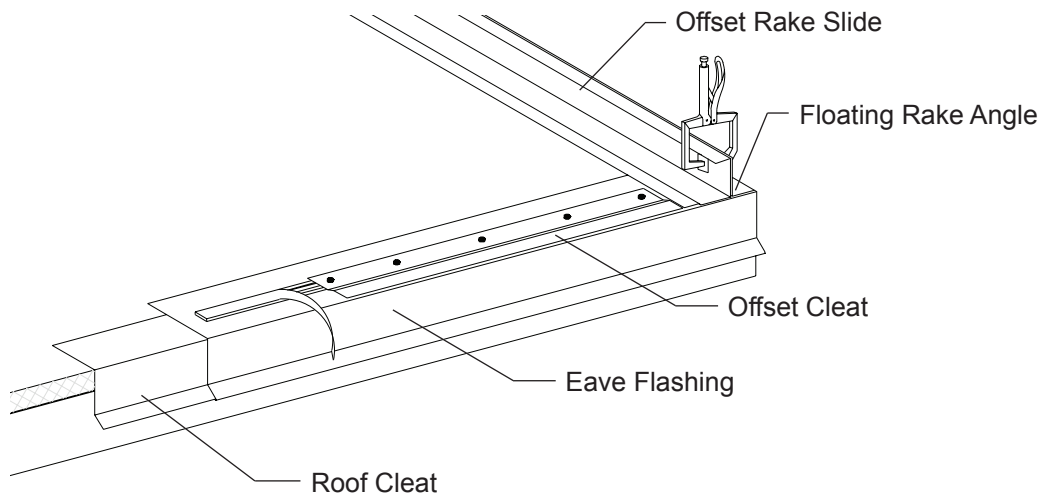

INSTALLING FLOATING RAKE ANGLE

STEP
2

Note: The Floating Rake Angle (page 14) must be attached to the framing member along the rake. Size of Floating Rake Angle can vary, (see System Components list on page 44). The following procedures are based on systems utilizing floating panel clips.

Steps:

1. At the eave of the building (looking eave to peak), align the Floating Rake Angle flush with the edge of the roof. **It is critical that the Floating Rake Angle be straight and square with the building as it controls the alignment of the roof panels.**
2. Fasten Floating Rake Angle with #14-13 Deck Screws (lengths vary per thickness of insulation) into the center of each slot, (1'-0" intervals). **Do not overtighten screws. Movement of the Floating Rake Angle is imperative for proper installation of the roof system.**
3. If two or more Floating Rake Angles are required, butt ends of Floating Rake Angles (**Do not overlap**) and continue fastening.

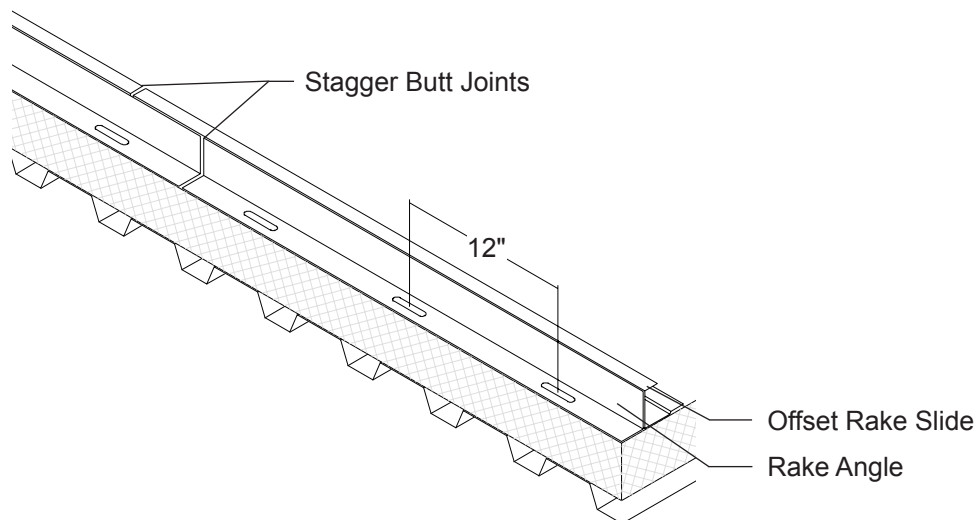

4. If necessary, field-cut Floating Rake Angle to terminate 6"-12" from peak of building.
5. Install Floating Rake Angle on the opposite end where the panels terminate using the same procedures as above.
6. Install Offset Rake Slide against the Floating Rake Angle, use a C-Clamp to temporary hold the Offset Rake Slide in place.
7. If two or more Offset Rake Slides are required, butt ends of Offset Rake Slides (**Do not overlap**) making sure to stagger the butt ends of the Floating Rake Angle.
8. Install a continuous row of Double Bead Tape Sealant to the side of the Offset Rake Slide

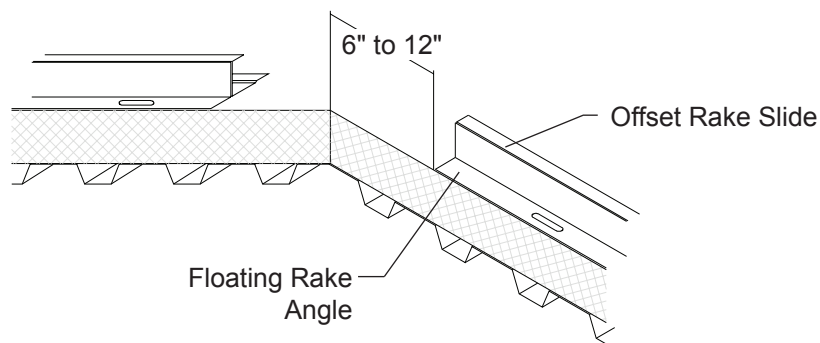

INSTALLING FIRST PANEL

STEP
3

Note: Eave, Gutter Drip, Gutter, Valley or any low side flashing must be installed prior to installation of roof panel. The following steps are for installing T-Armor from left to right. T-Armor may be installed from right to left or from the center outwards. (See page 46 for installation diagrams).

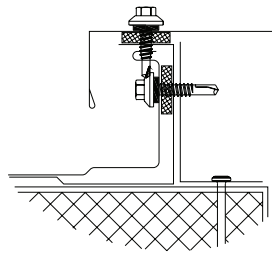

On Module

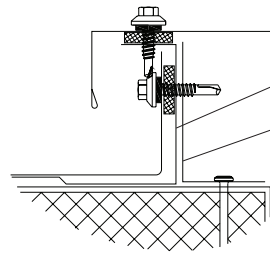

Off Module (field cut and bend)

Offset Rake Slide
Floating Rake Angle

Steps:

1. Place a row of Double Bead Tape Sealant across top of Eave flashing. Be sure to place sealant where fastener will be placed when using an Offset Cleat.
2. Position the first panel so the panel rib is on top of the Eave flashing and the panel is against the vertical leg of the Offset Rake Slide.
3. Slide the panel up the roof so it hooks onto the Offset Cleat.

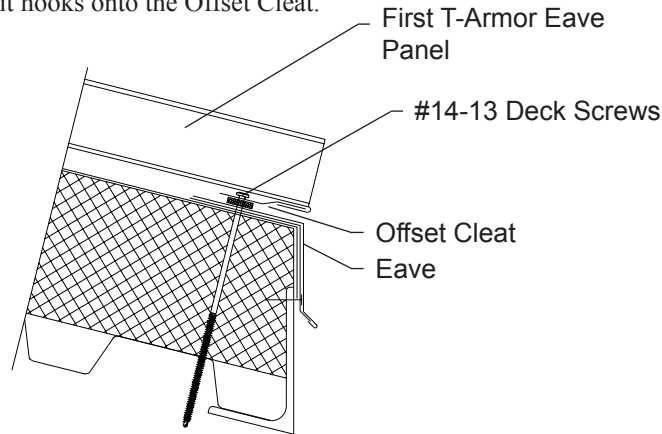

First T-Armor Eave Panel
#14-13 Deck Screws
Offset Cleat
Eave

4. Use a C-Clamp to hold the panel against the vertical leg of the Offset Rake Slide and Floating Rake Angle.
5. Recheck the panel overhang dimension at Eave, Ridge and Endlap if required, and adjust if necessary.

Note: It is critical that sealants be properly placed to prevent moisture leakage.

6. Apply two $\frac{3}{8}$ " beads of Tube Sealant along the side of the rib of the panel and across the horizontal portion of the top side of the rib directly over the Double Bead Tape Sealant on the Eave flashing. Be sure the Tube Sealant joins with the Double Bead Tape Sealant.
7. Peel back the paper backing covering the Double Bead Tape Sealant at the Eave flashing previously installed.
8. Use #12-14x $\frac{1}{4}$ " Self Driller XL screws at 1'-0" oc to fasten through the Panel, Offset Rake Slide and Floating Rake Angle.

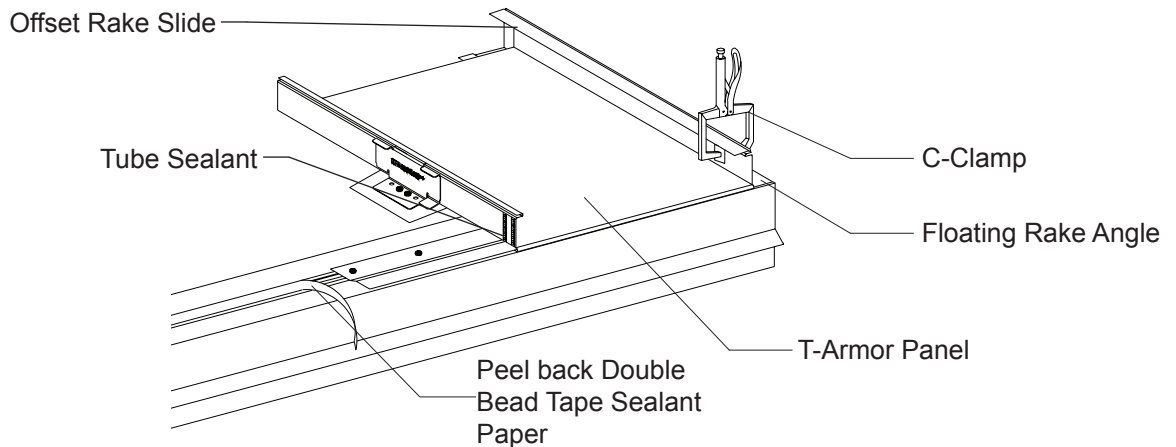

Offset Rake Slide
Tube Sealant
C-Clamp
Floating Rake Angle
T-Armor Panel
Peel back Double Bead Tape Sealant Paper

INSTALLING PANEL CLIPS

STEP
4

Note: The following procedures are based on installing panel clips over steel purlins. For fastening clips to a substructure other than steel, (see page 44). Design wind uplift requirements and insulation thickness must be considered for proper selection of clip type, size and spacing. (See Systems Components chart on page 44.)

Steps:

1. When installing over rigid insulation, bearing plates must be use at every clip location.
2. Place the panel clip in the groove of the panel rib.
3. Rotate the clip to a vertical position so that the lower tap of the clip rest under the bottom of the panel.
4. Fasten clip to metal deck with (2) #14-13 Deck Screws (length of screws will vary depending on the thickness of the roof assembly).
5. After installing clips along of the panel, measure across the pan of the panel to confirm panel modularity.

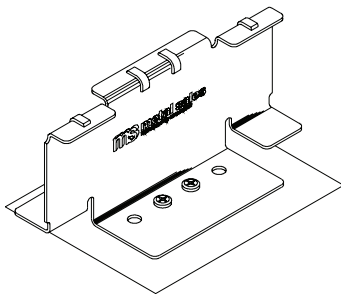

CORRECT

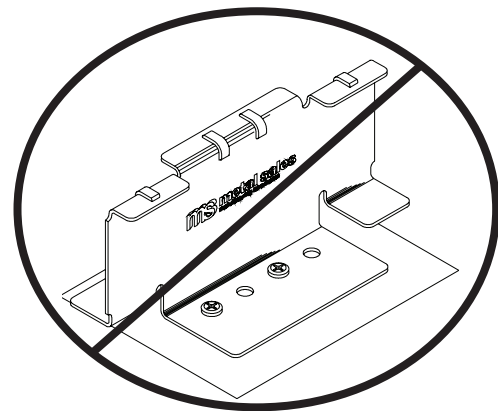
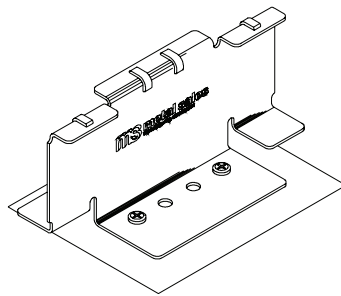

INCORRECT

Refer to the chart on page 44 for determination of the proper clip size. Correct clip size must be used for panel system to function properly.

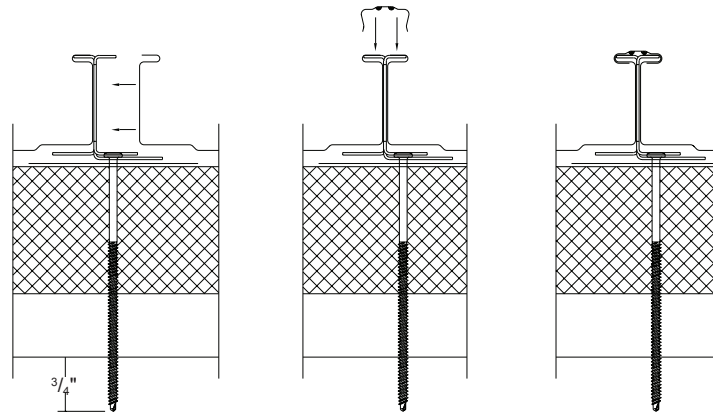

6. Slide next panel into place and place cap over both panels.
7. After second panel has been set in place, snap Cap over both panels and hand crimp in place (see page 56).

CAUTION

If a fastener strips out, you must remove the clip and reposition so the fastener can drill a new hole at least $\frac{3}{8}$ " from the stripped hole or install an oversized fastener in the stripped hole. Failure to do this will result in weakening the roof wind uplift resistance.

ENDLAPPING OF PANEL

STEP
5

Note: It is critical that panels located as detailed on erection drawings in order for panels to have adequate movement due to thermal expansion and contraction. Panels must be fixed at some point on the roof, typically the eave or ridge, but not in multiple locations. The following procedures also apply to panel runs with multiple laps. The distance between endlaps on a rib must be at least 24".

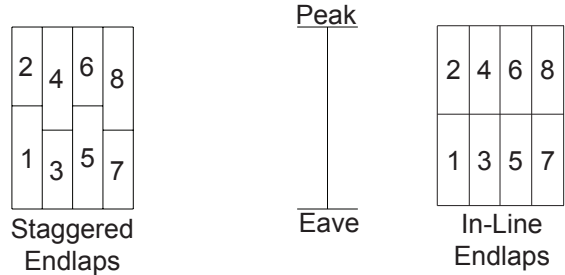

Steps:

1. The hems of the high end of the Eave Panel are field notched 3" to allow the Peak Panel to nest inside the Eave Panel.
2. Apply 2 rows of Endlap Pad on the notched end of the Eave Panel across panel flat.
3. Apply a row of Tube Sealant across each Endlap Pad and the side of the rib on both sides of the panels.
4. Set the Peak Panel in the Eave Panel.
5. Lap the Peak Panel onto the Eave Panel the 3" length of the notch.
6. Hold the flat of the Peak Panel up and nest the legs together.
7. Nest the flat of the Peak Panel into the Eave Panel.
8. Insert Stiffener Plate into the hems of the ribs and set in Tube Sealant. See Section A-A.
9. Apply a 2.5" Pig Tail of Endlap Pad around the hems of the panel where the panel notch occurs.
10. Install Cap on Eave Panel, ensuring the cap endlap occurs at least 1'-0" away from the panel endlap.
11. Apply Tube Sealant across each end of the cap notch.

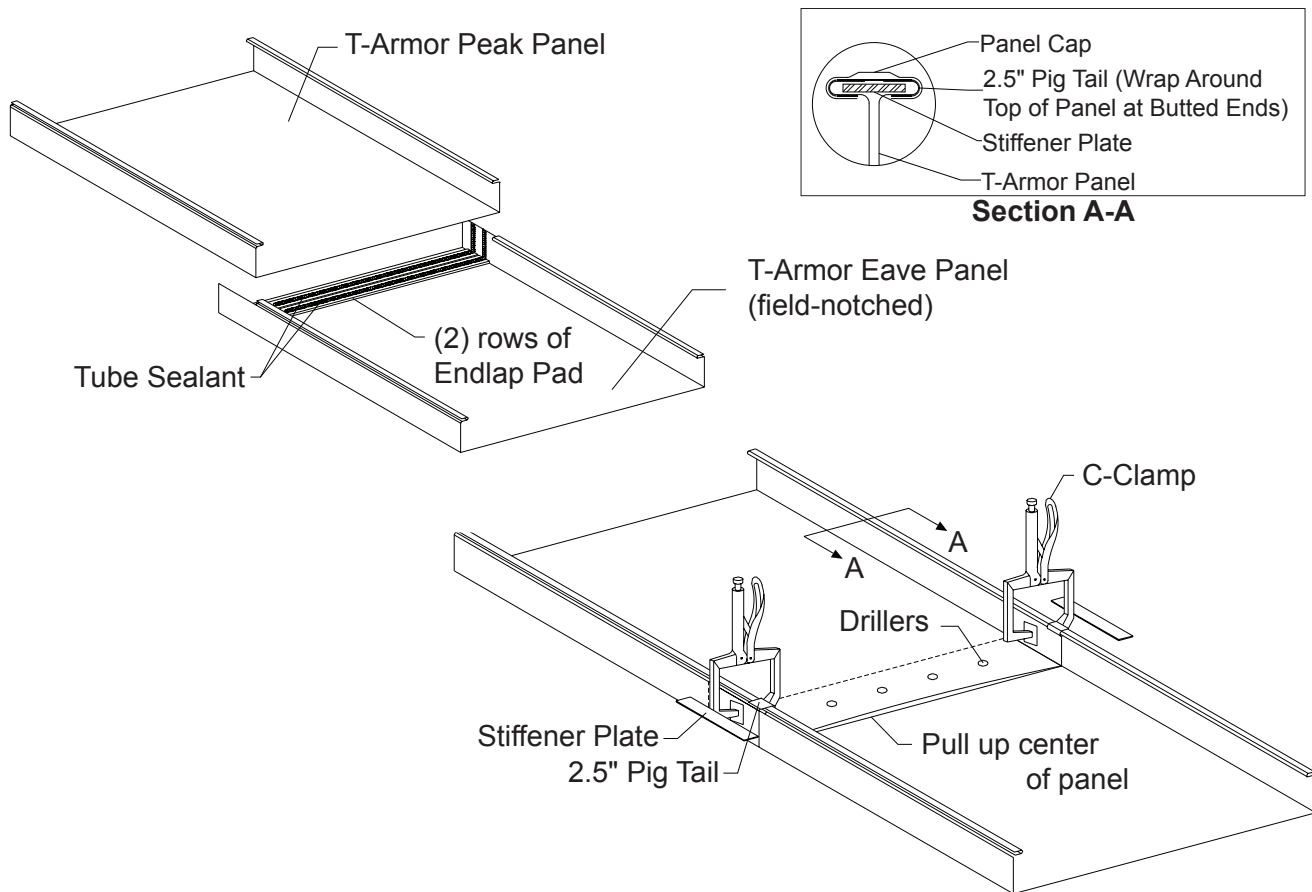

ENDLAP FASTENING PATTERN

12. Install Peak Cap.
13. Install #12-14x1 1/4" XL Self drilling screws (see below for number of fasteners require for each width of panel) and in accordance with fastening pattern sequence shown below. Do not exceed 2.5" between screws.
14. Repeat these steps for subsequent endlaps.

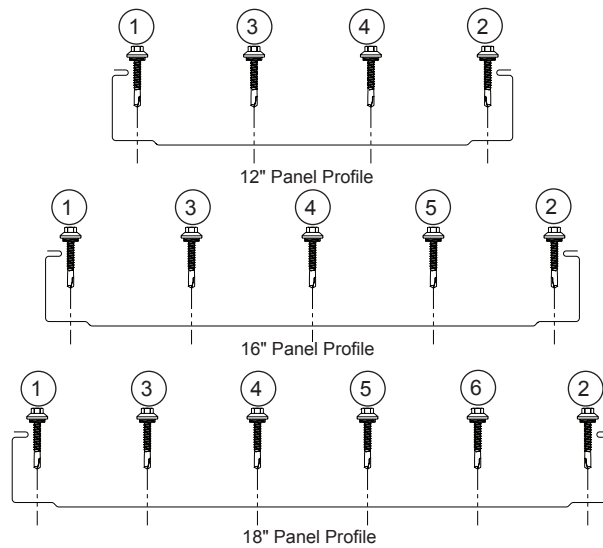

**Fastening Pattern for
End Laps and Panel End
Attachments**

SIDELAPPING OF PANEL

**STEP
6**
Steps:

1. Apply two $\frac{3}{8}$ " beads of Tube Sealant along the vertical side of the rib on the panel and across the horizontal portion of the top side of the rib directly over the Double Bead Tape Sealant on the eave flashing. Be sure the Tube Sealant joins with the Double Bead Tape Sealant.
2. Peel back the paper backing covering the Double Bead Tape Sealant at the eave flashing previously installed.
3. Roll the female leg of the second panel into place over the male leg of the first panel so their ends are flush. Do not let the flat of the second panel touch the Double Bead Tape Sealant at the eave until the ends are flush.

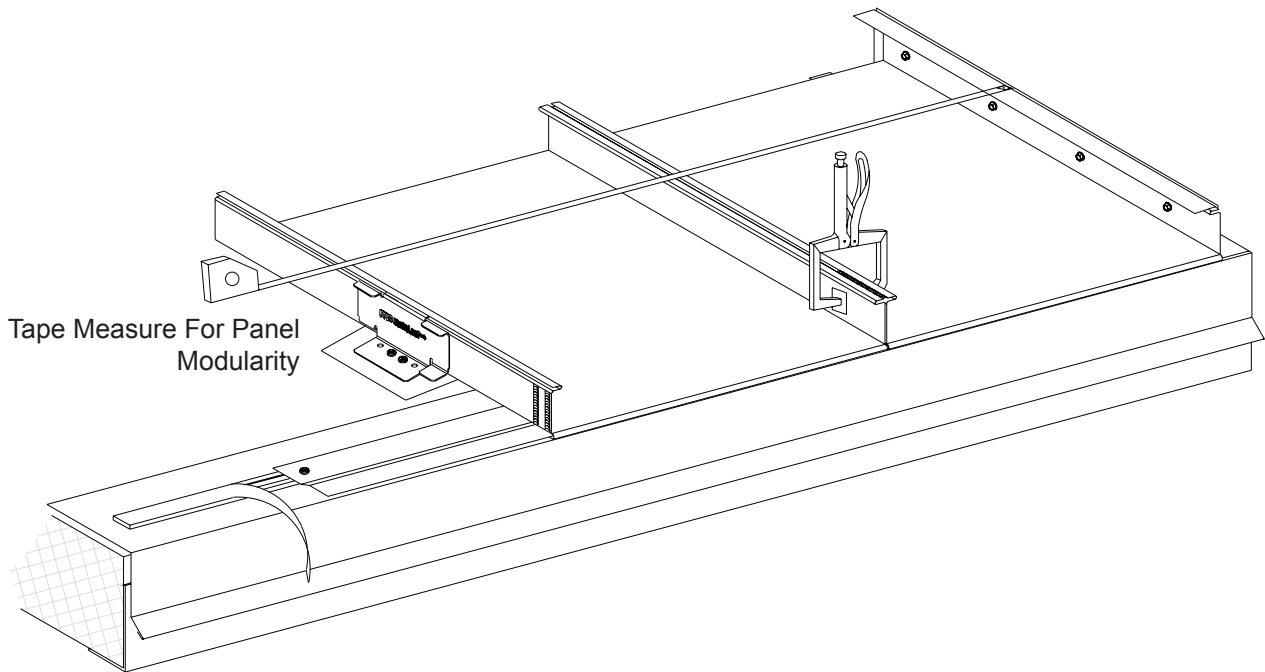

4. Use C-Clamps to hold the two vertical legs of the panel seams together.
5. Measure the distance from the first rib of the first panel installed. It is very important that the dimension from the start panel to the last male leg, at the eave and peak, be the same dimension within a $\frac{1}{4}$ " of each other.
6. Make certain that all clips are properly installed and that the panel sidelaps are properly positioned to be seamed. Use the Hand Crimper to crimp the panel seam at the eave and ridge ends only. This will adequately hold panels in place until fully seamed.

CAUTION

Hand crimping will not fasten the panels together tightly enough to withstand normal wind uplift forces. Be sure to seam all panels as soon as possible. (See seaming panels on pages 55 and 56 for proper seaming instructions.)

TERMINATION OF PANEL

STEP
7

Note: The following steps are for terminating a panel run when the pan width exceeds the remaining length of the building.

Steps:

1. When the roof panel installation has reached the opposite end of the roof, the last panel run may need to be field modified to attach to the Floating Rake Angle previously installed.
2. Measure the distance between the vertical leg of the last full panel run and the vertical leg of the Floating Rake Angle at the eave, endlap, and peak. See dimension "A".
3. Determine if a full panel will fit between the last full run and the Floating Rake Angle. In most cases it will not fit. If the full panel will fit, then continue with the installation of the roof. When the last panel is installed the vertical leg of the male side must fit flush with the Floating Rake Angle.

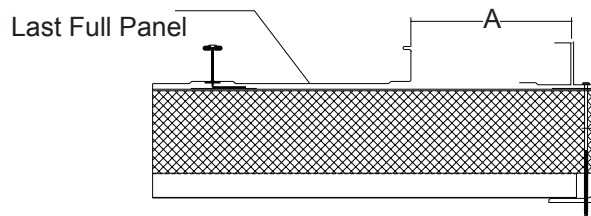

4. If a full panel is too wide to fit between the last full panel run and the Floating Rake Angle, a panel will have to be field cut and bent to simulate a male leg.
5. Use the dimension "A" and mark a line on the last panel to serve as the bend line. Mark a second line (the same dimension as the panel rib height) past the bend line to be the line you will cut off the excess panel.
6. Field-bend the roof panel up 90 degrees to from a vertical leg.
7. Place termination panel between last full panel and vertical leg of Floating Rake Angle making sure the panel fits properly.
8. Clamp termination panel to leg of Floating Rake Angle until Rake Detail is to be installed. (See page 63 for details.)

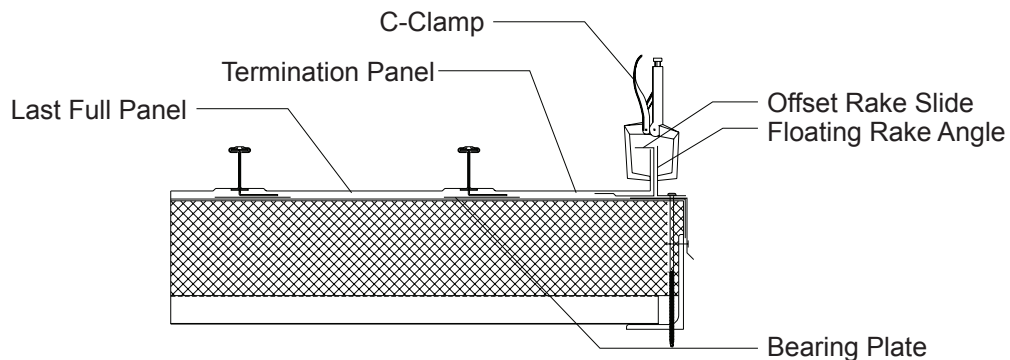
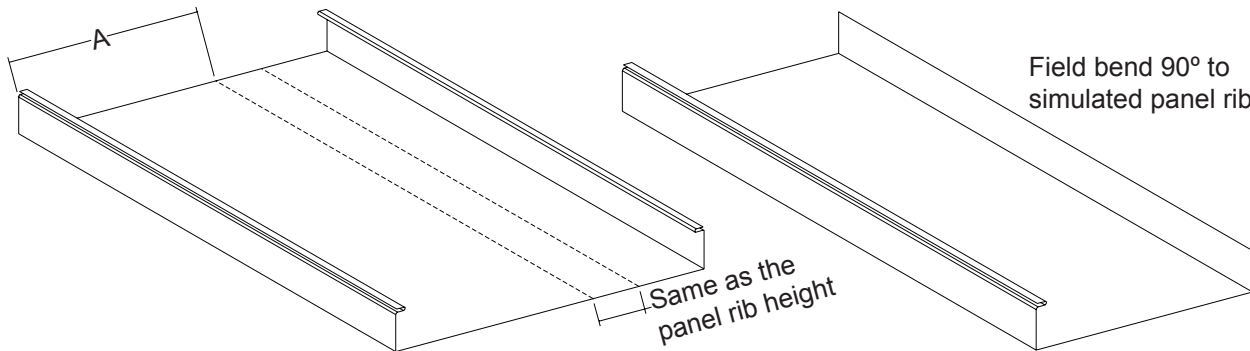

SEAMING PANELS

STEP
8

- Rental or purchase of the T-Armor mechanical seamer and hand crimpers for field-seaming are the responsibility of the installer. Mechanical seamers and hand crimpers can be aquired from:

Developmental Industries 915 Highway 45 Corinth, MS 38834 Phone 662.287.6626 www.msseamers.com	Quality Roof Seamers 8265 Highway 178 Olive Branch, MS 38654 Phone 662.895.1222 www.qualityroofseamers.com
---	---
- Read the field manual that is enclosed in the case with the seamer. The operator should adhere to all instructions for proper use of the seamer. Failure to follow the required instructions may result in damage to the panel and/or seamer. Metal Sales will not be responsible for damage incurred by improper use of the seamer.
- All panel sidelaps should be seamed with mechanical seamer as soon as possible, after the panels have been installed. Hand crimping the panel sidelaps 8” at the eave, endlap and ridge locations of the panel will help keep the panels in place during normal erection, but will not prevent the panels from being blown off the roof by moderate strong winds.
- At endlap conditions, panels must be handcrimped only. Mechanical seaming of panels will cause rib distortion due to multiple thicknesses along the endlap.
- Run sufficient power to the roof to operate the seamer. If the job site is a long distance from the roof or if the roof is large, consider using a portable generator placed on the roof near the seaming operation.
- Do not overload or damage the roof with the generator unit. Be sure to follow OSHA and local electrical codes when installing generator.
- Prior to seaming panels check all seams making sure they are properly engaged. All dirt, debris and excess sealant should be removed from flat part of panel and seams.
- A Hand Swedger that is needed for preparing the Peak Panel in an endlap may be rented from Developmental Industries.

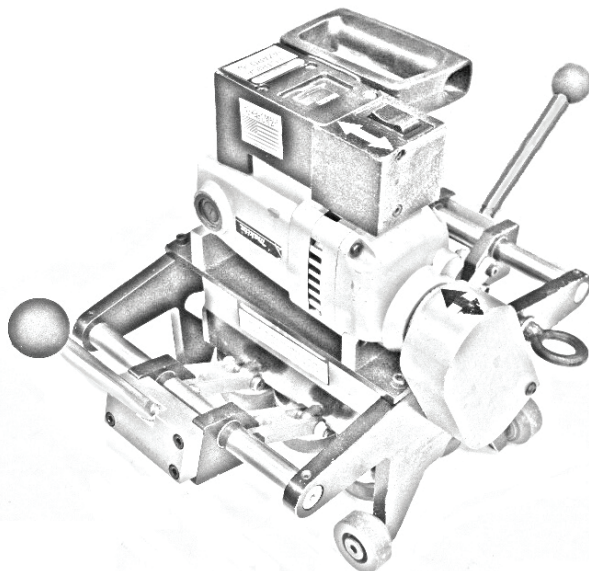

MECHANICAL SEAMER

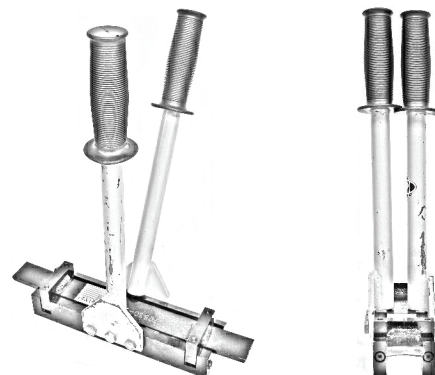

HAND CRIMPER

SEAMING PANELS (CONT.)

Steps:

1. To start seaming, hand crimp the first 8" of seam at eave, the cap overlap, and ridge locations. Other areas such as at clips may be hand crimped, but this additional hand crimping is not necessary.

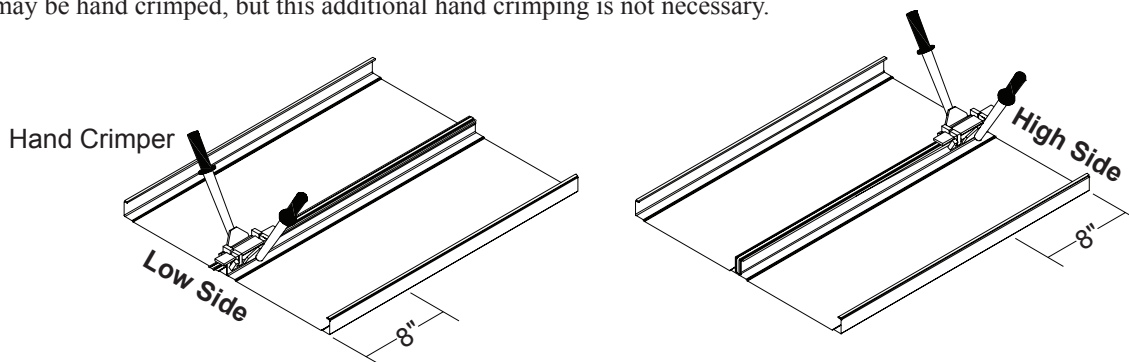

2. Position mechanical seamer over hand crimped roof seam at ridge location so that the levers are on the same side of the seam that is to be crimped by the mechanical seamer.
3. Engage roller levers on both sides of seamer.
4. Prior to running seamer, check to make sure that T-Armor panels are fully engaged along the entire run of the panel. Small C-Clamps may be required on the horizontal portion of the seam to hold panel seam engaged while seaming.

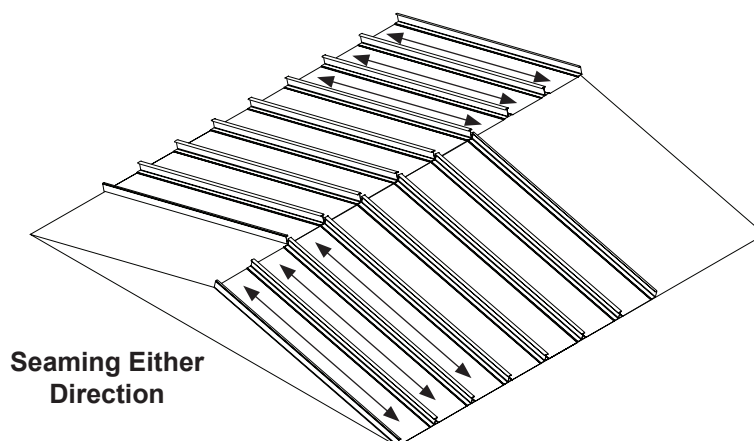

5. Turn on the power to seamer and walk with the seamer as it seams the panel. Stop the seamer in the first few feet to ensure proper seam is being achieved. Turn the mechanical seamer off before the hand crimped end portion of the panel. Remaining seam between hand crimped portion and mechanically seamed portion may have to be hand crimped for continuous tight seam.
6. At the end of the first run, remove mechanical seamer and return to step #1 for remaining panels.
7. At completion of seaming, repack tool and return to the seamer company. See page 55 for information.

NOTE:

Contact your local sales branch (see page 2) for directions concerning proper removal of damaged panels and installation of replacement panels. See page 79 for instruction on panel removal

CAUTION

Do not run the seamer off the end of the panel. If the seamer is run off the end of the roof it could cause injury to personnel and damage the roof or the seamer. (See seamer instructions enclosed in the case for additional information about the proper handling of the seamer.)

1/2:12 Slope
Minimum

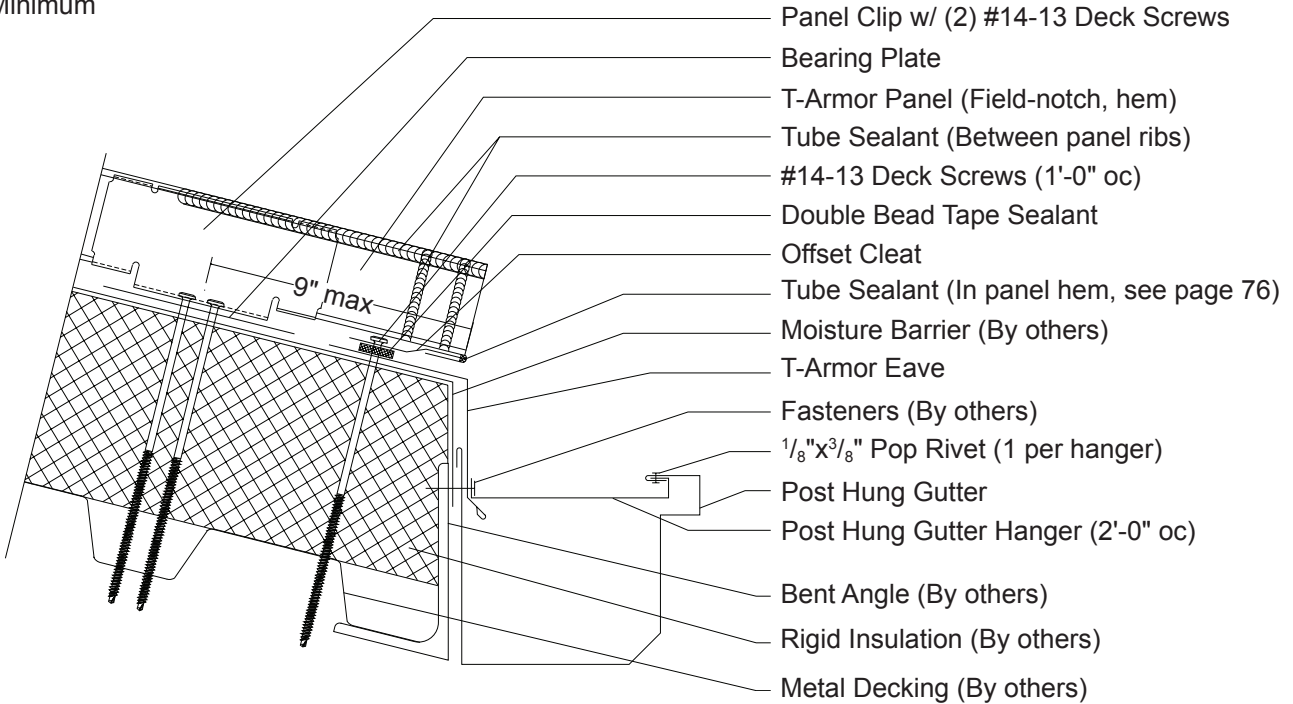

Panel cap not shown for clarity.
For High Clips, install High Eave Plate before T-Armor Eave.

CAUTION

In locations where heavy rainfall or severe ice and snow may occur, Metal Sales' standard gutters may not be suitable for use.

INSTALLATION NOTES

All T-Armor Eave must be installed prior to panel installation.

1. Install new T-Armor Eave over top of rigid board insulation to hold T-Armor Eave into place, fasten to substrate at 4'-0" oc.
2. Apply a continuous row of Double Bead Tape Sealant across the T-Armor Eave.
3. Install Offset Cleat at Double Bead Tape Sealant locations and secure with #14-13 Deck Screws at 1'-0" oc.
4. Install the panels by hooking the hemmed edge of the panel (see 76 for Hemming Instructions) around the end of the Offset Cleat.
5. Apply Tube Sealant up the side and across the top of the panel ribs before installing the next panel.
6. Install the Post Hung Gutter by sliding it behind the T-Armor Eave. Install the Post Hung Gutter Hanger at 2'-0" oc fastening through the T-Armor Eave into the roof framing.
7. If two or more flashings are required, lap the flashing over the previously installed flashing by a minimum of 2" placing two rows of Tube Sealant between the flashings and secure with Pop Rivets, 2.5" oc.

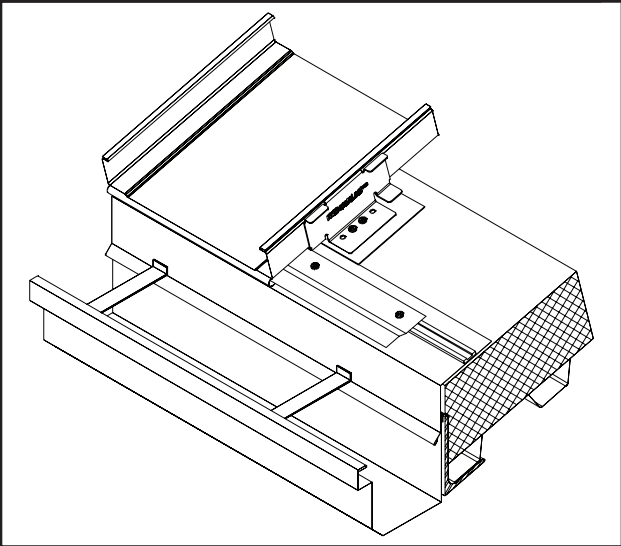

1/2:12 Slope
Minimum

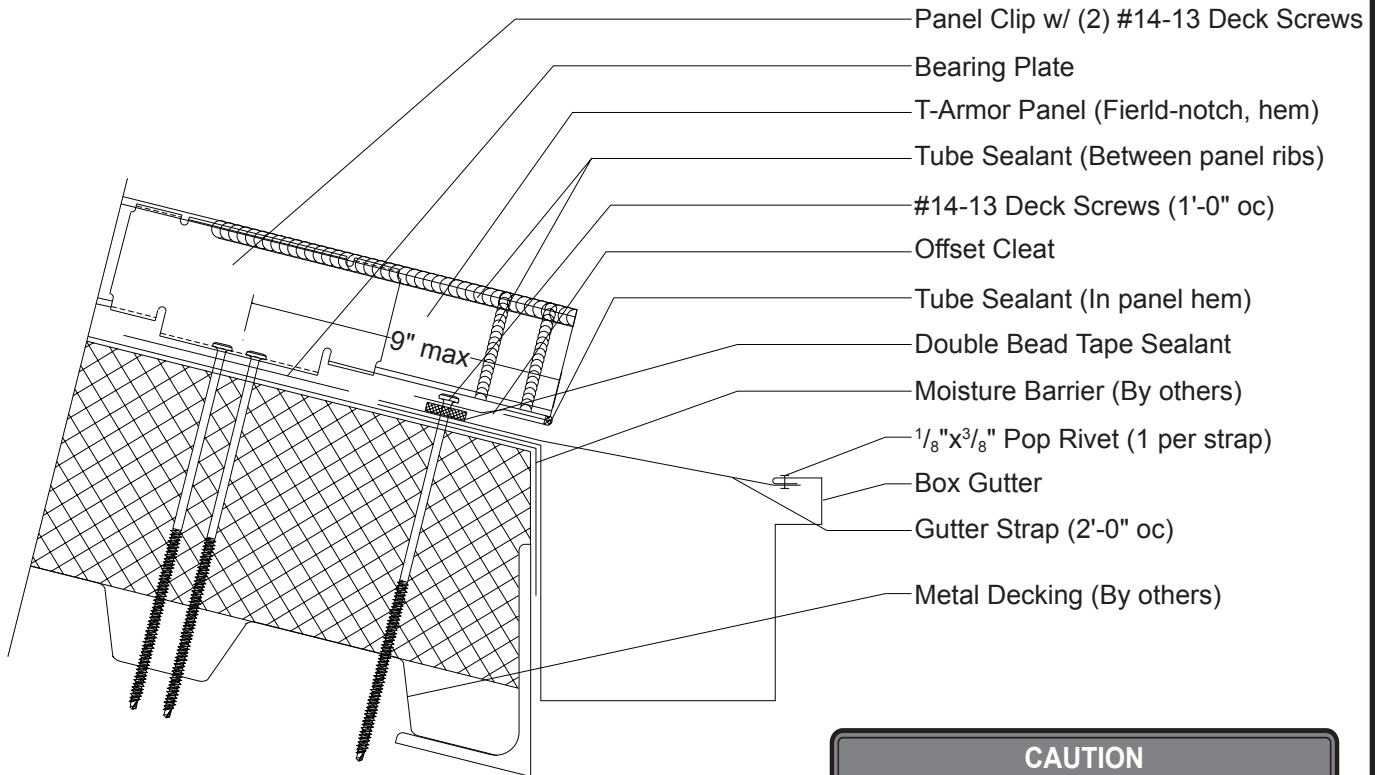

Panel cap not shown for clarity.
For High Clips, install High Eave
Plate before T-Armor Eave.

CAUTION
In locations where heavy rainfall or severe ice and snow may occur, Metal Sales' standard gutters may not be suitable for use.

INSTALLATION NOTES

All gutter flashings must be installed prior to panel installation.

1. Install new Box Gutter over top of rigid board insulation. To hold Box Gutter in place fasten to substrate with fasteners 4'-0" oc.
2. Apply a continuous row of Double Bead Tape Sealant across the Box Gutter.
3. If two or more flashings are required, lap the flashing over the previously installed flashing by a minimum of 2" placing two rows of Tube Sealant between the flashings and secure with Pop Rivets, 2.5" oc.
4. Field-bend and place Gutter Straps at 2'-0" oc (maximum).
5. Install Offset Cleat at Double Bead Tape Sealant locations and secure with #14-13 Deck Screws at 1'-0" oc.
6. Install the panels by hooking the hemmed edge of the panel (see page 76 for Hemming Instructions) around the end of the Offset Cleat.
7. Apply Tube Sealant up the side and across the top of the panel ribs before installing the next panel.

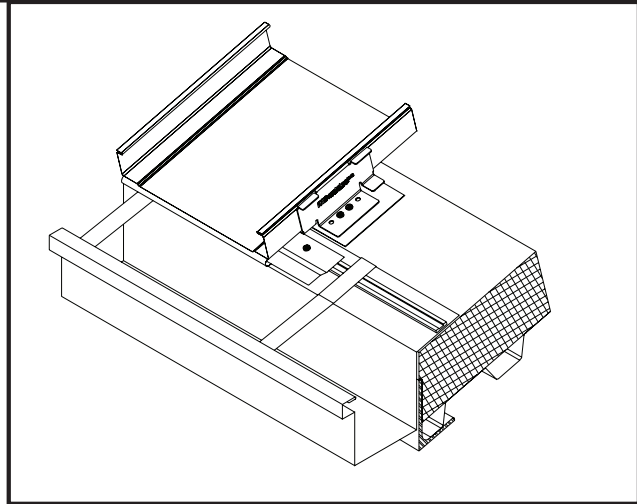

1/2:12 Slope
Minimum

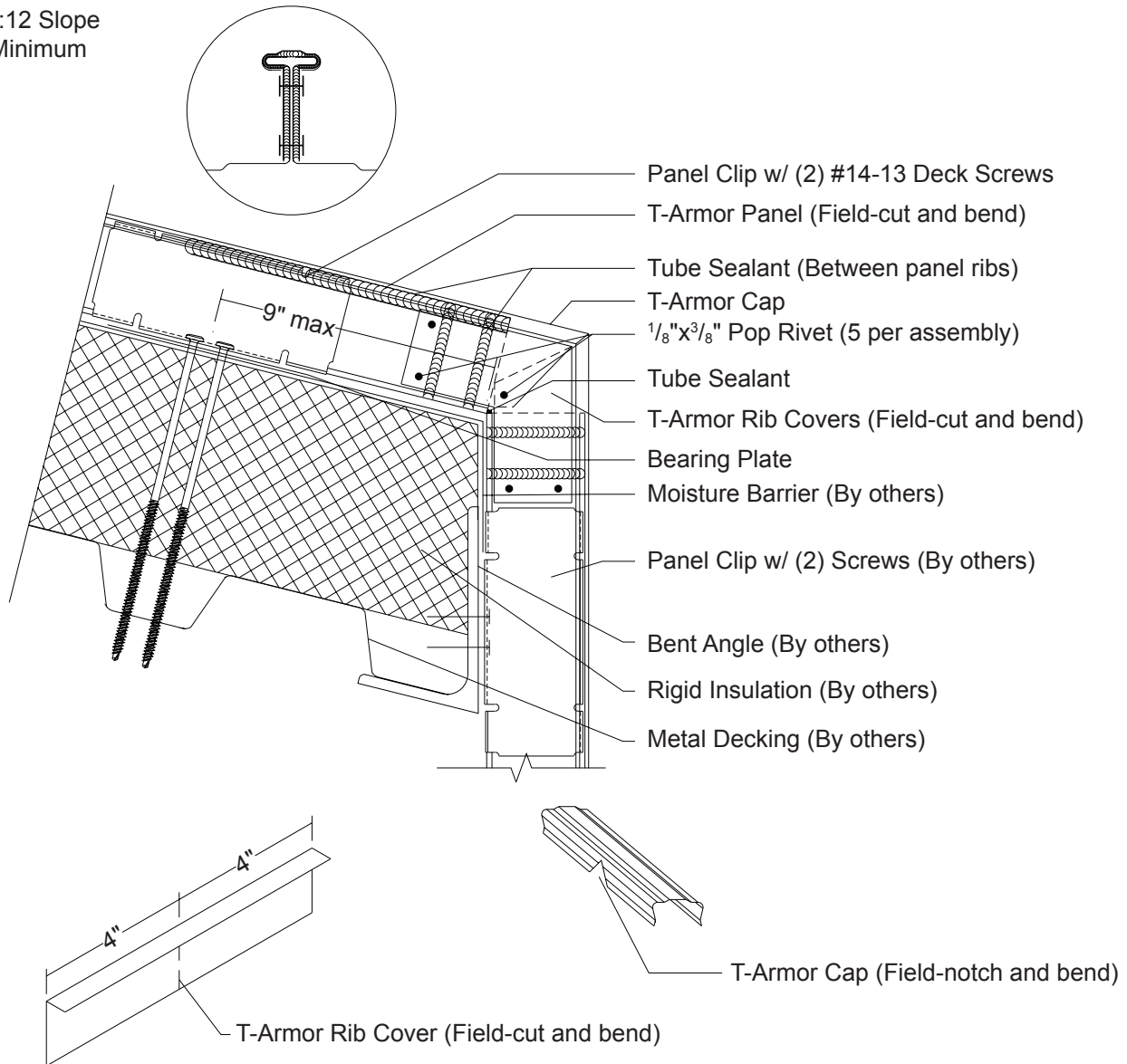

INSTALLATION NOTES

NOTE:

Longer Pop Rivets may be required depending on the thickness of the materials being used.

1. Field-cut the panel ribs and bend pan of panel.
2. Set panel on the roof substrate and apply panel clip 6" maximum from the end of the roof.
3. Apply four rows of Tube Sealant (2 on either side of the cut) up the side of the panel rib.
4. Field-cut and bend T-Armor Rib Covers (2 required for each rib), and fasten with 5 Pop Rivets per connection.
5. Field-notch panel Cap and bend, set on top of panel rib and hand crimp into place.
6. Fill any gaps or opening with Tube Sealant.

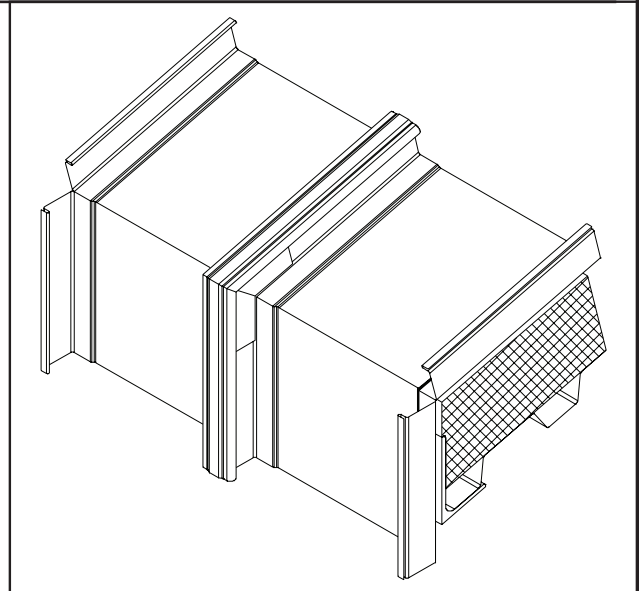

1/2:12 Slope
Minimum

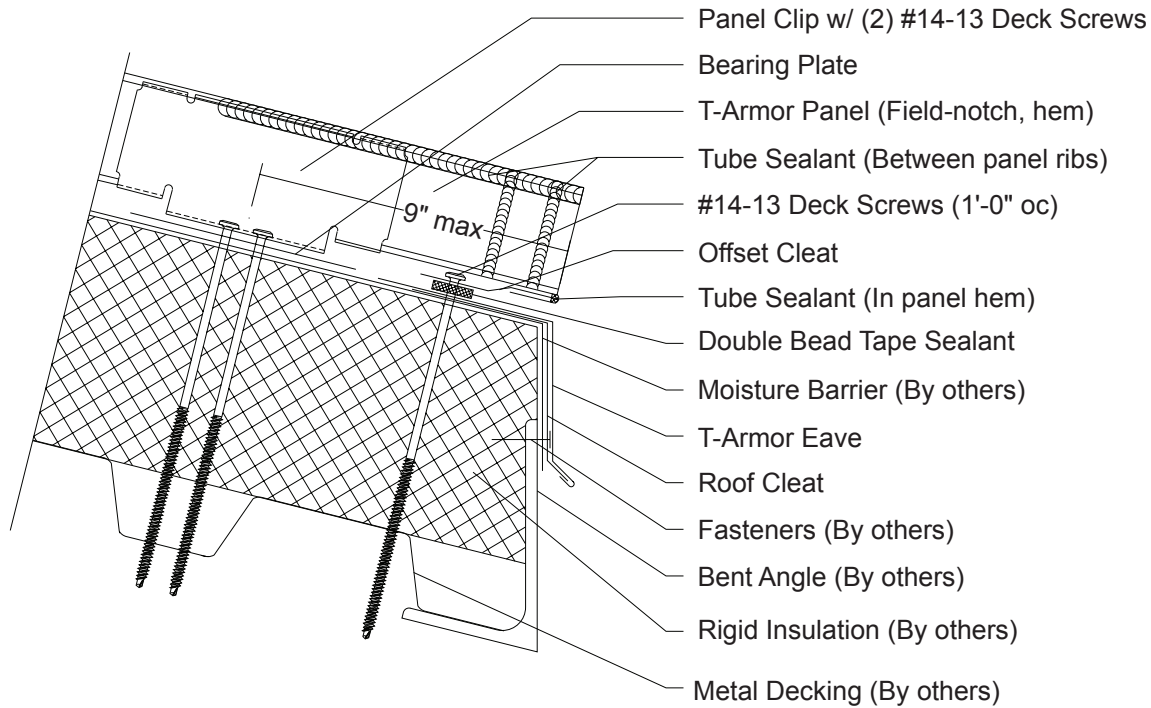

Panel cap not shown for clarity.
For High Clips, install High Eave
Plate before T-Armor Eave.

INSTALLATION NOTES

All T-Armor Eave must be installed prior to panel installation.

1. Install new Roof Cleat by fastening to substrate at 4'-0" oc.
2. Install new T-Armor Eave by engaging Roof Cleat and rotating on to rigid board insulation. To hold T-Armor Eave in place fasten to substrate at 4'-0" oc.
3. If two or more flashings are required, lap the flashing over the previously installed flashing by a minimum of 2" placing two rows of Tube Sealant between the flashings and secure with Pop Rivets, 2.5" oc.
4. Apply a continuous row of Double Bead Tape Sealant across the T-Armor Eave.
5. Install Offset Cleat on Double Bead Tape Sealant locations and secure with #14-13 Deck Screws at 1'-0" oc.
6. Install the panels by hooking the hemmed edge of the panel (see page 76 for Hemming Instructions) around the end of the Offset Cleat.
7. Apply Tube Sealant up the side and across the top of the panel ribs before installing the next panel.

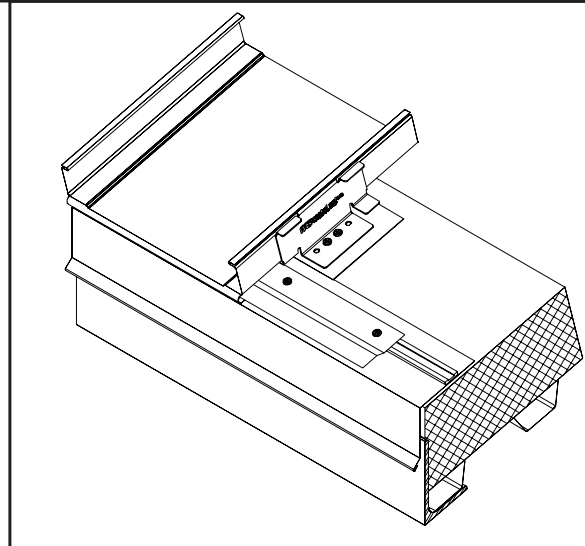

3:12 Slope
Minimum

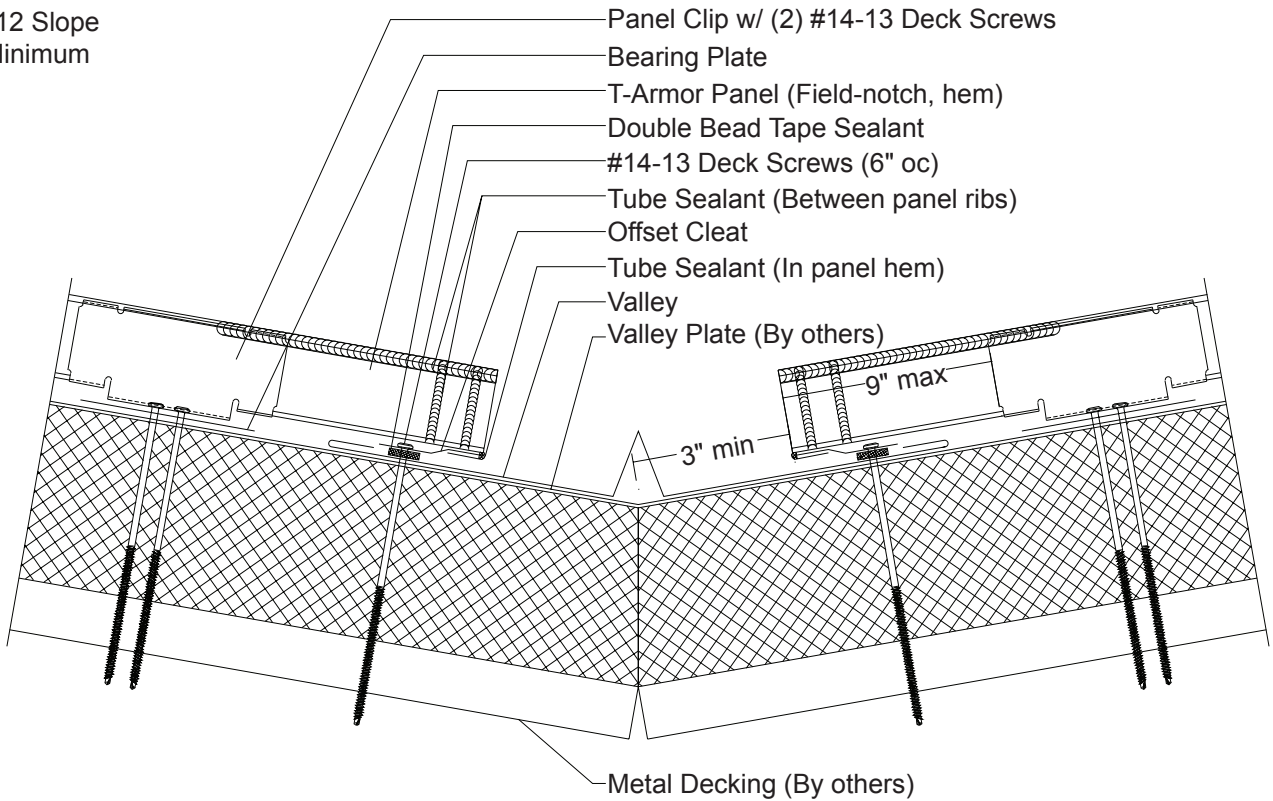

Panel cap not shown for clarity.
For High Clips, use Drop Valley on
Hogh Eave Plates.

INSTALLATION NOTES

All valley flashings must be installed prior to panel installation.

1. Install new Valley over top of rigid board insulation. To hold Valley in place fasten to substrate with fasteners at 4'-0" oc.
2. If two or more flashings are required, lap the upslope flashing over the previously installed flashing by a minimum of 6" placing two rows of Tube Sealant between the flashings. Locate beads of Tube Sealant so that it does not press out of the lap. Do not install any fasteners through the Valley lap.
3. Apply a continuous row of Double Bead Tape Sealant across each side of the Valley.
4. Install Offset Cleats on Double Bead Tape Sealant and secure with #14-13 Deck Screws at 6" oc.
5. Install the panels by hooking the hemmed edge of the panel (see page 76 for Hemming Instructions) around the end of the Offset Cleats.
6. Apply Tube Sealant up the side and across the top of the panel ribs before installing the next panel.

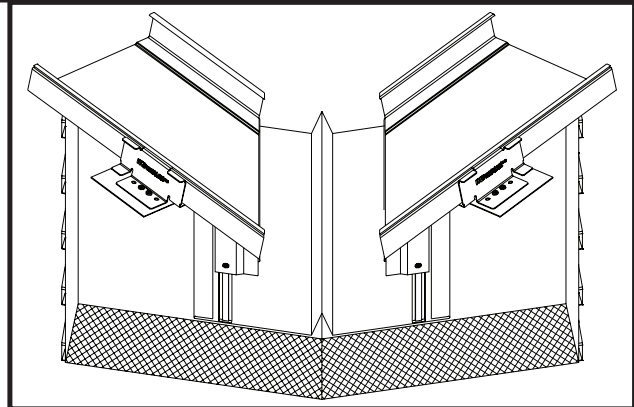

1/2:12 Slope
Minimum

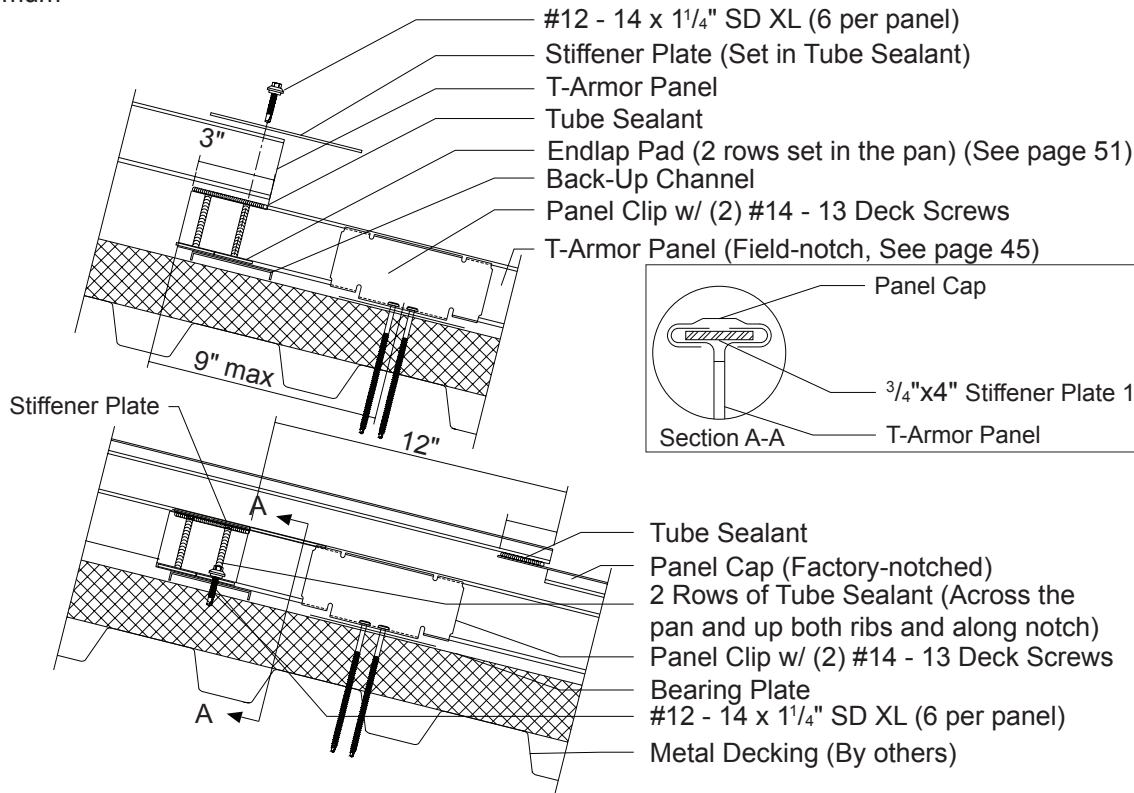

This detail should only be used with Low or High Clips.

INSTALLATION NOTES

Note: Panel Endlaps may be staggered and must be hand crimped. Do not run the mechanical seamer over the Endlap.

1. Once the field-notched (see page 45) Eave Panel has been installed, apply two rows of Endlap Pad (see page 51) across flat pan of the panel.
2. Apply a bead of Tube Sealant across each Endlap Pad, up both vertical ribs and along the notch.
3. Set the Peak Panel into place and nest with Eave Panel so that the 3" notch is completely covered. (See page 51 for complete details on installing endlapped panels.)
4. Apply a bead of Tube Sealant at the butted ends of the panel hems. Insert Stiffener Plate into butted panel hems, set in the Tube Sealant.
5. Use a C-Clamps to hold panels and Back-Up Plate in place. Install #12 - 14 x 1 1/4" DS XL screws (see page 52 for number of fasteners and order).
6. Install Eave Cap, apply a bead of Tube Sealant across the width of the end of the notch and install the Peak Cap. The Cap endlap must be located a minimum of 12" away from the panel endlap.

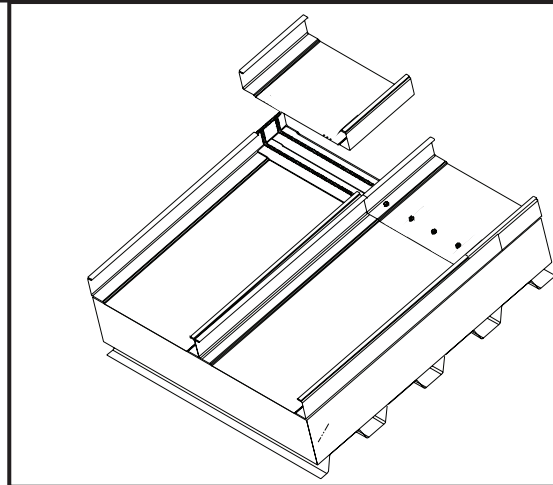

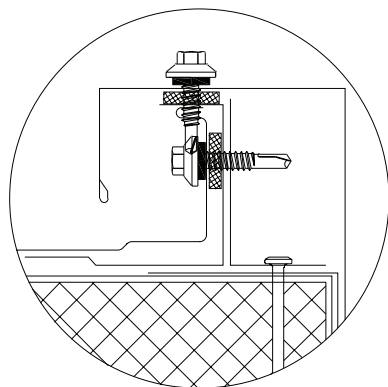

ON MODULE

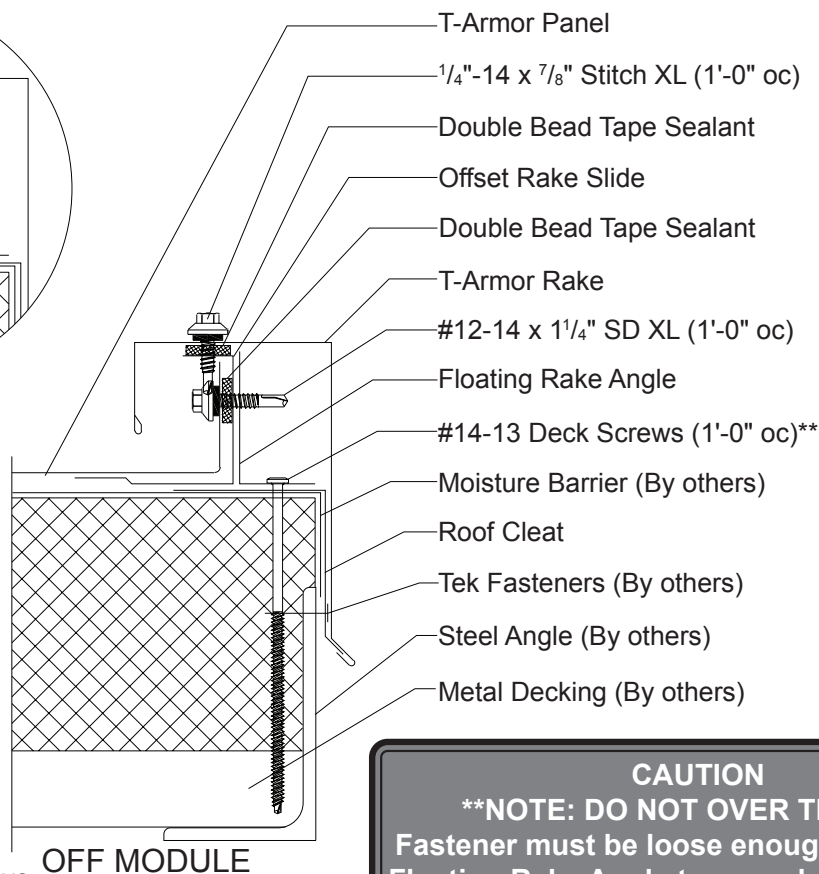

OFF MODULE

Field-close Rake at the Eave.
(low end of the flashing run)

CAUTION
****NOTE: DO NOT OVER TIGHTEN.**
 Fastener must be loose enough to allow for
 Floating Rake Angle to move back and forth.

INSTALLATION NOTES

Floating Rake Angle and T-Armor panels must be installed prior to T-Armor Rake installation (See pages 47-56).

1. Install Roof Cleat on top of rigid insulation. To hold flashing in place fasten to substrate with fasteners at 4'-0" oc.
2. With T-Armor panel properly nested beside Offset Rake Slide, apply a row of Double Bead Tape Sealant across upper side of Offset Rake Slide.
3. Fasten through Offset Rake Slide, Tape Sealant, panel and into Floating Rake Angle with #12-14 x 1 1/4" Self Driller XL screws, 1'-0" oc.
4. Apply row of Double Bead Tape Sealant on top of Offset Rake Slide.
5. Install T-Armor Rake so that the top of the flashing is flush with top of Offset Rake Slide and panel rib. Fasten through T-Armor Rake, Tape Sealant and into Offset Rake Slide with 1/4"-14 x 7/8" Stitch XL screws, 1'-0" oc.
6. If two or more flashings are required, lap the flashing over the previously installed flashing by a minimum of 2" placing a bead of Tube Sealant between the flashings and secure with Pop Rivets, 2.5" oc.

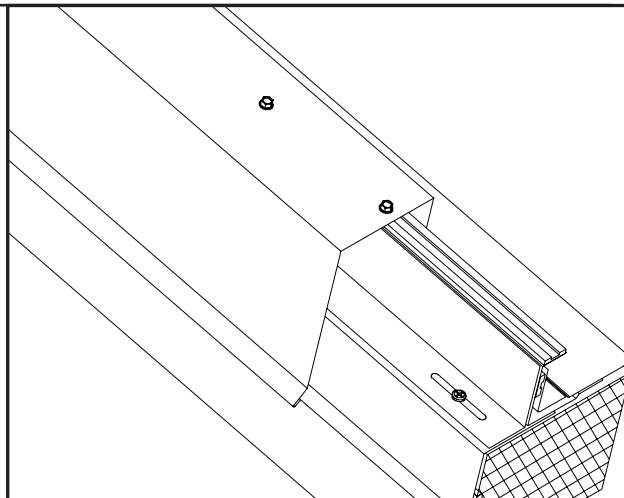

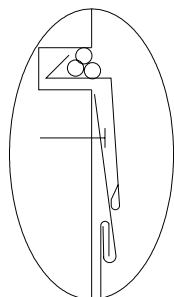

With Reglet

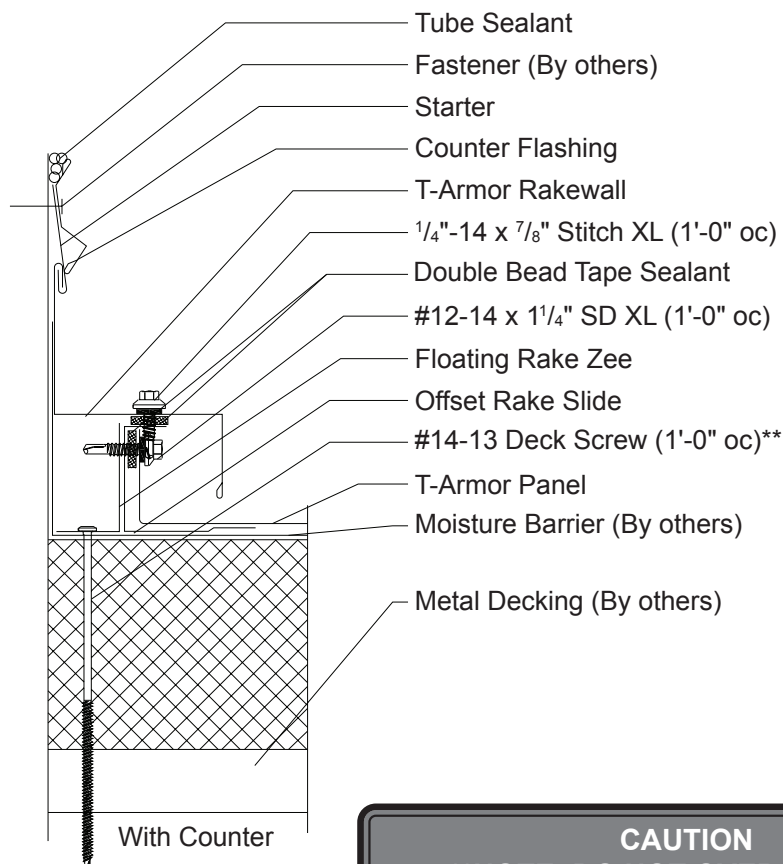

With Counter

CAUTION
****NOTE: DO NOT OVER TIGHTEN.**
 Fastener must be loose enough to allow for Floating Rake Angle to move back and forth.

INSTALLATION NOTES

Floating Rake Angle and T-Armor panels must be installed prior to T-Armor Rakewall installation (See pages 47-56).

1. With T-Armor panel properly nested beside Offset Rake Slide, apply a row of Double Bead Tape Sealant across upper side of Offset Rake Slide.
2. Fasten through Offset Rake Slide, Tape Sealant, panel and into Floating Rake Angle with #12-14 x 1 1/4" Self Driller XL screws, 1'-0" oc.
3. Apply row of Double Bead Tape Sealant on top of Offset Rake Slide.
4. Install T-Armor Rakewall so that top of the flashing is flush with top of Offset Rake Slide and panel rib. Fasten through T-Armor Rakewall, Tape Sealant and into Offset Rake Slide with 1/4"-14 x 7/8" Stitch XL screws, 1'-0" oc.
5. Install Counter Flashing, Reglet or wall panel and fasten to parapet wall with appropriate fastener, 1'-0" oc. If Counter Flashing or Reglet is used, seal to wall with Tube Sealant. **Do NOT fasten T-Armor Rakewall to parapet wall.**
6. If two or more flashings are required, lap the upslope flashing over the previously installed flashing by a minimum of 2" placing a bead of Tube Sealant between the flashings and secure with Pop Rivets, 2.5" oc.

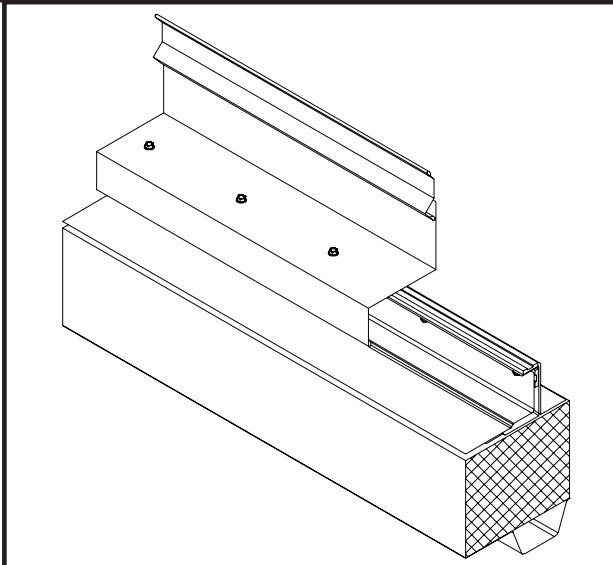

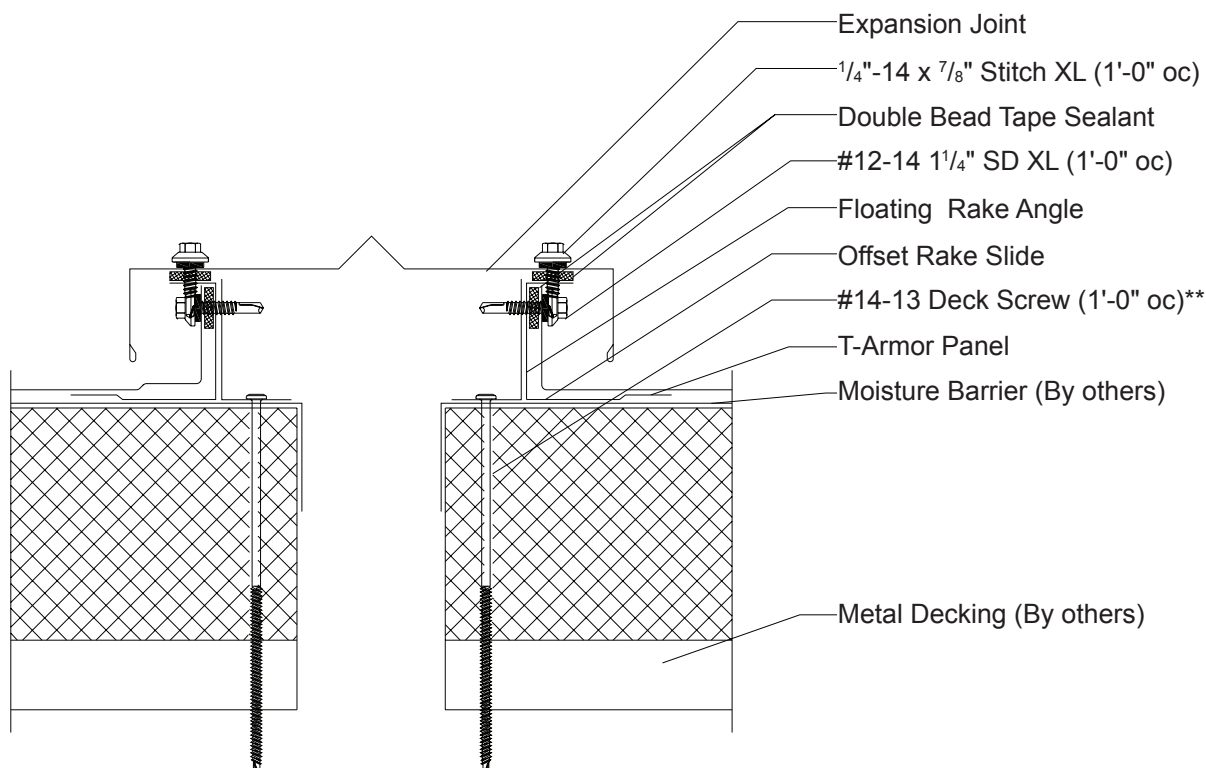

CAUTION
****NOTE: DO NOT OVER TIGHTEN.**
 Fastener must be loose enough to allow for Floating Rake Angle to move back and forth.

INSTALLATION NOTES

Floating Rake Angle and T-Armor panels must be installed prior to Expansion Joint installation (See pages 47-56).

1. With T-Armor panel properly nested beside Offset Rake Slide, apply a row of Double Bead Tape Sealant across upper side of Offset Rake Slide.
2. Fasten through Offset Rake Slide, Tape Sealant, panel and into Floating Rake Angle with #12-14 x 1 1/4" Self Driller XL screws, 1'-0" oc.
3. Apply row of Double Bead Tape Sealant on top of Offset Rake Slide.
4. Install Expansion Joint so that top of the flashing is flush with top of Offset Rake Slide and panel rib. Fasten through Expansion Joint, Tape Sealant and into Offset Rake Slide with 1/4"-14 x 7/8" Stitch XL screws, 1'-0" oc.
5. If two or more flashings are required, lap the upslope flashing over the previously installed flashing by a minimum of 2" placing a bead of Tube Sealant between the flashings and secure with Pop Rivets, 2.5" oc.

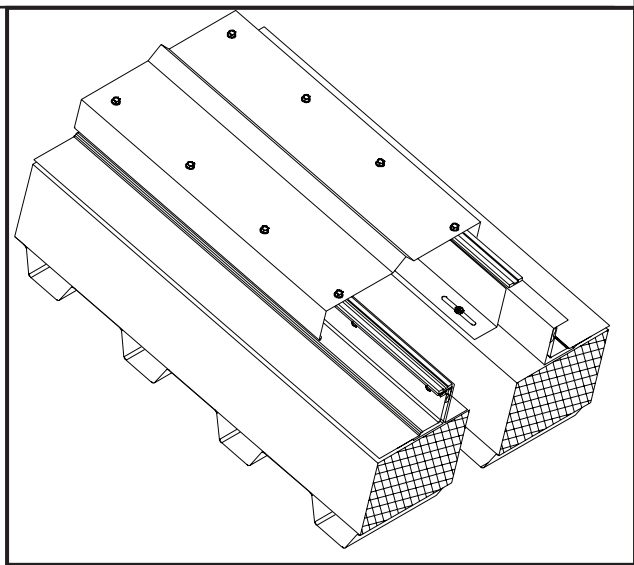

1/2:12 Slope
Minimum

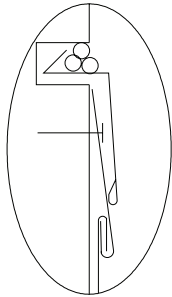

With Reglet

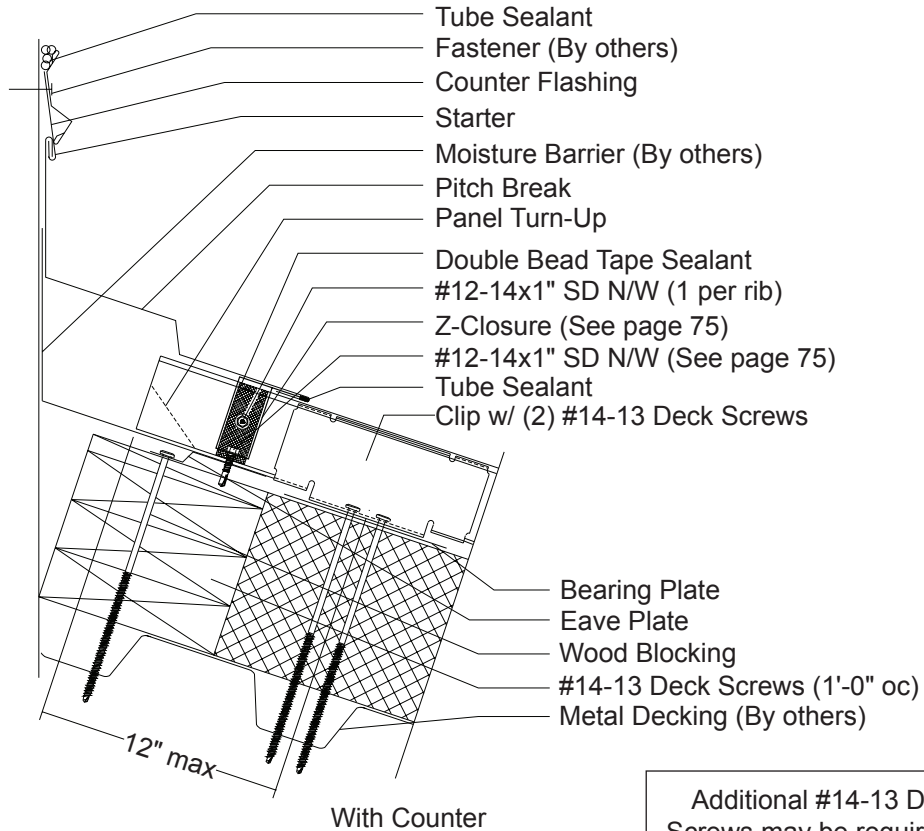

With Counter

Additional #14-13 Deck Screws may be required for areas with large snow loads.

Panel cap not shown for clarity.

INSTALLATION NOTES

1. Install Eave Plate and fasten through wood blocking and into metal deck with #14-13 Deck Screws at 1'-0" oc. If more than one Eave Plate is required then butt the ends together.
2. Place panels on to the Eave Plate and apply a row of Double Bead Tape Sealant across panel, up and over all ribs approximately 2" to 3" from panel end.
3. Field-cut Z-Closure to fit between the panel ribs, install Z-Closure over Tape Sealant. Before continuing make sure Z-Closure placement will accommodate Pitch Break.
4. Once Z-Closure is set in Tape Sealant, fasten through Z-Closure, Tape Sealant, T-Armor panel and into the Eave Plate with #12-14x1" Self Driller N/W screws (see page 75 for number and location of fasteners required).
5. Install Pitch Break by applying Double Bead Tape Sealant to the top of the Z-Closure and hooking the open hem around the Z-Closure. Fasten into the wall substrate with fasteners at 1'-0" oc maximum.
6. If two or more flashings are required, lap the flashing over the previously installed flashing by a minimum of 2" placing a bead of Tube Sealant between the flashings and secure with Pop Rivets, 2.5" oc.
7. Install Counter Flashing, Reglet, or wall panel and fasten to parapet wall with appropriate fastener, 1'-0" oc. If Counter Flashing or Reglet is used, seal at wall with Tube Sealant.

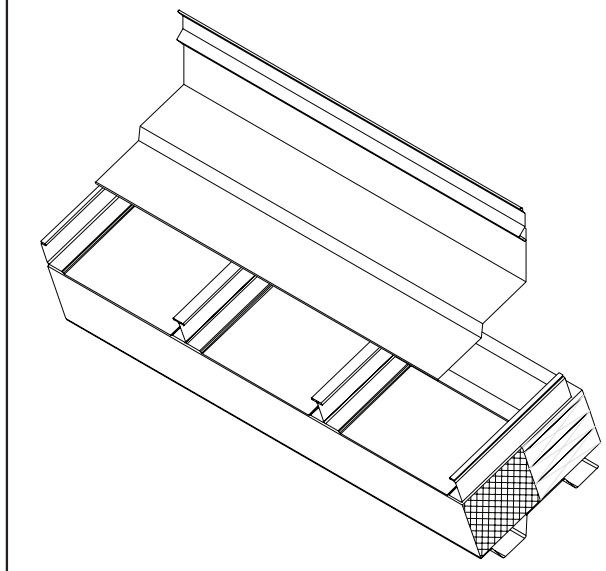

1/2:12 Slope
Minimum

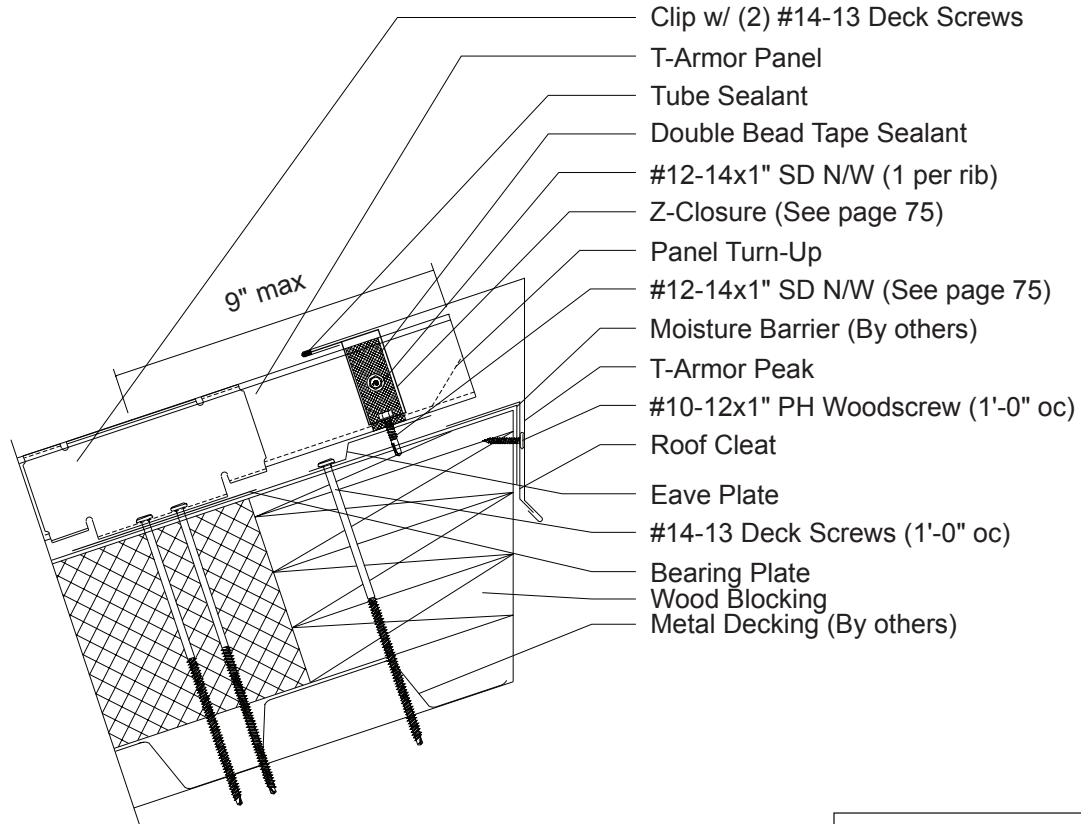

Panel cap not shown for clarity.

Additional #14-13 Deck
Screws may be required for
areas with large snow loads.

INSTALLATION NOTES

1. Install Roof Cleat and secure with #10-12x1" PH Wood Screws spaced 1'-0" oc.
2. Install Eave Plate and fasten into place with #14-13 Deck Screws at 1'-0" oc. If more than one Eave Plate is required then butt the ends together.
3. Place panels on the Eave Plate and apply a row of Double Bead Tape Sealant across panel, up and over all ribs approximately 2" to 3" from panel end.
4. Field-cut Z-Closure to fit between the panel ribs. Install Z-Closure over Tape Sealant. Before continuing, make sure Z-Closure placement will accommodate T-Armor Peak.
5. Once Z-Closure is set in Tape Sealant, fasten through Z-Closure, Tape Sealant, T-Armor panel and into the Eave Plate with #12-14x1" Self Driller N/W screws (see page 75 for number and location of fasteners required).
6. Apply Double Bead Tape Sealant on top of Z-Closure and install T-Armor Peak by hooking the open hem around the Z-Closure and engaging with Roof Cleat.
7. If two or more flashings are required, lap the flashing over the previously installed flashing by a minimum of 2" placing a bead of Tube Sealant between the flashings and secure with Pop Rivets, 2.5" oc.

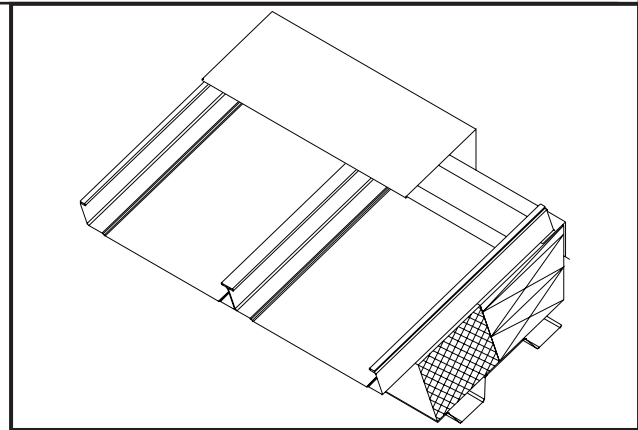

1/2:12 Slope
Minimum

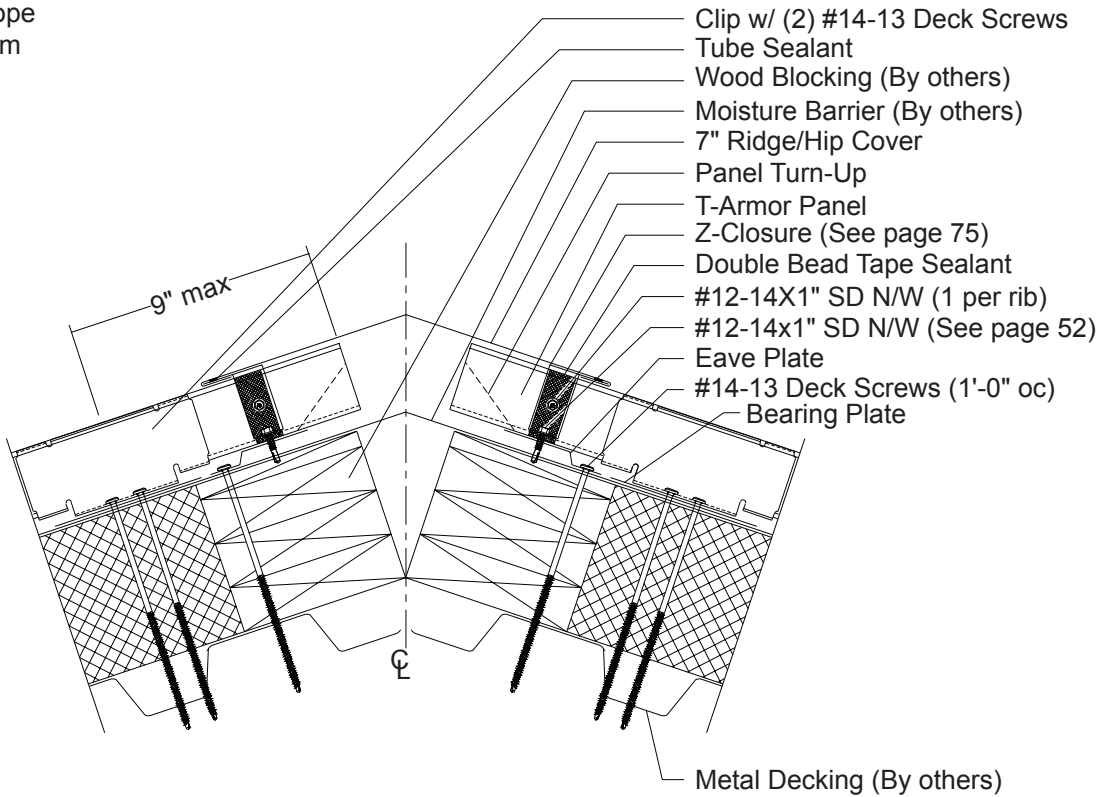

Panel cap not shown for clarity.

Additional #14-13 Deck Screws may be required for areas with large snow loads.

INSTALLATION NOTES

1. Install Eave Plate and fasten through the wood blocking into the metal deck with #14-13 Deck Screws at 1'-0" oc. If more than one Eave Plate is required then butt the ends together.
2. Place panels on to the Eave Plate and apply a row of Double Bead Tape Sealant across panel, up and over all ribs approximately 2" to 3" from panel end.
3. Field-cut Z-Closure to fit between the panel ribs, install Z-Closure over Tape Sealant. Before continuing, make sure Z-Closure placement will accommodate 7" Ridge/Hip Cover.
4. Once closure is set in Tape Sealant, fasten through Z-Closure, Tape Sealant, T-Armor panel and into the Eave Plate with #12-14x1" Self Driller N/W screws (see page 75 for number of fasteners required).
5. Install 7" Ridge/Hip Cover by applying a bead of Tube Sealant to the top of the Z-Closure, setting the flashing in place by hooking onto the Z-Closure.
6. If two or more flashings are required, lap the flashing over the previously installed flashing by a minimum of 2" placing a bead of Tube Sealant between the flashings and secure with Pop Rivets, 2.5" oc.

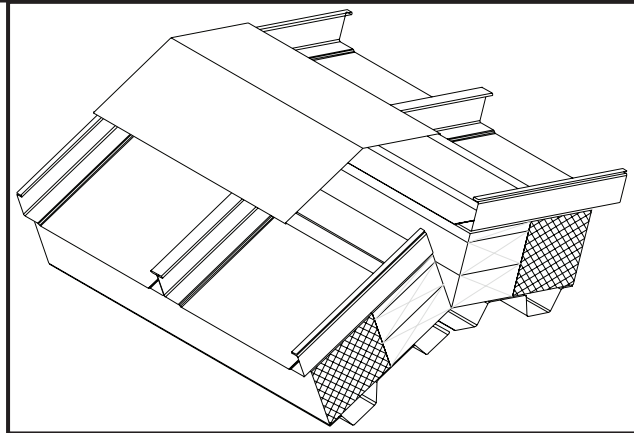

1/2:12 Slope
Minimum

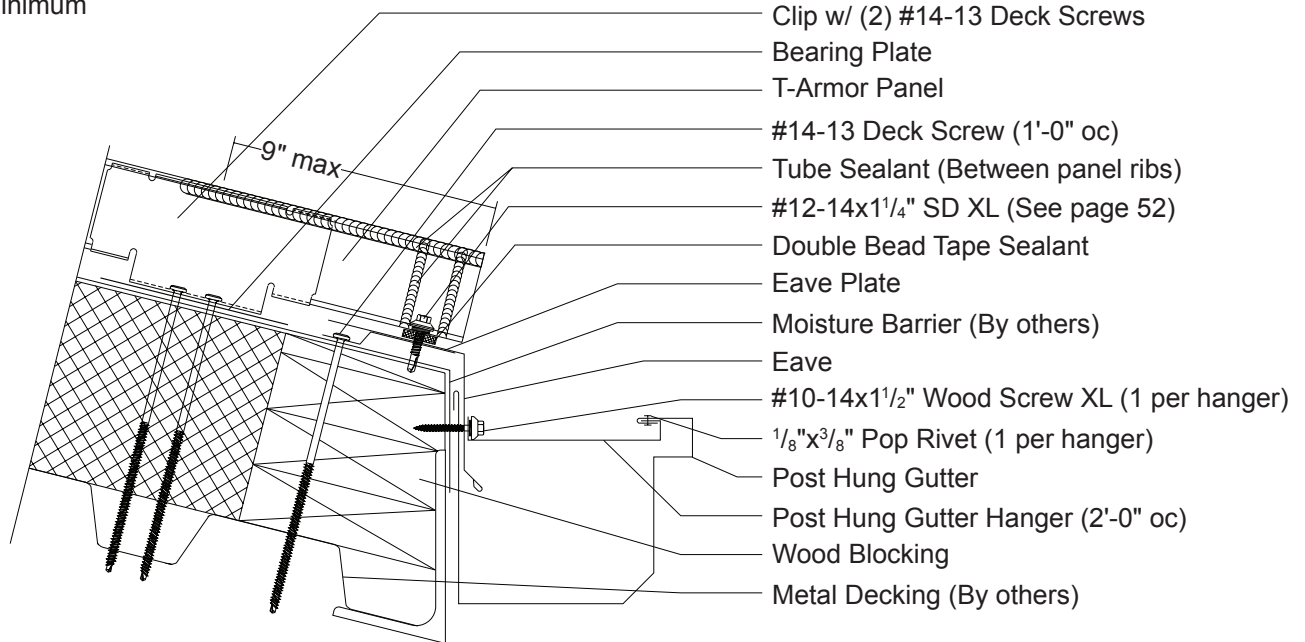

Panel cap not shown for clarity.

Additional #14-13 Deck Screws may be required for areas with large snow loads.

CAUTION

In locations where heavy rainfall or severe ice and snow may occur, Metal Sales standard gutters may not be suitable for use.

INSTALLATION NOTES

All Eave flashings must be installed prior to panel installation.

1. Install new Eave Plate over top of rigid board insulation and fasten through the wood blocking into the metal deck with #14-13 Deck Screws at 1'-0" oc.
2. Install new Eave flashing on top of the Eave Plate.
3. Apply a continuous row of Double Bead Tape Sealant across the top of the Eave flashing.
4. Set panel into place and use #12-14x1 1/4" Self Driller XL screws to fasten into place (see page 52).
5. Apply Tube Sealant up the side and across the top of the panel ribs before installing the next panel.
6. Install the Gutter by sliding it behind the Eave. Install the Post Hung Gutter Hangers at 2'-0" oc, fastening through the Eave into the roof framing.
7. If two or more flashings are required, lap the flashing over the previously installed flashing by a minimum of 2", place two beads of Tube Sealant between the flashings and secure with Pop Rivets, 2.5" oc.

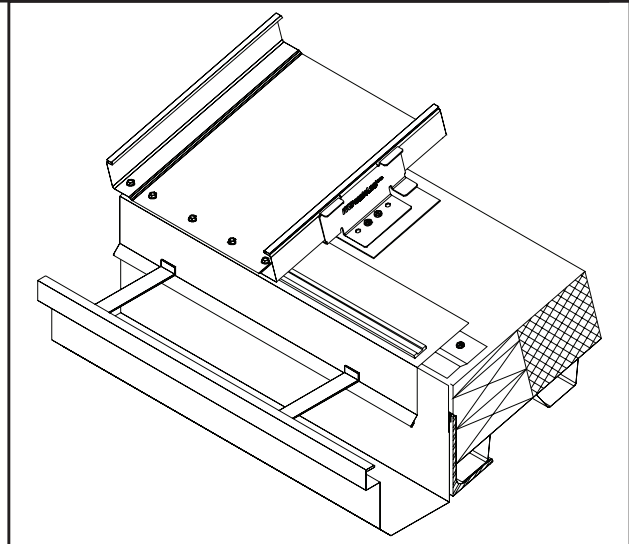

1/2:12 Slope
Minimum

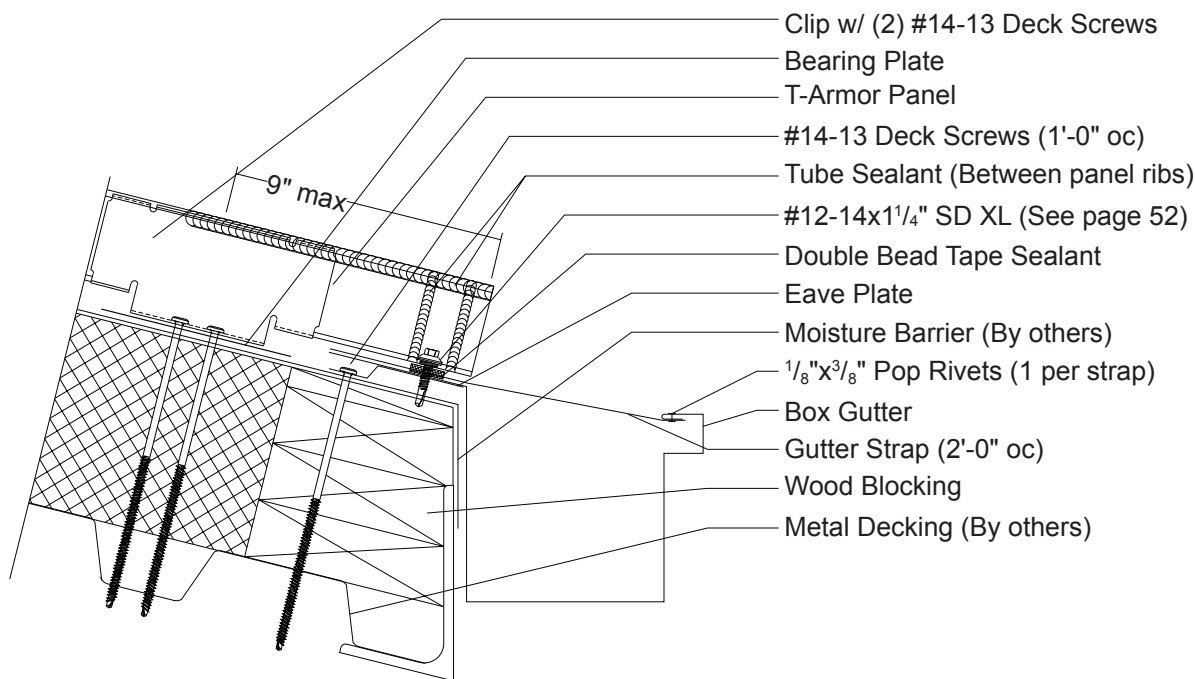

Panel cap not shown for clarity.

Additional #14-13 Deck Screws may be required for areas with large snow loads.

CAUTION

In locations where heavy rainfall or severe ice and snow may occur, Metal Sales standard gutters may not be suitable for use.

INSTALLATION NOTES

All Eave flashings must be installed prior to panel installation.

1. Install new Eave Plate over top of rigid board insulation and fasten through the wood blocking into the metal deck with #14-13 Deck Screws at 1'-0" oc.
2. Install new Box Gutter flashing on top of the Eave Plate.
3. If two or more flashings are required, lap the flashing over the previously installed flashing by a minimum of 2" placing two rows of Tube Sealant between the flashings and secure with Pop Rivets, 2.5" oc.
4. Apply a continuous row of Double Bead Tape Sealant across the top of the Eave flashing.
5. Place Gutter Straps into place at 2'-0" oc and fasten to the front of the Box Gutter with a 1/8"x3/8" Pop Rivet.
5. Set panel into place and use #12-14x1 1/4" Self Driller XL screws to fasten into place (see page 52).
6. Apply Tube Sealant up the side and across the top of the panel ribs before installing the next panel.

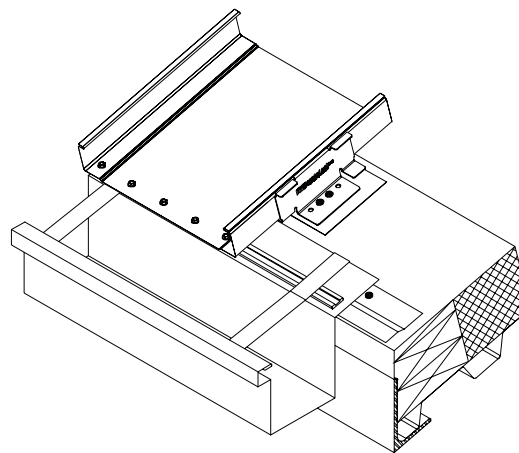

1/2:12 Slope
Minimum

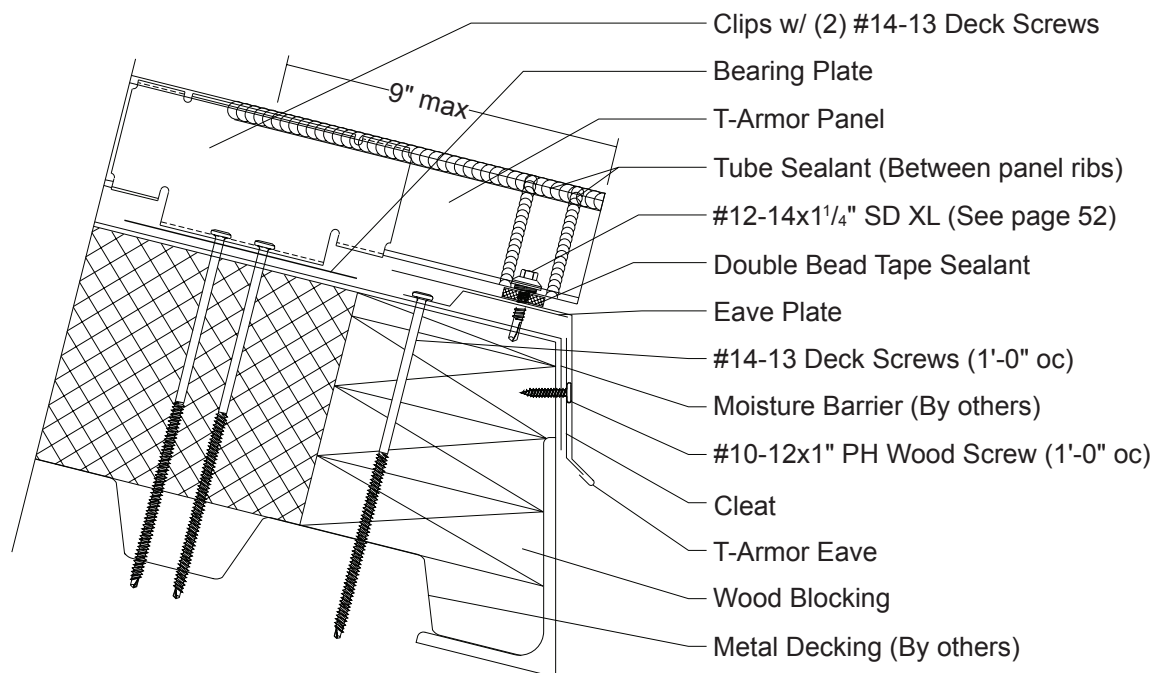

Panel cap not shown for clarity.

Additional #14-13 Deck Screws may be required for areas with large snow loads.

INSTALLATION NOTES

All eave flashings must be installed prior to panel installation.

1. Install Eave Plate over top of rigid board insulation and fasten through the wood blocking into the metal deck with #14-13 Deck Screws 1'-0" oc.
2. Install T-Armor Eave by engaging to Roof Cleat and rotating onto the Eave Plate.
3. If two or more flashings are required, lap the flashing over the previously installed flashing by a minimum of 2" placing two beads of Tube Sealant between the flashings and secure with Pop Rivets, 2.5" oc.
4. Apply a continuous row of Double Bead Tape Sealant across the top of the T-Armor Eave.
5. Set panel into place and use #12-14x1 1/4" Self Driller XL screws to attach (see page 52).
6. Apply Tube Sealant up the side and across the top of the panel ribs before installing the next panel.

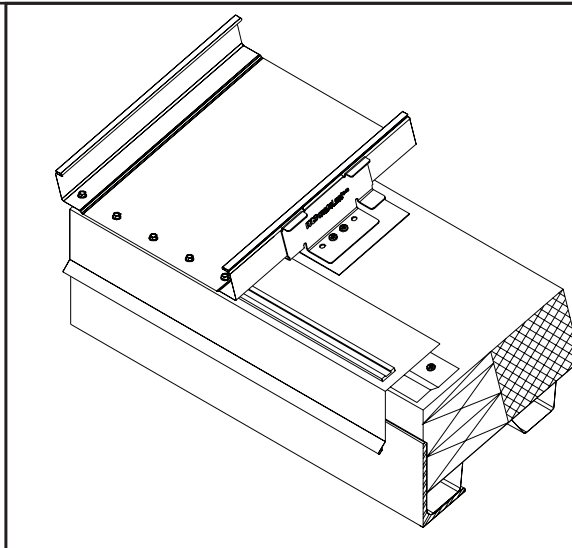

3:12 Slope
Minimum

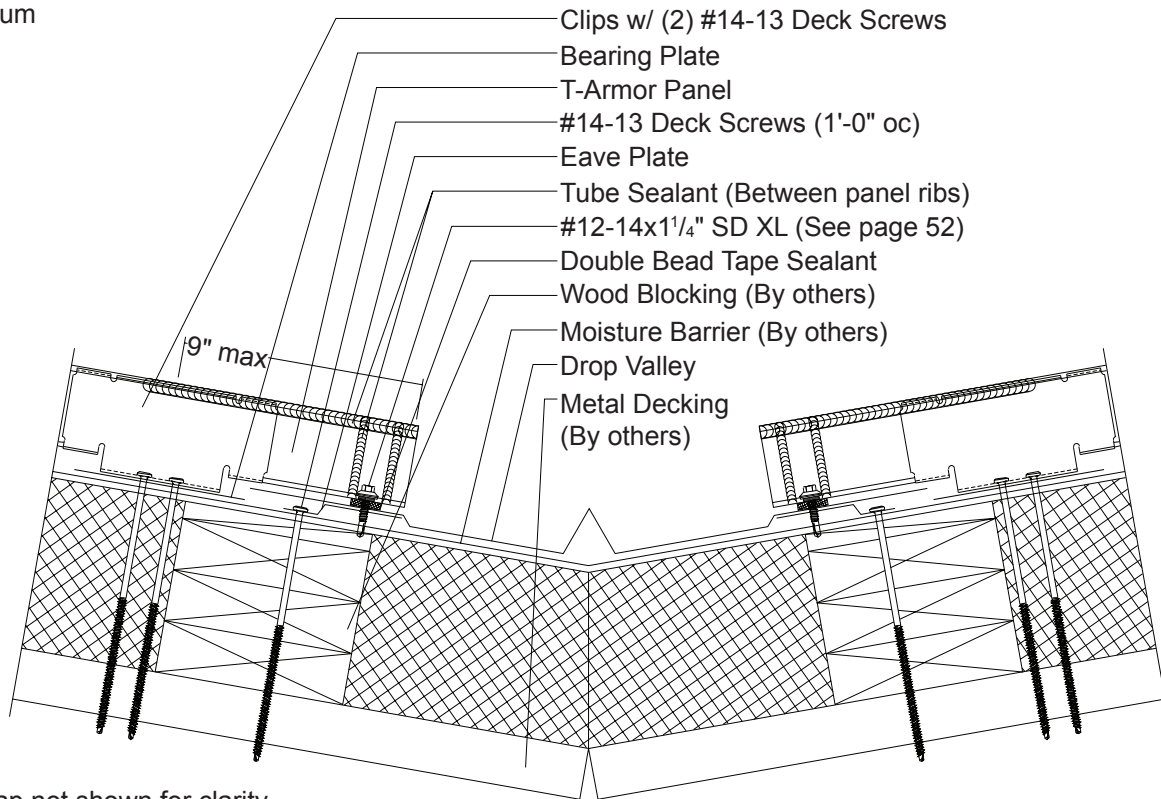

Panel cap not shown for clarity.

Additional #14-13 Deck Screws may be required for areas with large snow loads.

INSTALLATION NOTES

All Eave and Drop Valley flashings must be installed prior to panel installation.

1. Install new Eave Plate over top of rigid board insulation and fasten through the Valley Plate and wood blocking into the metal deck at 1'-0" oc.
2. Install new Drop Valley flashing on top of the Eave Plate.
3. If two or more flashings are required, lap the flashing over the previously installed flashing by a minimum of 6", placing two beads of Tube Sealant between the flashings. Locate beads of Tube Sealant so that it does not press out of the lap. Do not install fasteners through the Drop Valley lap.
4. Apply a continuous row of Double Bead Tape Sealant across the top of each side of the Drop Valley flashing.
5. Set panel into place and use #12-14x1 1/4" Self Driller XL screws to attach (see page 52).
6. Apply Tube Sealant up the side and across the top of the panel ribs before installing the next panel.

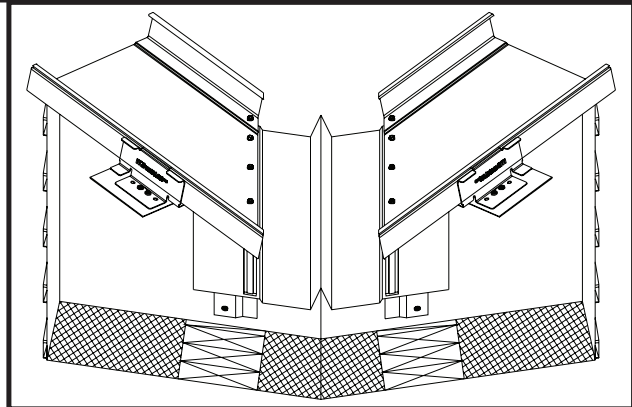

1/2:12 Slope
Minimum

With Reglet

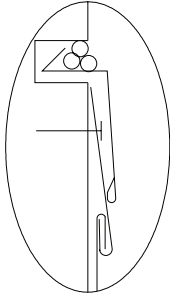

With Counter Flashing

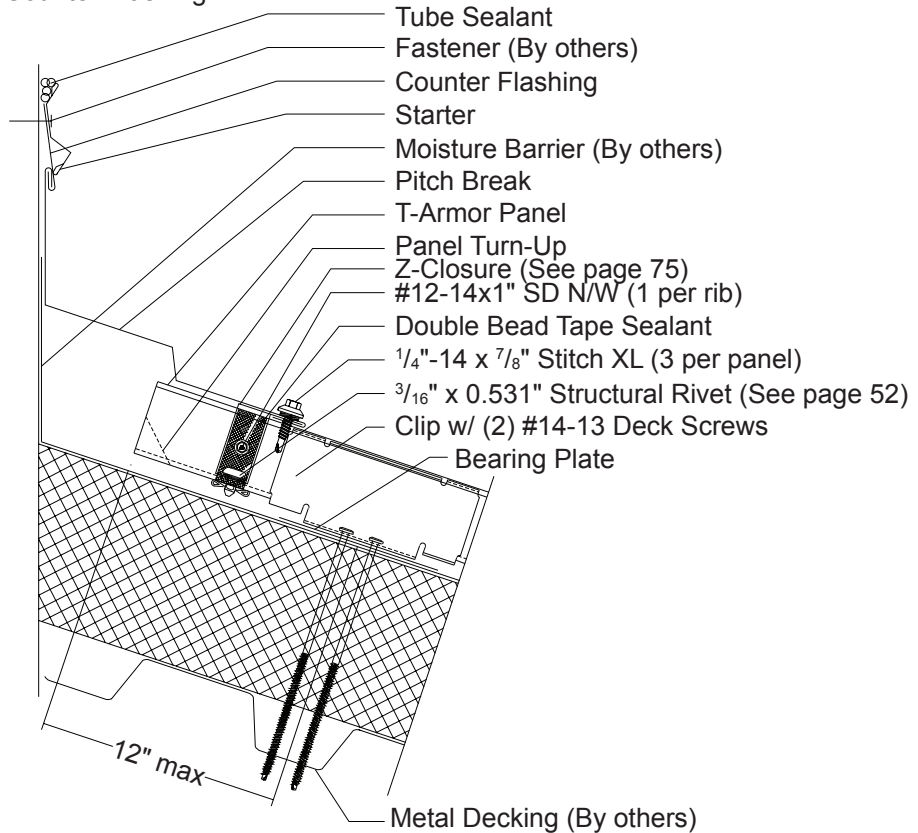

Panel cap not shown for clarity.

This detail can only be used with the low and high clip systems.

INSTALLATION NOTES

1. Once panels have been installed, apply a row of Double Bead Tape Sealant across panel, up and over all ribs approximately 2" to 3" from panel end.
2. Field-cut Z-Closure to fit between the panel ribs, install Z-Closure over Tape Sealant. Before continuing, make sure Z-Closure placement will accommodate Pitch Break.
3. Once closure is set in Tape Sealant, fasten through Z-Closure, Tape Sealant and T-Armor panel with 3/16" x 0.531" Structural Rivets and one #12-14x1" Self Driller N/W screw (see page 52 for number of fasteners required).
4. Apply a row of Double Bead Tape Sealant to the top of the Z-Closure.
5. Install Pitch Break by hooking the open hem around the Z-Closure, and fasten into the wall substrate with fasteners at 1'-0" oc maximum.
6. If two or more flashings are required, lap the flashing over the previously installed flashing by a minimum of 2" placing a bead of Tube Sealant between the flashings and secure with Pop Rivets, 2.5" oc.
7. Install Counter Flashing, Reglet or wall panel and fasten to parapet wall with appropriate fastener, 1'-0" oc. Seal to Counter Flashing, Reglet or parapet wall with Tube Sealant.

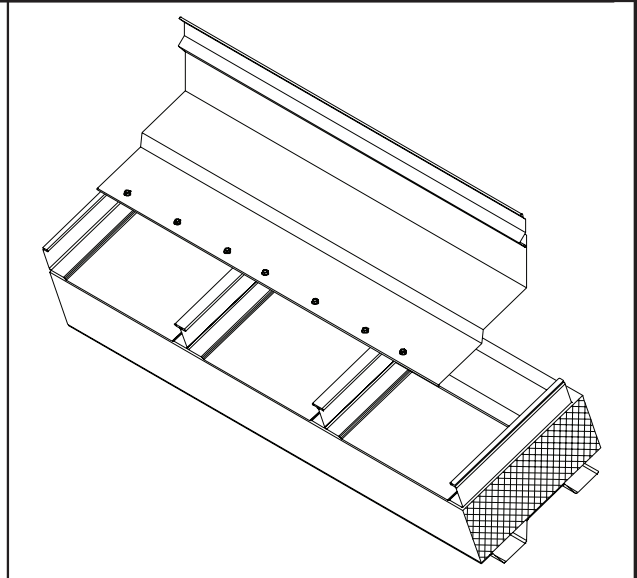

1/2:12 Slope
Minimum

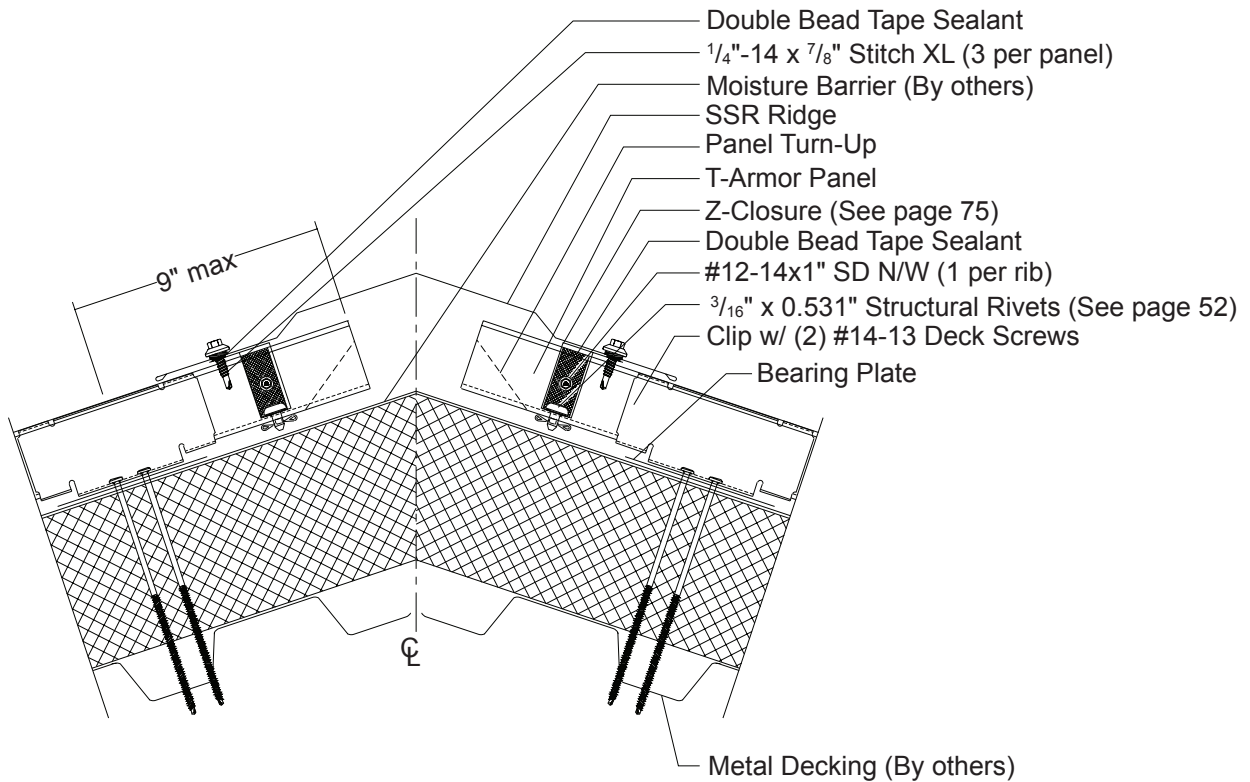

Panel cap not shown for clarity.

This detail can only be used with the low and high clip systems.

INSTALLATION NOTES

1. Once panels have been installed, apply a row of Double Bead Tape Sealant across panel, up and over all ribs approximately 2" to 3" from panel end.
2. Field-cut Z-Closure to fit between the panel ribs, install Z-Closure over Tape Sealant. Before continuing, make sure Z-Closure placement will accommodate SSR Ridge flashing.
3. Once Z-Closure is set in Tape Sealant, fasten through Z-Closure, Tape Sealant and T-Armor panel with 3/16" x 0.531" Structural Rivets and one #12-14x1" Self Driller N/W screw in the rib (see page 52 for number of fasteners required).
4. Install SSR Ridge flashing by applying Double Bead Tape Sealant to the top of the Z-Closures, locating the SSR Ridge and securing with 3 Pop Rivets per panel.
5. If two or more flashings are required, lap the flashing over the previously installed flashing by a minimum of 2" placing a bead of Tube Sealant between the flashings and secure with Pop Rivets, 2.5" oc.

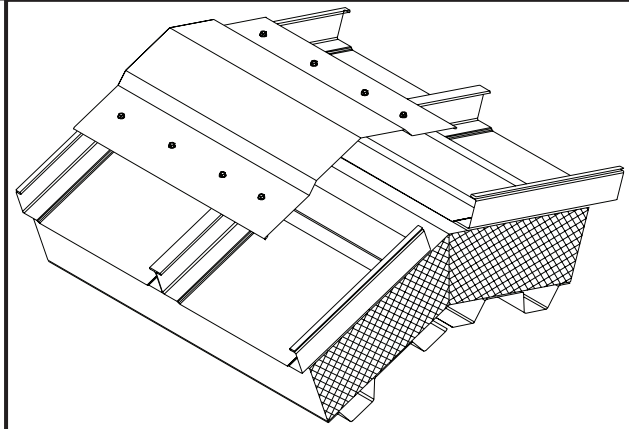

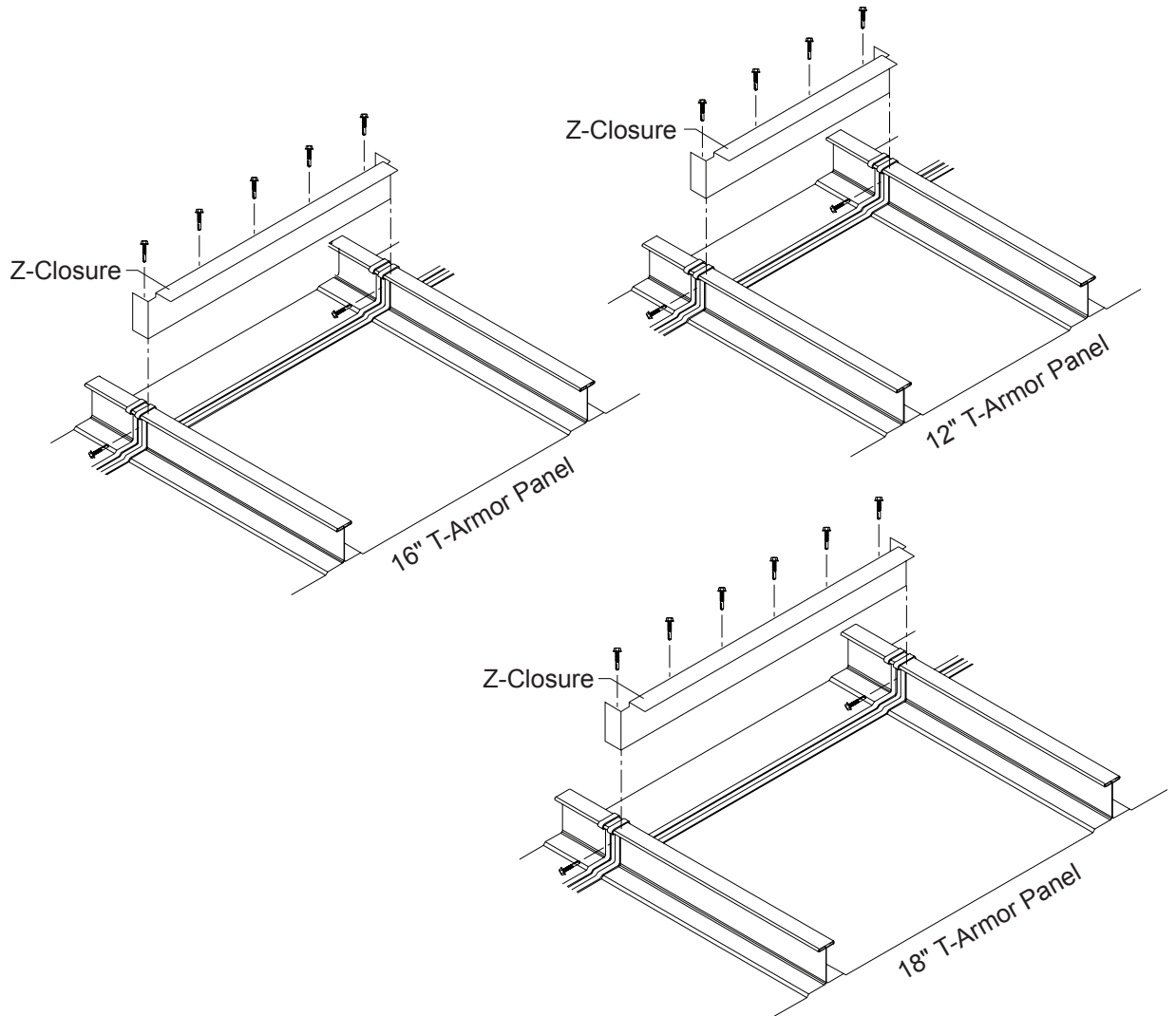

INSTALLATION NOTES

Panel Cap must be installed and hand crimped into place before the Z-Closure can be installed.

1. Place a row of Double Bead Tape Sealant across panel and over each rib approximately 4" to 6" from panel end. Before proceeding, make sure Z-Closure placement will accommodate flashing.
2. Field-cut the Z-Closure 2" longer than the panel width. Snip the top and bottom leg of the Z-Closure and bend both sides back (as shown above). Field-notch Z-Closure end to fit under panel rib and cap.
3. Fasten through the Z-Closure, Tape Sealant, T-Armor panel and substrate with appropriate fasteners.
4. Use a #12-14x1" Self Driller N/W screw to fasten through the side of panel rib, Tape Sealant and Z-Closure. See page 52 for fastener locations.

PANEL HEMMING

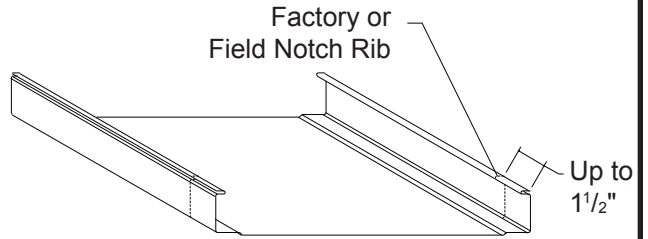
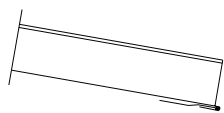
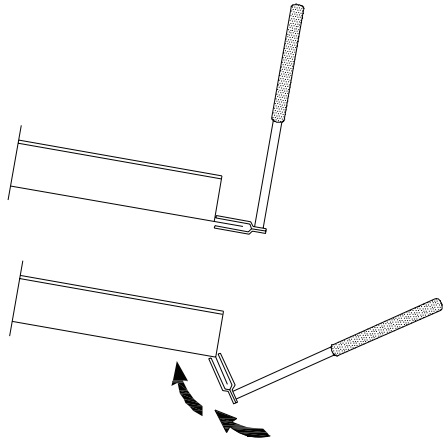
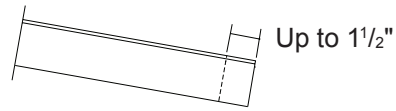

Field-bend flat part of panel to accept Offset Cleat

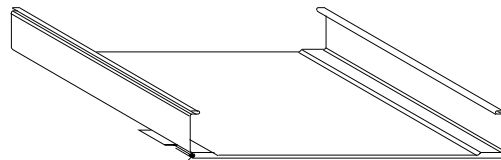
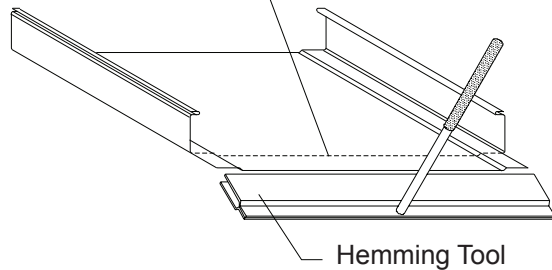

Field-apply Tube Sealant in hem and insert Offset Cleat

PANEL TURN-UP

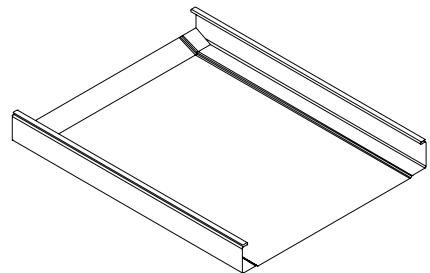
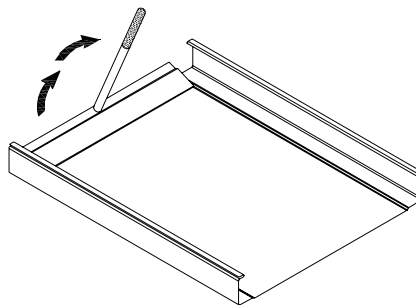
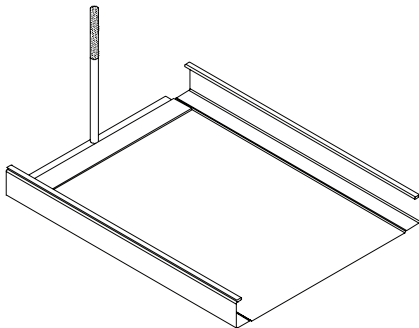

Note: See page 15 to associate panel with correct hemming/turn-up tool.

Z-CLOSURE BEND

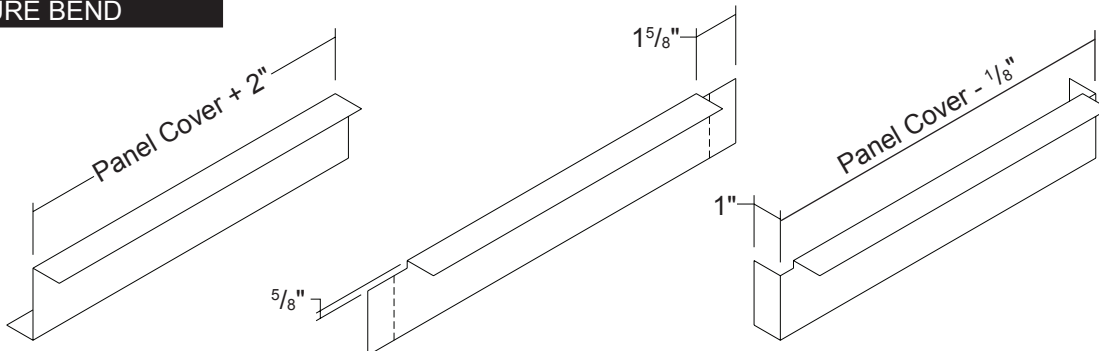

ROOF PENETRATIONS

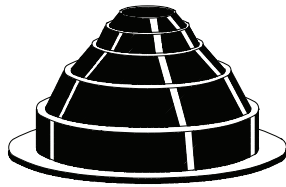

- Mini (1/4" to 1 1/8" O.D. Pipe)
- #2 (1 3/4" to 3" O.D. Pipe)
- #4 (3" to 6" O.D. Pipe)
- #6 (6" to 9" O.D. Pipe)
- #8 (7" to 13" O.D. Pipe)

Temperature Range: -30° to +250°

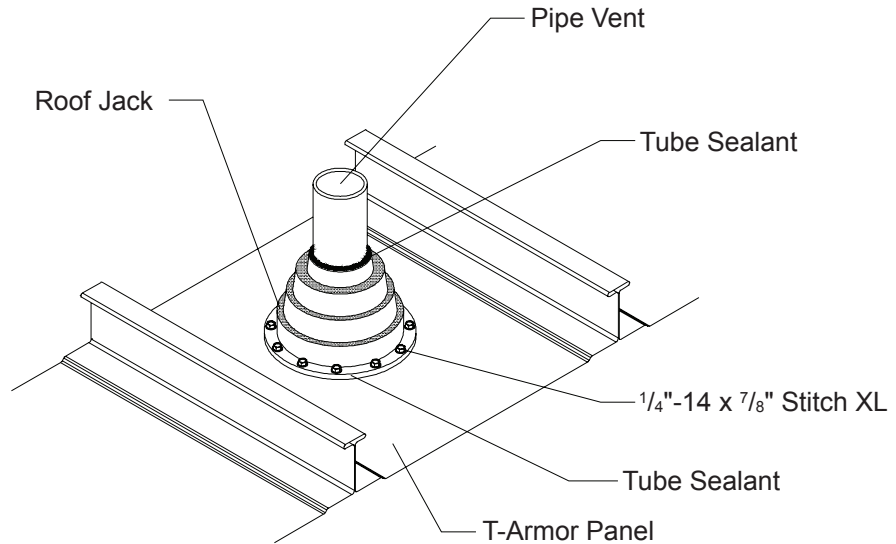

GENERAL NOTES

Size and location of all roof penetrations should be an important consideration. Areas around roof vents or rooftop units may show that corrosive fumes are emitted from a process within the building.

INSTALLATION NOTES

NOTE: The following procedures are for vent pipes 6" or less and not transmitting extremely hot or caustic materials. When installing vent pipes abide by the local plumbing codes.

1. Determine the size and length of the vent pipe to be raised.
2. Take the appropriate measurements for the vent location and mark them on the T-Armor panel. The vent pipe must extend through the flat of the roof panel. If the vent pipe extension cannot be raised directly into the flat of the new roof panel, elbows should be used to offset the pipe. Cut the panel to fit the vent pipe properly.
3. Use a light gauge angle to secure and plumb the vent pipe to the framing system.
4. Flash the vent pipe with a Rubber Roof Jack or similar pipe flashing.
5. Apply Tube Sealant between the panel and the base of the Rubber Roof Jack as well as the top where the boot meets the pipe.
6. Attach the base of the Rubber Roof Jack to the panel using 1/4"-14 x 7/8" Stitch XL fasteners.

FLASHING LAPS

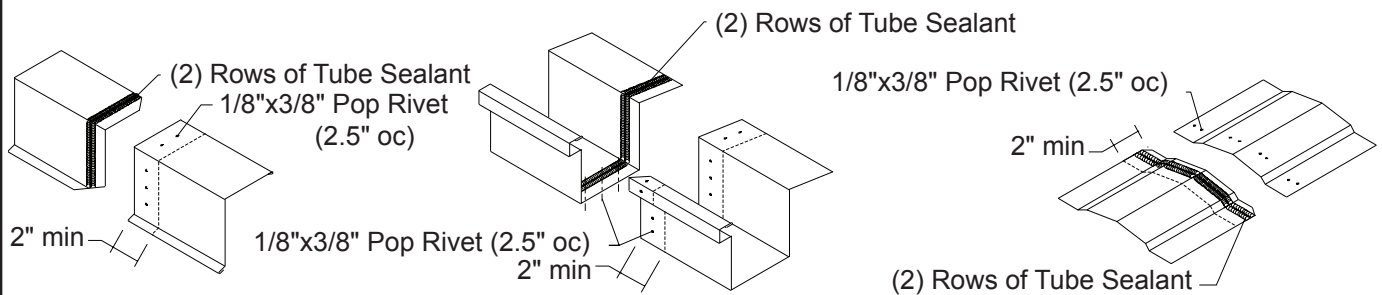

Though factory-applied, prepainted finishes are very durable and will last many years, eventually it may be desirable to thoroughly clean or repaint them.

Dirt accumulation may cause apparent discoloration of the paint when it has been exposed in some dirt laden atmospheres for long periods of time. In areas of strong sunlight, slight chalking may cause some change in appearance. A good cleaning will often restore the appearance of these buildings and render repainting unnecessary. An occasional light cleaning will help maintain a good appearance.

In many cases, simply washing the building with plain water using a hose or pressure sprayer will be adequate. In areas where heavy dirt deposits dull the surface, a cloth or soft bristle brush and solution of water and detergent ($\frac{1}{3}$ cup of laundry detergent per gallon of water for example) may be used. This should be followed by an adequate rinse of water. Do not use wire brushes, abrasives or cleaning tools which will damage the coating surface.

Mildew may occur in areas subject to high humidity but is not normally a problem due to the high inherent mildew resistance of the baked finish that is used. However, mildew can grow on dirt and spore deposits in some cases. To remove mildew along with the dirt, the following solution is recommended.

- $\frac{1}{3}$ cup detergent (Tide® or equivalent)
- $\frac{2}{3}$ cup trisodium phosphate (Solex® or equivalent)
- 1 quart of 5% sodium hypochlorite solution (Clorox® or equivalent)
- 3 quarts of water

Strong solvents and abrasive type cleaners should be avoided. Most organic solvents are flammable and toxic, and must be handled accordingly. When using a solvent, consult maintenance professionals and label instructions for proper handling and disposal of washings. If required, a mild solvent such as mineral spirits can be used to remove caulking compounds, oil, grease, tars, wax and similar substances. Use a cloth dampened with mineral spirits and apply only to areas which are contaminated. Follow up the use of this mild solvent with detergent cleaning and rinsing.



DO NOT USE A
WIRE BRUSH

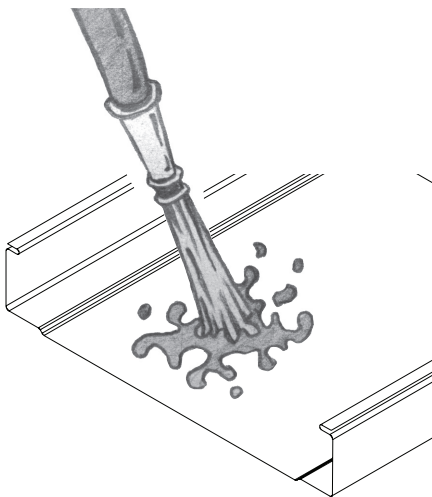

HOSE OR PRESSURE SPRAY
FOR ADEQUATE CLEANING



USE MILD DETERGENT AND WATER
FOR HEAVY DIRT DEPOSITS

PANEL REPLACEMENT PROCEDURE

Steps:

1) Remove Trims

Any trims that attach to the damaged panel must be removed or the fasteners that attach to the panel and the trim must be removed. Typical trims that must be addressed include: Ridge, Hip, Peak, Eave, Endwall, Sidewall and Roof Penetrations. The end fasteners, including the horizontal fastener, and the Z-Closure at the high end of the panel must be removed.

2) Remove Caps

The caps on each side of the damaged panel must be removed. In addition to renting seaming machines, DI also rents a De-Seaming machine that will remove a seamed-on cap. The caps can be removed manually with a screw driver to open the end of the cap and a pry bar to lift the cap off of the panel. Care must be taken to avoid damaging the panels if the caps are removed manually.

3) Remove Damaged Panel

After removing all attachments to the damaged panel, pull the hem at the top of the panel off of the panel clips and lift one side of the panel out of its place. A pair of locking pliers can be an effective tool for taking hold of the panel hem. If the panel is hemmed at the low end, sliding the panel downslope will allow the panel to be removed. For stiff panels (ex. 12" wide, 20 ga panels), it may be necessary to rip the panel by cutting it in the flat from low end to high end with power shears or nibblers.

Once the damaged panel is removed, check the exposed clips, fasteners, Offset Cleat at eave for damage and replace any damaged components.

4) Install New Panel

Place the hem on one side of the replacement panel on the clips. If the eave-end of the panel is hemmed, slide the panel on to the Offset Cleat before engaging the hem on the other side of the panel. If the panel contains an endlap, then install the lowest panel first, working up slope.

5) Install New Caps

Before installing the new caps on each side of the replaced panels, remove any sealant that remains on the adjacent, non-damaged panels. Install the new caps starting at the low end and working upslope.

6) Install Trims

Before reinstalling the trims, inspect them to see whether they should be replaced due to damage. Sealant that remains on the trims should be removed and replaced. New fasteners should be used, rather than reusing the original fasteners.

Ordering Parts:

Order panels taking into account the additional length that may be needed at eave hem or endlaps.

Order one more cap than the number of panels, of comparable lengths.

Order parts for endlaps, including Stiffening Plates, sealant and fasteners.

Order replacement trims and fasteners.

Rent a Power Seamer, Hand Crimper and Power DeSeamer.

