



Installation Guide
PBR-PANEL

metalsales.us.com

The application and detail drawings in this manual are strictly for illustration purposes and may not be applicable to all building designs or product installations. All projects should conform to applicable building codes for that particular area. It is recommended to follow all building regulations and standard industry practices.

Metal Sales Manufacturing Corporation is not responsible for the performance of the roof system if it is not installed in accordance with the suggested instructions referenced in this manual. If there is a conflict between this manual and the approved Metal Sales' erection drawings, the approved erection drawings are to take precedence.

Prior to ordering and installing materials, all dimensions should be verified by field measurements.

Oil canning is not a cause for rejection. Oil canning can be described as the amount of waviness found in the flat areas of metal panels. Oil canning is an inherent characteristic of light gauge cold formed metal products, particularly those with broad flat areas. There are many factors which may contribute to oil canning that Metal Sales is not able to control. These factors include: misalignment of the support system, over driving of fasteners used on the panels, stress (whether inherent in the panel or induced), thermal expansion and contraction of the panel, material handling, width, gauge, length, color of panels and installation. (Reference Metal Construction Association "Oil Canning Position Paper" - Appendix A).

Metal Sales reserves the right to modify, without notice, any details, recommendations or suggestions. Any questions you may have regarding proper installation of PBR-Panels should be directed to your Metal Sales representative, (see pages 2 and 3).

Consult Metal Sales for any additional information not outlined in this manual.

This manual is designed to be utilized as a guide when installing PBR-Panels. It is the responsibility of the erector to ensure the safe installation of this product system.

SAFETY

STUDY APPLICABLE OSHA AND OTHER SAFETY REQUIREMENTS BEFORE FOLLOWING THESE INSTRUCTIONS.

The installation of metal roof systems is a dangerous procedure and should be supervised by trained knowledgeable erectors. **USE EXTREME CARE WHILE INSTALLING ROOF PANELS.** It is not possible for Metal Sales to be aware of all the possible job site situations that could cause an unsafe condition to exist. The erector of the roof system is responsible for reading these instructions and determining the safest way to install the roof system.

These instructions are provided only as a guide to show a knowledgeable, trained erector the correct parts placement one to another. If following any of the installation steps would endanger a worker, the erector should stop work and decide upon a corrective action.

Provide required safety railing, netting, or safety lines for crew members working on the roof.

Do not use the roof panel as a walking platform. The roof panels will not withstand the weight of a person standing at the edge of the panel.

Do not stand on any part of a roof panel until the panel has been completely attached.

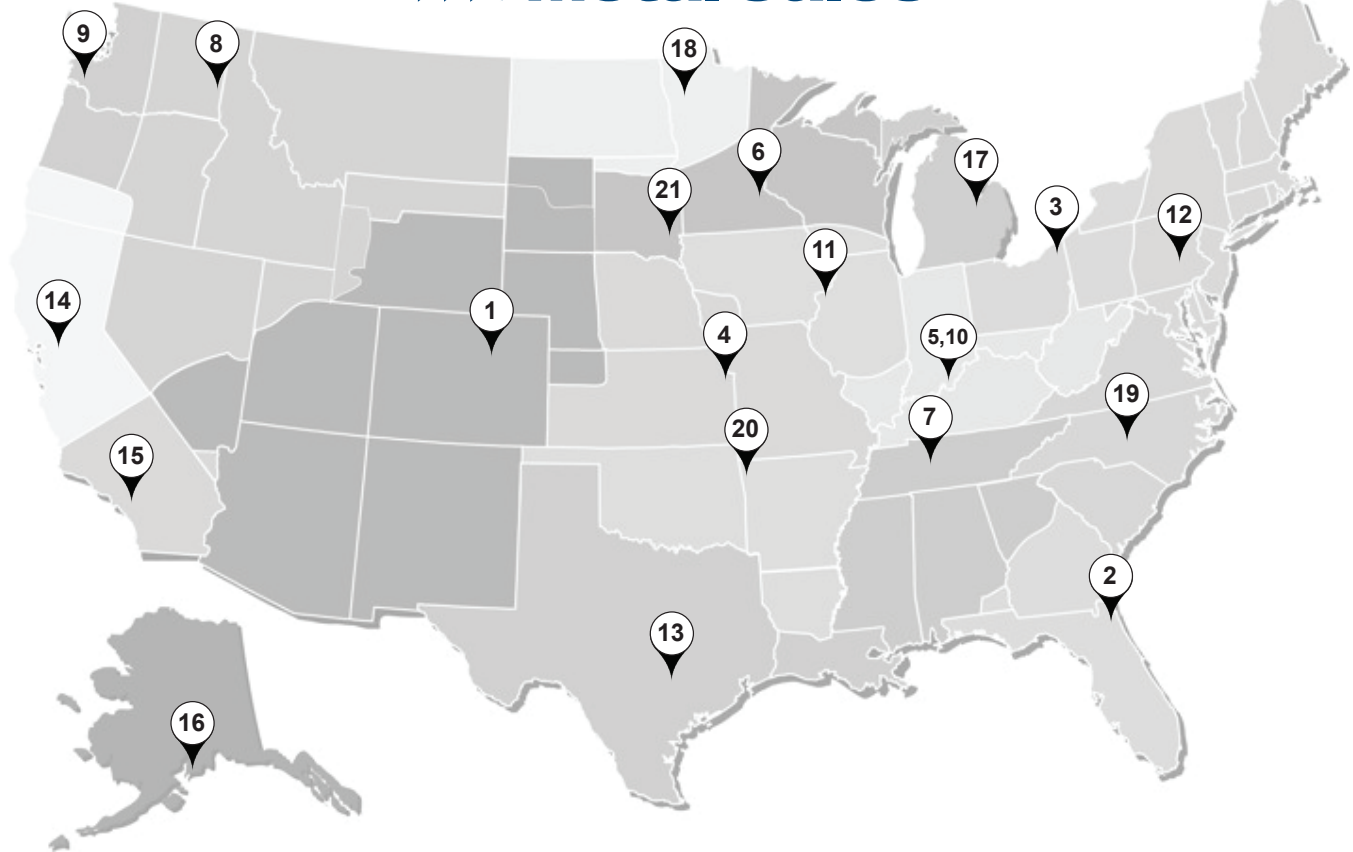

NOTE: Shaded areas represent territories served by each location.

MANUFACTURING BRANCHES ■ PBR-PANEL • R-PANEL

<p>1 Denver, CO PBR-Panel R-Panel</p>	<p>2 Jacksonville, FL PBR-Panel</p>	<p>3 Jefferson, OH PBR-Panel R-Panel</p>	<p>4 Independence, MO PBR-Panel</p>
<p>5 Sellersburg, IN PBR-Panel R-Panel</p>	<p>6 Rogers, MN PBR-Panel R-Panel</p>	<p>7 Nashville, TN PBR-Panel R-Panel</p>	<p>8 Spokane, WA PBR-Panel R-Panel</p>
<p>11 Rock Island, IL PBR-Panel</p>	<p>12 Deer Lake, PA PBR-Panel R-Panel</p>	<p>13 Temple, TX PBR-Panel R-Panel</p>	<p>14 Woodland, CA PBR-Panel R-Panel</p>
<p>15 Fontana, CA PBR-Panel R-Panel</p>	<p>17 Bay City, MI PBR-Panel</p>	<p>19 Mocksville, NC PBR-Panel R-Panel</p>	<p>20 Fort Smith, AR PBR-Panel R-Panel</p>

1. DENVER

7990 East I-25 Frontage Road
Longmont, CO 80504
303.702.5440
800.289.7663
800.289.1617 Fax

2. JACKSONVILLE

7110 Stuart Avenue
Jacksonville, FL 32254
904.783.3660
800.394.4419
904.783.9175 Fax
800.413.3292 Fax

3. JEFFERSON

352 East Erie Street
Jefferson, OH 44047
440.576.9070
800.321.5833
440.576.9242 Fax
800.233.5719 Fax

4. INDEPENDENCE

1306 South Powell Road
Independence, MO 64057
816.796.0900
800.747.0012
816.796.0906 Fax

5. SELLERSBURG

7800 Highway 60
Sellersburg, IN 47172
812.246.1866
800.999.7777
812.246.0893 Fax
800.477.9318 Fax

6. ROGERS

22651 Industrial Boulevard
Rogers, MN 55374
763.428.8080
800.328.9316
763.428.8525 Fax
800.938.9119 Fax

7. NASHVILLE

4314 Hurricane Creek Boulevard
Antioch, TN 37013
615.641.7100
800.251.8508
615.641.7118 Fax
800.419.4372 Fax

8. SPOKANE

2727 East Trent Avenue
Spokane, WA 99202
509.536.6000
800.572.6565
509.534.4427 Fax

9. KELSO

2680 Coweeman Park Drive
Kelso, WA 98626
253.872.5750
800.431.3470
253.872.2008 Fax

10. NEW ALBANY

999 Park Place
New Albany, IN 47150
812.944.2733
812.944.1418 Fax

11. ROCK ISLAND

8111 West 29th Street
Rock Island, IL 61201
309.787.1200
800.747.1206
309.787.1833 Fax

12. DEER LAKE

29 Pinedale Industrial Road
Orwigsburg, PA 17961
570.366.2020
800.544.2577
570.366.1648 Fax
800.544.2574 Fax

13. TEMPLE

3838 North General Bruce Drive
Temple, TX 76501
254.791.6650
800.543.4415
254.791.6655 Fax
800.543.4473 Fax

14. WOODLAND

1326 Paddock Place
Woodland, CA 95776
530.668.5690
800.759.6019
530.668.0901 Fax

15. FONTANA

14213 Whittram Avenue
Fontana, CA 92335
909.829.8618
800.782.7953
909.829.9083 Fax

16. ANCHORAGE

4637 Old Seward Highway
Anchorage, AK 99503
907.646.7663
866.640.7663
907.646.7664 Fax

17. BAY CITY

5209 Mackinaw Road
Bay City, MI 48706
989.686.5879
888.777.7640
989.686.5870 Fax
888.777.0112 Fax

18. DETROIT LAKES

1435 Egret Avenue
Detroit Lakes, MN 56501
218.847.2988
888.594.1394
218.847.4835 Fax
888.594.1454 Fax

19. MOCKSVILLE

188 Quality Drive
Mocksville, NC 27028
336.751.6381
800.228.6119
336.751.6301 Fax
800.228.7916 Fax

20. FORT SMITH

7510 Ball Road
Fort Smith, AR 72908
479.646.1176
877.452.3915
479.646.5204 Fax

21. SIOUX FALLS

2700 West 3rd Street, Suite 4
Sioux Falls, SD 57104
605.335.2745
888.299.0024

CORPORATE OFFICE

7800 Highway 60
Sellersburg, IN 47172
800.406.7387
800.944.6884 Fax

TECHNICAL SUPPORT

TECH SERVICES DEPT.
7800 Highway 60
Sellersburg, IN 47172
502.855.4300
800.406.7387
800.944.6884 Fax

General Information	PAGE NUMBER
Important Information	1
Branch Territory Map/Manufacturing Branches	2
Branch Locations.....	3
Table of Contents	4-5
Panel Profiles	
PBR-Panel Profile.....	6
R-Panel Profile	7
PBR-Panel Reverse-Roll Profile.....	8
R-Panel Reverse-Roll Profile.....	9
Flashing Profiles.....	10-21
Accessory Profiles	22-25
Fasteners.....	26
Fastener Technical Information	
Physical Properties.....	27
Pull Out Strength Values	28
Pull Over Strength Values	29
Design Information	
PBR-Panel.....	30-31
R-Panel.....	32-33
UL 580 Wind Uplift Information	34
General Instructions/Expansion & Contraction.....	35
Handling Material	
Receiving Material	36
General Handling.....	36
Mechanical Handling	36
Manual Handling.....	37
Storage	
General.....	38
Foot Traffic.....	38
Required Tools.....	38
Roof Preparation	39
Field Cutting and Touch-up	
Field Cutting	40
Touch-up Paint	40
Ventilation	40

	PAGE NUMBER
Care and Maintenance	41
Table of Contents - Details	42
ms-HT Installation.....	43
Eave	44
Extended Eave	45
Box Gutter	46
Valley	47
Panel Installation	48-49
Endlap Detail	50
Endlap Installation	51
Light Transmitting Panel.....	52
Rubber Roof Jack.....	53
Formed Ridge.....	54
Ridge/Hip.....	55
Universal Ridge	55
Vented Ridge	56
LP2 Vented Ridge.....	57
Rakewall.....	58
Endwall.....	59
Sculptured Rake	60
Rake	61
Sculptured Peak.....	62
Sculptured Gutter	63
PBR Outside Corner.....	64
PBR Inside Corner.....	65
Outside Corner	66
Inside Corner	67
Jamb.....	68
Base	69
Sill/Head	70
Sill to Soffit.....	71
Head Channel.....	72
Wainscotting – Double Angle	73

PBR-PANEL

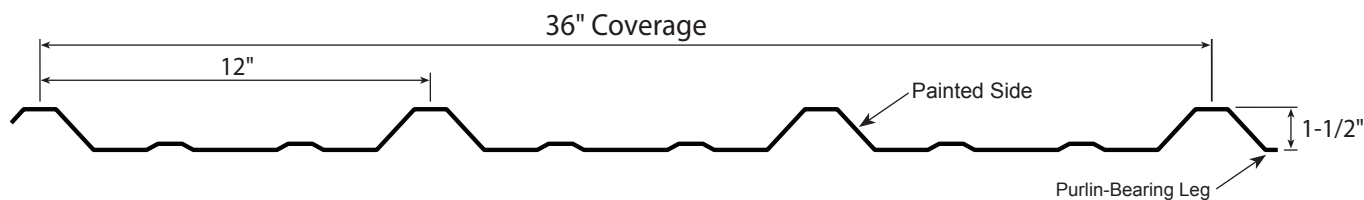

Profile	Product No.	Coverage	Gauge	Finish
	2505241	36"	26	Acrylic-Coated Galvalume® (ACG)
	25052XX	36"	26	MS Colorfast45
	26052XX	36"	26	PVDF Painted
	2705241	36"	24	Acrylic-Coated Galvalume® (ACG)
	28052XX	36"	24	PVDF Painted
	2905241	36"	22	Acrylic-Coated Galvalume® (ACG)
	29052XX	36"	22	PVDF Painted

Roof Slope
 The minimum recommended slope for any PBR-Panel is 1:12.
 Metal Sales recommends that in all roof applications sealant be used on sidelaps.

Length
 Lengths under 5'-0" are available with some cutting restrictions.
 Maximum recommended panel length is 45'-0".
 Longer panels require additional consideration in packaging, shipping, and erection.
 Please consult your Metal Sales branch for recommendations.

Fasteners
 The fastener selection guide should be consulted for choosing proper fasteners for specific applications. Quantity and type of fastener must meet necessary loading and code requirements (see PGI-12-14).

Materials
 Steel grade 50 per ASTM A 792 (24 and 22 gauge)
 Steel grade 80 per ASTM A 792 or ASTM A 653 (26 gauge)

Finish
 Acrylic Coated Galvalume® (ACG) / ASTM A792 - AZ55
 Pre-painted Galvalume / ASTM A792 - AZ50
 MS Colorfast45® (SMP)
 PVDF (Kynar 500 or Hylar 5000®)
 Differential appearance of Acrylic Coated Galvalume roofing materials is not a cause for rejection.

Support Materials
 Steel Framing – 16 gauge or thicker
 Plywood – 1/2" or thicker
 OSB – 7/16" or thicker
 Lumber – 1x or thicker

R-PANEL

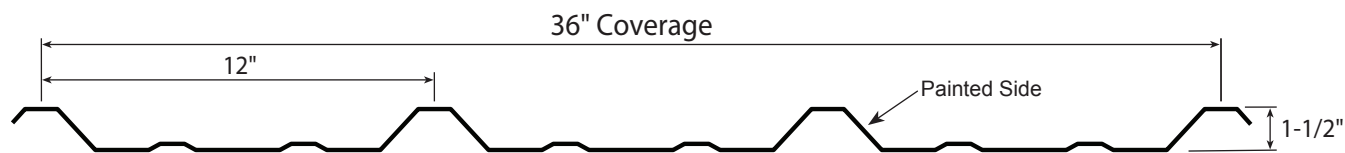

Profile	Product No.	Coverage	Gauge	Finish
	2505141	36"	26	Acrylic-Coated Galvalume® (ACG)
	25051XX	36"	26	MS Colorfast45
	26051XX	36"	26	PVDF Painted
	2705141	36"	24	Acrylic-Coated Galvalume® (ACG)
	28051XX	36"	24	PVDF Painted
	2905141	36"	22	Acrylic-Coated Galvalume® (ACG)
	29051XX	36"	22	PVDF Painted

Roof Slope

The minimum recommended slope for any R-Panel is 1:12.
Metal Sales recommends that in all roof applications sealant be used on sidelaps.

Length

Lengths under 5'-0" are available with some cutting restrictions.
Maximum recommended panel length is 45'-0".
Longer panels require additional consideration in packaging, shipping, and erection.
Please consult your Metal Sales branch for recommendations.

Fasteners

The fastener selection guide should be consulted for choosing proper fasteners for specific applications. Quantity and type of fastener must meet necessary loading and code requirements (see PGI-12-14).

Materials

Steel grade 50 per ASTM A 792 (24 and 22 gauge)
Steel grade 80 per ASTM A 792 or ASTM A 653 (26 gauge)

Finish

Acrylic Coated Galvalume® (ACG) / ASTM A792 - AZ55
Pre-painted Galvalume / ASTM A792 - AZ50
MS Colorfast45® (SMP)
PVDF (Kynar 500 or Hylar 5000®)
Differential appearance of Acrylic Coated Galvalume roofing materials is not a cause for rejection.

Support Materials

Steel Framing – 16 gauge or thicker
Plywood – 1/2" or thicker
OSB – 7/16" or thicker
Lumber – 1x or thicker

PBR-PANEL ■ REVERSE-ROLL WALL PANEL

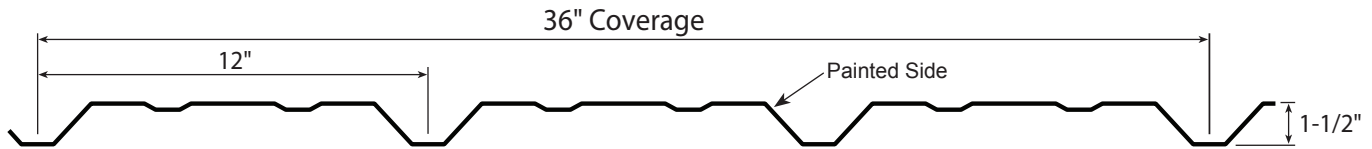

Profile	Product No.	Coverage	Gauge	Finish
	2515241	36"	26	Acrylic-Coated Galvalume® (ACG)
	25152XX	36"	26	MS Colorfast45
	26152XX	36"	26	PVDF Painted
	2815241	36"	24	Galvalume
	28152XX	36"	24	PVDF Painted

Length

Lengths under 5'-0" are available with some cutting restrictions.
 Maximum recommended panel length is 45'-0".
 Longer panels require additional consideration in packaging, shipping, and erection.
 Please consult your Metal Sales branch for recommendations.

Fasteners

The fastener selection guide should be consulted for choosing proper fasteners for specific applications. Quantity and type of fastener must meet necessary loading and code requirements (see PGI-12-14).

Materials

Steel grade 50 per ASTM A 792 (24 and 22 gauge)
 Steel grade 80 per ASTM A 792 or ASTM A 653 (26 gauge)

Finish

Acrylic Coated Galvalume® (ACG) / ASTM A792 - AZ55
 Pre-painted Galvalume / ASTM A792 - AZ50
 MS Colorfast45® (SMP)
 PVDF (Kynar 500 or Hylar 5000®)
 Differential appearance of Acrylic Coated Galvalume roofing materials is not a cause for rejection.

Support Materials

Steel Framing – 16 gauge or thicker
 Plywood – 1/2" or thicker
 OSB – 7/16" or thicker
 Lumber – 1x or thicker

R-PANEL ■ REVERSE-ROLL WALL PANEL

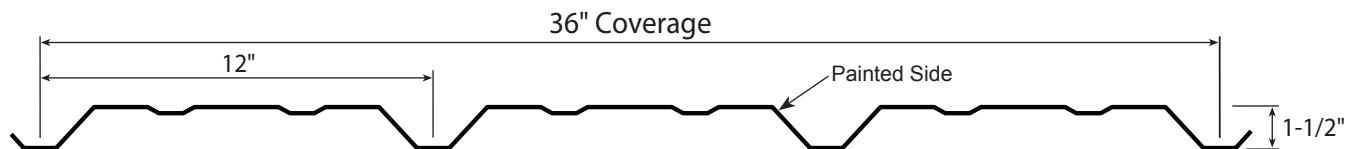

Profile	Product No.	Coverage	Gauge	Finish
	2515141	36"	26	Acrylic-Coated Galvalume® (ACG)
	25151XX	36"	26	MS Colorfast45
	26151XX	36"	26	PVDF Painted
	2815141	36"	24	Galvalume
	28151XX	36"	24	PVDF Painted

Length

Lengths under 5'-0" are available with some cutting restrictions. Maximum recommended panel length is 45'-0". Longer panels require additional consideration in packaging, shipping, and erection. Please consult your Metal Sales branch for recommendations.

Fasteners

The fastener selection guide should be consulted for choosing proper fasteners for specific applications. Quantity and type of fastener must meet necessary loading and code requirements (see PGI-12-14).

Materials

Steel grade 50 per ASTM A 792 (24 and 22 gauge)
Steel grade 80 per ASTM A 792 or ASTM A 653 (26 gauge)

Finish

Acrylic Coated Galvalume® (ACG) / ASTM A792 - AZ55
Pre-painted Galvalume / ASTM A792 - AZ50
MS Colorfast45® (SMP)
PVDF (Kynar 500 or Hylar 5000®)
Differential appearance of Acrylic Coated Galvalume roofing materials is not a cause for rejection.

Support Materials

Steel Framing – 16 gauge or thicker
Plywood – 1/2" or thicker
OSB – 7/16" or thicker
Lumber – 1x or thicker

PBR-PANEL

Flashing Profiles

20" RIDGE/HIP COVER

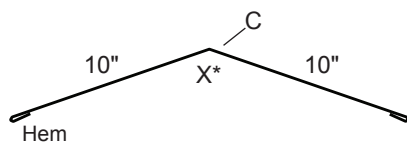

*Specify Angle

GAUGE	FINISH	PRODUCT NO.	WEIGHT	LENGTH
26	ACG	5500641	13.1 lbs	10'-2"
26	ACG	5500841	26.0 lbs	20'-3"
26	MS Colorfast45®	55006XX	13.1 lbs	10'-2"
26	MS Colorfast45®	55008XX	26.0 lbs	20'-3"
26	PVDF	56006XX	13.1 lbs	10'-2"
26	PVDF	56008XX	26.0 lbs	20'-3"
24	ACG	5700641	17.4 lbs	10'-2"
24	ACG	5700841	34.7 lbs	20'-3"
24	PVDF	58006XX	17.4 lbs	10'-2"
24	PVDF	58008XX	34.7 lbs	20'-3"

UNIVERSAL RIDGE COVER

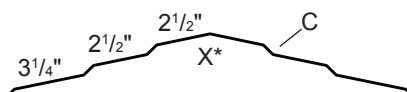

*Specify Angle

GAUGE	FINISH	PRODUCT NO.	WEIGHT	LENGTH
26	ACG	5501041	12.1 lbs	10'-2"
26	MS Colorfast45®	55010XX	12.1 lbs	10'-2"
26	PVDF	56010XX	12.1 lbs	10'-2"
24	ACG	5701041	16.2 lbs	10'-2"
24	PVDF	58010XX	16.2 lbs	10'-2"

13" STEP RIDGE

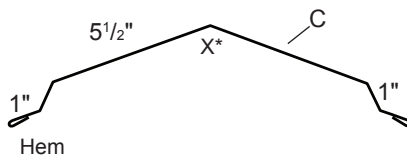

*Specify Angle

GAUGE	FINISH	PRODUCT NO.	WEIGHT	LENGTH
26	ACG	5597441	10.0 lbs	10'-2"
26	ACG	5597541	19.8 lbs	20'-3"
26	MS Colorfast45®	55974XX	10.0 lbs	10'-2"
26	MS Colorfast45®	55975XX	19.8 lbs	20'-3"
26	PVDF	56974XX	10.0 lbs	10'-2"
26	PVDF	56975XX	19.8 lbs	20'-3"
24	ACG	5797441	13.3 lbs	10'-2"
24	ACG	5797541	26.5 lbs	20'-3"
24	PVDF	58974XX	13.3 lbs	10'-2"
24	PVDF	58975XX	26.5 lbs	20'-3"

PBR-PANEL FORMED RIDGE

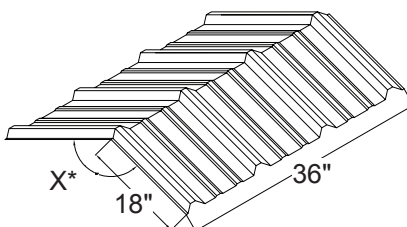

*Specify Angle

GAUGE	FINISH	PRODUCT NO.	WEIGHT	LENGTH
26	ACG	5592141	7.6 lbs	18"
26	MS Colorfast45®	55921XX	7.6 lbs	18"
26	PVDF	56921XX	7.6 lbs	18"
24	ACG	5672141	10.2 lbs	18"
24	PVDF	56722XX	10.2 lbs	18"

* See chart on page XX, Angle same as Ridge/Hip Cover.

**4:12 Maximum slope on all Formed Ridge

(Please inquire on minimum quantities required)

PBR-PANEL

Flashing Profiles

PEAK

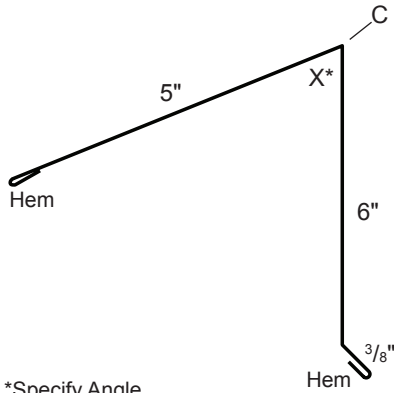

*Specify Angle

GAUGE	FINISH	PRODUCT NO.	WEIGHT	LENGTH
26	ACG	5502241	7.9 lbs	10'-2"
26	ACG	5502441	15.7 lbs	20'-3"
26	MS Colorfast45®	55022XX	7.9 lbs	10'-2"
26	MS Colorfast45®	55024XX	15.7 lbs	20'-3"
26	PVDF	56022XX	7.9 lbs	10'-2"
26	PVDF	56024XX	15.7 lbs	20'-3"
24	ACG	5702241	10.5 lbs	10'-2"
24	ACG	5702441	20.9 lbs	20'-3"
24	PVDF	58022XX	10.5 lbs	10'-2"
24	PVDF	58024XX	20.9 lbs	20'-3"

SCULPTURED HIGHSIDE EAVE

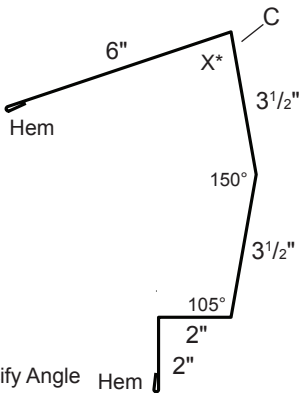

*Specify Angle

GAUGE	FINISH	PRODUCT NO.	WEIGHT	SIDE
26	ACG	5503841	11.2 lbs	10'-2"
26	ACG	5504041	22.3 lbs	20'-3"
26	MS Colorfast45®	55038XX	11.2 lbs	10'-2"
26	MS Colorfast45®	55040XX	22.3 lbs	20'-3"
26	PVDF	56038XX	11.2 lbs	10'-2"
26	PVDF	56040XX	22.3 lbs	20'-3"
24	ACG	5703841	14.9 lbs	10'-2"
24	ACG	5704041	29.8 lbs	20'-3"
24	PVDF	58038XX	14.9 lbs	10'-2"
24	PVDF	58040XX	29.8 lbs	20'-3"

EAVE

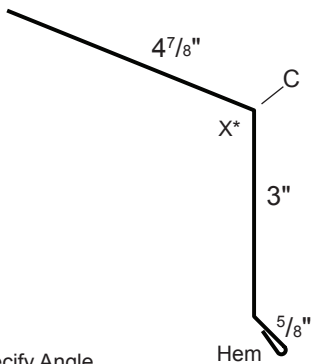

*Specify Angle

GAUGE	FINISH	PRODUCT NO.	WEIGHT	LENGTH
26	ACG	5506941	5.6 lbs	10'-2"
26	MS Colorfast45®	55069XX	5.6 lbs	10'-2"
26	PVDF	56069XX	5.6 lbs	10'-2"
24	ACG	5706941	7.5 lbs	10'-2"
24	PVDF	58069XX	7.5 lbs	10'-2"

EXTENDED EAVE

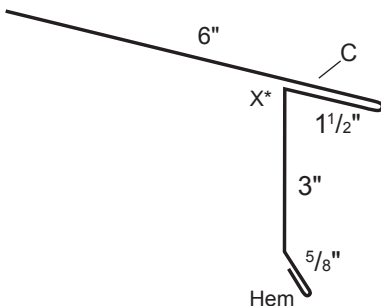

*Specify Angle

GAUGE	FINISH	PRODUCT NO.	WEIGHT	SIDE
26	ACG	5507341	8.2 lbs	10'-2"
26	MS Colorfast45®	55073XX	8.2 lbs	10'-2"
26	PVDF	56073XX	8.2 lbs	10'-2"
24	ACG	5707341	10.9 lbs	10'-2"
24	PVDF	58073XX	10.9 lbs	10'-2"

PBR-PANEL

Flashing Profiles

BOX GUTTER

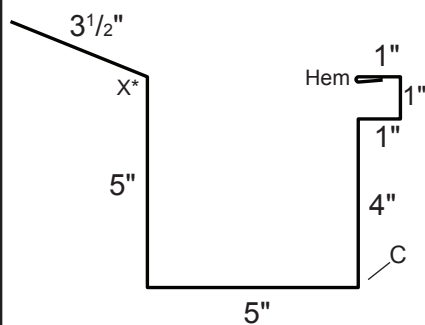

*Specify Angle

GAUGE	FINISH	PRODUCT NO.	WEIGHT	LENGTH
26	ACG	5507741	13.1 lbs	10'-2"
26	ACG	5507941	26.0 lbs	20'-3"
26	MS Colorfast45®	55077XX	13.1 lbs	10'-2"
26	MS Colorfast45®	55079XX	26.0 lbs	20'-3"
26	PVDF	56077XX	13.1 lbs	10'-2"
26	PVDF	56079XX	26.0 lbs	20'-3"
24	ACG	5707741	17.4 lbs	10'-2"
24	ACG	5707941	34.7 lbs	20'-3"
24	PVDF	58077XX	17.4 lbs	10'-2"
24	PVDF	58079XX	34.7 lbs	20'-3"

BOX GUTTER END CAP

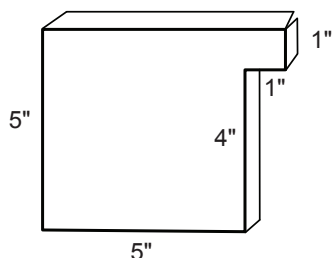

GAUGE	FINISH	PRODUCT NO.	WEIGHT	SIDE
26	ACG	5508141	0.2 lbs	Left
26	ACG	5508241	0.2 lbs	Right
26	MS Colorfast45®	55081XX	0.2 lbs	Left
26	MS Colorfast45®	55082XX	0.2 lbs	Right
26	PVDF	56081XX	0.2 lbs	Left
26	PVDF	56082XX	0.2 lbs	Right
24	ACG	5708141	0.3 lbs	Left
24	ACG	5708241	0.3 lbs	Right
24	PVDF	58081XX	0.3 lbs	Left
24	PVDF	58082XX	0.3 lbs	Right

SCULPTURED GUTTER

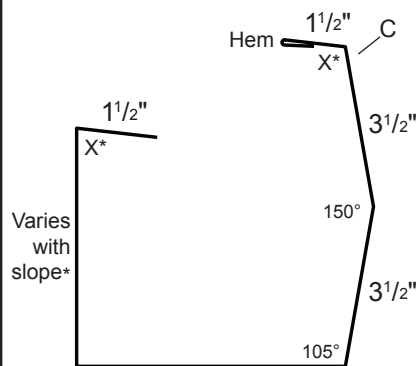

Varies with slope*

*Specify Angle

GAUGE	FINISH	PRODUCT NO.	WEIGHT	LENGTH
26	ACG	5508441	14.0 lbs	10'-2"
26	ACG	5508641	27.9 lbs	20'-3"
26	MS Colorfast45®	55084XX	14.0 lbs	10'-2"
26	MS Colorfast45®	55086XX	27.9 lbs	20'-3"
26	PVDF	56084XX	14.0 lbs	10'-2"
26	PVDF	56086XX	27.9 lbs	20'-3"
24	ACG	5708441	18.7 lbs	10'-2"
24	ACG	5708641	37.2 lbs	20'-3"
24	PVDF	58084XX	18.7 lbs	10'-2"
24	PVDF	58086XX	37.2 lbs	20'-3"

SCULPTURED END CAP

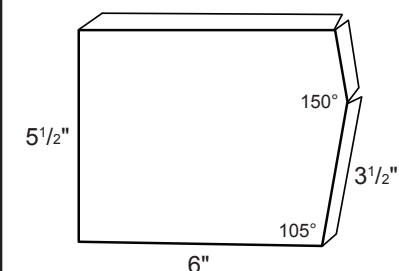

GAUGE	FINISH	PRODUCT NO.	WEIGHT	SIDE
26	ACG	5508841	0.2 lbs	Left
26	ACG	5508941	0.2 lbs	Right
26	MS Colorfast45®	55088XX	0.2 lbs	Left
26	MS Colorfast45®	55089XX	0.2 lbs	Right
26	PVDF	56088XX	0.2 lbs	Left
26	PVDF	56089XX	0.2 lbs	Right
24	ACG	5708841	0.3 lbs	Left
24	ACG	5708941	0.3 lbs	Right
24	PVDF	58088XX	0.3 lbs	Left
24	PVDF	58089XX	0.3 lbs	Right

PBR-PANEL

BOX GUTTER STRAP & DOWNSPOUT STRAP

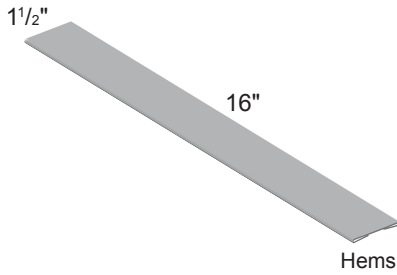

Flashing Profiles

GAUGE	FINISH	PRODUCT NO.	WEIGHT	LENGTH
26	ACG	5509241	0.2 lbs	1'-4"
26	MS Colorfast45®	55092XX	0.2 lbs	1'-4"
26	PVDF	56092XX	0.2 lbs	1'-4"
24	ACG	5709241	0.3 lbs	1'-4"
24	PVDF	58092XX	0.3 lbs	1'-4"

PBR GUTTER HANGER

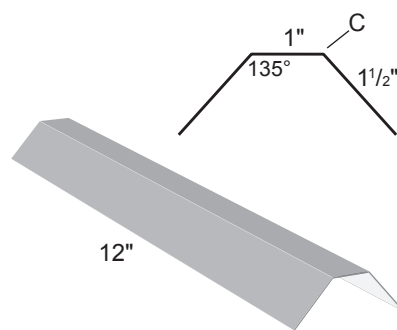

GAUGE	FINISH	PRODUCT NO.	WEIGHT	LENGTH
26	ACG	5509141	0.2 lbs	1'-0"
26	MS Colorfast45®	55091XX	0.2 lbs	1'-0"
26	PVDF	56091XX	0.2 lbs	1'-0"
24	ACG	5709141	0.3 lbs	1'-0"
24	PVDF	58091XX	0.3 lbs	1'-0"

4" x 3-1/2" DOWNSPOUT

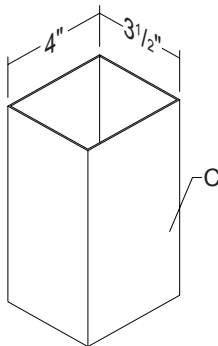

GAUGE	FINISH	PRODUCT NO.	WEIGHT	LENGTH
26	ACG	5509441	10.4 lbs	10'-2"
26	ACG	5509741	20.8 lbs	20'-3"
26	MS Colorfast45®	55094XX	10.4 lbs	10'-2"
26	MS Colorfast45®	55097XX	20.8 lbs	20'-3"
26	PVDF	56094XX	10.4 lbs	10'-2"
26	PVDF	56097XX	20.8 lbs	20'-3"
24	ACG	5709441	12.9 lbs	10'-2"
24	ACG	5709741	25.8 lbs	20'-3"
24	PVDF	58094XX	12.9 lbs	10'-2"
24	PVDF	58097XX	25.8 lbs	20'-3"

4" x 6" DOWNSPOUT

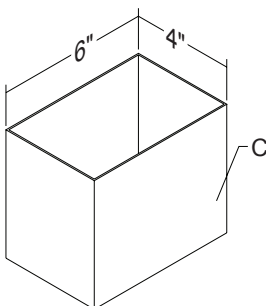

GAUGE	FINISH	PRODUCT NO.	WEIGHT	LENGTH
26	ACG	5509841	13.9 lbs	10'-2"
26	ACG	5510141	27.8 lbs	20'-3"
26	MS Colorfast45®	55098XX	13.9 lbs	10'-2"
26	MS Colorfast45®	55101XX	27.8 lbs	20'-3"
26	PVDF	56098XX	13.9 lbs	10'-2"
26	PVDF	56101XX	27.8 lbs	20'-3"
24	ACG	5709841	17.0 lbs	10'-2"
24	ACG	5710141	33.9 lbs	20'-3"
24	PVDF	58098XX	17.0 lbs	10'-2"
24	PVDF	58101XX	33.9 lbs	20'-3"

PBR-PANEL

Flashing Profiles

4" DOWNSPOUT STRAP

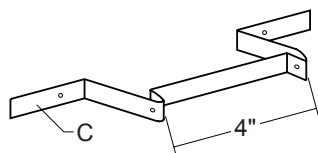

GAUGE	FINISH	PRODUCT NO.	WEIGHT
26	ACG	5511041	0.1 lbs
26	MS Colorfast45®	55110XX	0.1 lbs
26	PVDF	56110XX	0.1 lbs
24	ACG	5711041	0.1 lbs
24	PVDF	58110XX	0.1 lbs

4" x 3-1/2" ELBOW

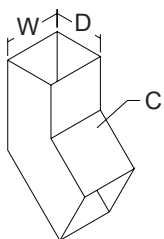
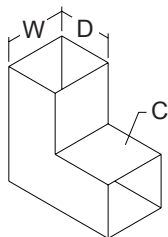

GAUGE	FINISH	PRODUCT NO.	WEIGHT	TYPE
26	ACG	5510241	2.0 lbs	95 Degree
26	MS Colorfast45®	55102XX	2.0 lbs	95 Degree
26	PVDF	56102XX	2.0 lbs	95 Degree
24	ACG	5710241	2.3 lbs	95 Degree
24	PVDF	58102XX	2.3 lbs	95 Degree
26	ACG	5510641	2.0 lbs	45 Degree
26	MS Colorfast45®	55106XX	2.0 lbs	45 Degree
26	PVDF	56106XX	2.0 lbs	45 Degree
24	ACG	5710641	2.3 lbs	45 Degree
24	PVDF	58106XX	2.3 lbs	45 Degree

6" DOWNSPOUT STRAP

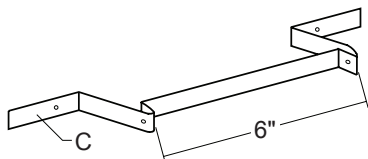

GAUGE	FINISH	PRODUCT NO.	WEIGHT
26	ACG	5511241	0.1 lbs
26	MS Colorfast45®	55112XX	0.1 lbs
26	PVDF	56112XX	0.1 lbs
24	ACG	5711241	0.2 lbs
24	PVDF	58112XX	0.2 lbs

6" x 4" ELBOW

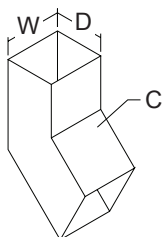
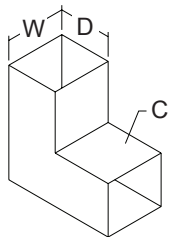

GAUGE	FINISH	PRODUCT NO.	WEIGHT	TYPE
26	ACG	5510441	2.0 lbs	95 Degree
26	MS Colorfast45®	55104XX	2.0 lbs	95 Degree
26	PVDF	56104XX	2.0 lbs	95 Degree
24	ACG	5710441	3.0 lbs	95 Degree
24	PVDF	58104XX	3.0 lbs	95 Degree
26	ACG	5510841	2.0 lbs	45 Degree
26	MS Colorfast45®	55108XX	2.0 lbs	45 Degree
26	PVDF	56108XX	2.0 lbs	45 Degree
24	ACG	5710841	3.0 lbs	45 Degree
24	PVDF	58108XX	3.0 lbs	45 Degree

PBR-PANEL

Flashing Profiles

2" VALLEY 10"

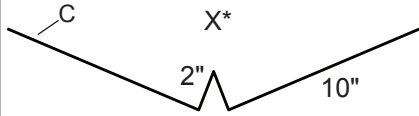

*Specify Angle

GAUGE	FINISH	PRODUCT NO.	WEIGHT	LENGTH
26	ACG	5301841	14.9 lbs	10'-2"
26	MS Colorfast45®	53018XX	14.9 lbs	10'-2"
26	MS Colorfast45®	55020XX	29.8 lbs	20'-3"
26	PVDF	54018XX	14.9 lbs	10'-2"
26	PVDF	56020XX	29.8 lbs	20'-3"
24	ACG	5701841	19.9 lbs	10'-2"
24	ACG	5702041	39.7 lbs	20'-3"
24	PVDF	58018XX	19.9 lbs	10'-2"
24	PVDF	58020XX	39.7 lbs	20'-3"

1.5" VALLEY 9"

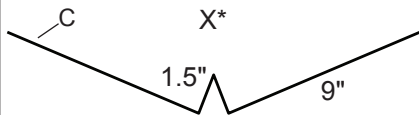

*Specify Angle

GAUGE	FINISH	PRODUCT NO.	WEIGHT	LENGTH
26	ACG	5517141	13.7 lbs	10'-2"
26	MS Colorfast45®	55171XX	13.7 lbs	10'-2"
24	ACG	5817141	18.3 lbs	10'-2"
24	PVDF	58171XX	18.3 lbs	10'-2"

PERFORATED VENT DRIP

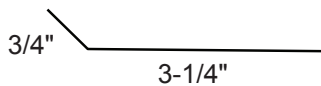

23% Open Area in Perforation - See Detail on Page 56

THICKNESS	MATERIAL	PRODUCT NO.	WEIGHT	LENGTH
0.032	Aluminum	6013981	2.8 lbs	10'-2"

PBR-PANEL

Flashing Profiles

PBR STEP RAKE

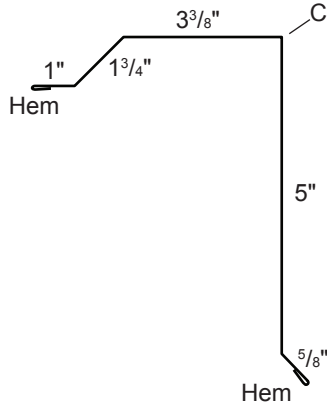

GAUGE	FINISH	PRODUCT NO.	WEIGHT	LENGTH
26	ACG	5590441	7.9 lbs	10'-2"
26	MS Colorfast45®	55904XX	7.9 lbs	10'-2"
26	PVDF	56904XX	7.9 lbs	10'-2"
24	ACG	5790441	10.6 lbs	10'-2"
24	PVDF	59904XX	10.6 lbs	10'-2"

BOX RAKE

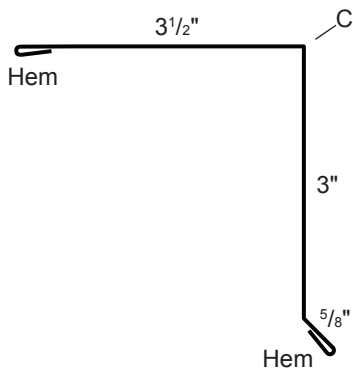

GAUGE	FINISH	PRODUCT NO.	WEIGHT	LENGTH
26	ACG	5012641	5.1 lbs	10'-2"
26	MS Colorfast45®	50126XX	5.1 lbs	10'-2"

PBR SCULPTURED RAKE

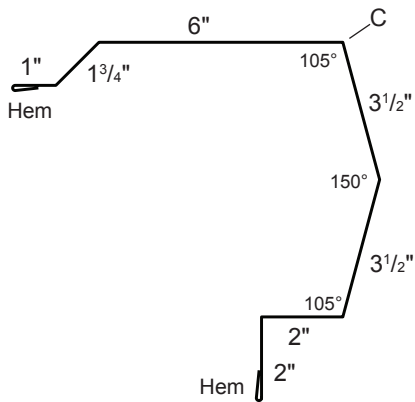

GAUGE	FINISH	PRODUCT NO.	WEIGHT	LENGTH
26	ACG	5591141	12.9 lbs	10'-2"
26	ACG	5591241	25.7 lbs	20'-3"
26	MS Colorfast45®	55911XX	12.9 lbs	10'-2"
26	MS Colorfast45®	55912XX	25.7 lbs	20'-3"
26	PVDF	56911XX	12.9 lbs	10'-2"
26	PVDF	56912XX	25.7 lbs	20'-3"
24	ACG	5791141	17.2 lbs	10'-2"
24	ACG	5791241	34.3 lbs	20'-3"
24	PVDF	58911XX	17.2 lbs	10'-2"
24	PVDF	58912XX	34.3 lbs	20'-3"

SCULPTURED RAKE END

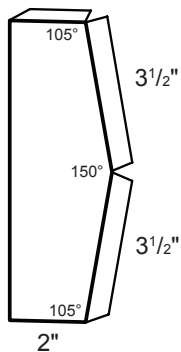

GAUGE	FINISH	PRODUCT NO.	WEIGHT	LENGTH
26	ACG	5504641	0.1 lbs	Works for both left and right applications
26	MS Colorfast45®	55046XX	0.1 lbs	
26	PVDF	56046XX	0.1 lbs	
24	ACG	5704641	0.2 lbs	
24	PVDF	58046XX	0.2 lbs	

PBR-PANEL

Flashing Profiles

PBR RAKEWALL

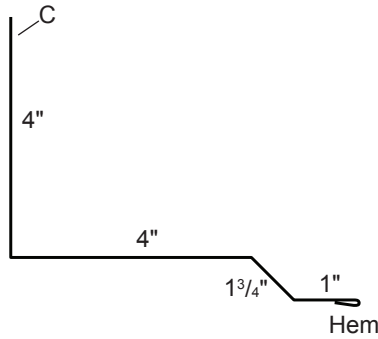

GAUGE	FINISH	PRODUCT NO.	WEIGHT	LENGTH
26	ACG	5590241	7.0 lbs	10'-2"
26	ACG	5590341	14.0 lbs	20'-3"
26	MS Colorfast45®	55902XX	7.0 lbs	10'-2"
26	MS Colorfast45®	55903XX	14.0 lbs	20'-3"
26	PVDF	56902XX	7.0 lbs	10'-2"
24	ACG	5790241	9.3 lbs	10'-2"
24	ACG	5790341	18.6 lbs	20'-3"
24	PVDF	58902XX	9.3 lbs	10'-2"
24	PVDF	58903XX	18.6 lbs	20'-3"

PITCH BREAK

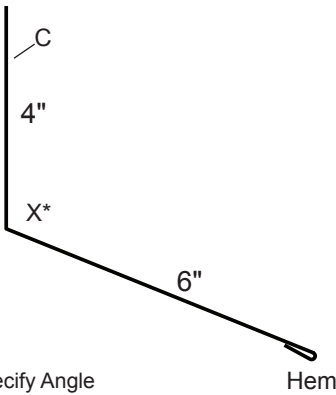

GAUGE	FINISH	PRODUCT NO.	WEIGHT	LENGTH
26	ACG	5504841	6.5 lbs	10'-2"
26	MS Colorfast45®	55048XX	6.5 lbs	10'-2"
26	PVDF	56048XX	6.5 lbs	10'-2"
24	ACG	5704841	8.7 lbs	10'-2"
24	PVDF	58048XX	8.7 lbs	10'-2"

COUNTER FLASHING

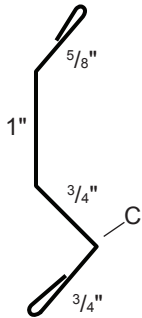

GAUGE	FINISH	PRODUCT NO.	WEIGHT	LENGTH
26	ACG	5505241	2.6 lbs	10'-2"
26	MS Colorfast45®	55052XX	2.6 lbs	10'-2"
26	PVDF	56052XX	2.6 lbs	10'-2"
24	ACG	5705241	3.4 lbs	10'-2"
24	PVDF	58052XX	3.4 lbs	10'-2"

REGLET FLASHING

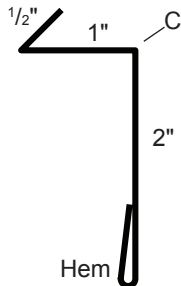

GAUGE	FINISH	PRODUCT NO.	WEIGHT	LENGTH
26	ACG	5505441	2.5 lbs	10'-2"
26	MS Colorfast45®	55054XX	2.5 lbs	10'-2"
26	PVDF	56054XX	2.5 lbs	10'-2"
24	ACG	5705441	3.3 lbs	10'-2"
24	PVDF	58054XX	3.3 lbs	10'-2"

PBR-PANEL

Flashing Profiles

PBR OUTSIDE CORNER

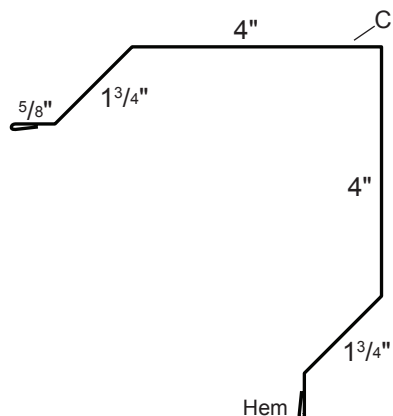

GAUGE	FINISH	PRODUCT NO.	WEIGHT	LENGTH
26	ACG	5591441	8.6 lbs	10'-2"
26	ACG	5591541	11.9 lbs	14'-2"
26	ACG	5591641	17.1 lbs	20'-3"
26	MS Colorfast45®	55914XX	8.6 lbs	10'-2"
26	MS Colorfast45®	55915XX	11.9 lbs	14'-2"
26	MS Colorfast45®	55916XX	17.1 lbs	20'-3"
26	PVDF	56914XX	8.6 lbs	10'-2"
26	PVDF	56915XX	11.9 lbs	14'-2"
26	PVDF	56916XX	17.1 lbs	20'-3"
24	ACG	5891441	11.4 lbs	10'-2"
24	ACG	5891541	15.9 lbs	14'-2"
24	ACG	5891641	22.7 lbs	20'-3"
24	PVDF	58914XX	11.4 lbs	10'-2"
24	PVDF	58915XX	15.9 lbs	14'-2"
24	PVDF	58916XX	22.7 lbs	20'-3"

OUTSIDE CORNER

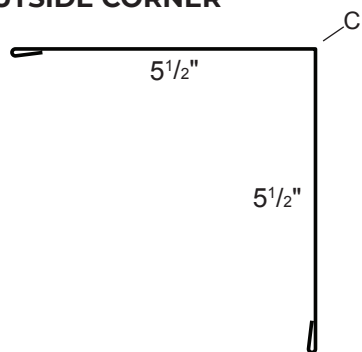

GAUGE	FINISH	PRODUCT NO.	WEIGHT	LENGTH
26	ACG	5513241	7.5 lbs	10'-2"
26	ACG	5513641	14.9 lbs	20'-3"
26	MS Colorfast45®	55132XX	7.5 lbs	10'-2"
26	MS Colorfast45®	55136XX	14.9 lbs	20'-3"
26	PVDF	56132XX	7.5 lbs	10'-2"
26	PVDF	56136XX	14.9 lbs	20'-3"
24	ACG	5713241	10.0 lbs	10'-2"
24	ACG	5713641	19.8 lbs	20'-3"
24	PVDF	58132XX	10.0 lbs	10'-2"
24	PVDF	58136XX	19.8 lbs	20'-3"

PBR INSIDE CORNER

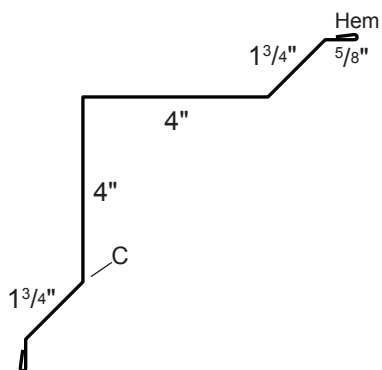

GAUGE	FINISH	PRODUCT NO.	WEIGHT	LENGTH
26	ACG	5591741	8.6 lbs	10'-2"
26	ACG	5591841	11.9 lbs	14'-2"
26	ACG	5591941	17.1 lbs	20'-3"
26	MS Colorfast45®	55917XX	8.6 lbs	10'-2"
26	MS Colorfast45®	55918XX	11.9 lbs	14'-2"
26	MS Colorfast45®	55919XX	17.1 lbs	20'-3"
26	PVDF	56917XX	8.6 lbs	10'-2"
26	PVDF	56918XX	11.9 lbs	14'-2"
26	PVDF	56919XX	17.1 lbs	20'-3"
24	ACG	5791641	11.4 lbs	10'-2"
24	PVDF	58937XX	11.4 lbs	10'-2"

INSIDE CORNER

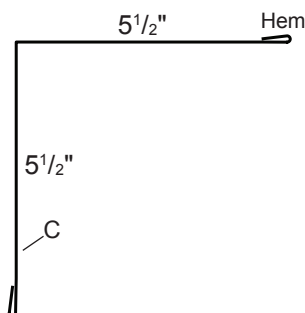

GAUGE	FINISH	PRODUCT NO.	WEIGHT	LENGTH
26	ACG	5512641	7.5 lbs	10'-2"
26	ACG	5513041	14.9 lbs	20'-3"
26	MS Colorfast45®	55126XX	7.5 lbs	10'-2"
26	MS Colorfast45®	55130XX	14.9 lbs	20'-3"
26	PVDF	56126XX	7.5 lbs	10'-2"
26	PVDF	56130XX	14.9 lbs	20'-3"
24	ACG	5712641	10.0 lbs	10'-2"
24	ACG	5713041	19.8 lbs	20'-3"
24	PVDF	58126XX	10.0 lbs	10'-2"
24	PVDF	58130XX	19.8 lbs	20'-3"

PBR-PANEL

Flashing Profiles

SCULPTURED PEAK BOX

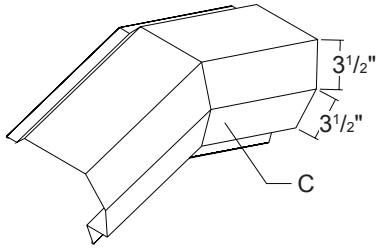

GAUGE	FINISH	PRODUCT NO.	WEIGHT
26	ACG	5596341	3.8 lbs
26	MS Colorfast45®	55963XX	3.8 lbs
26	PVDF	56963XX	3.8 lbs
24	ACG	5796341	5.1 lbs
24	PVDF	58963XX	5.1 lbs

SCULPTURED CORNER BOX

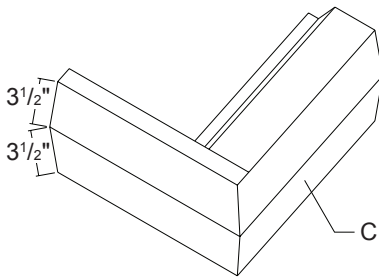

Looking from Eave to Ridge
(Right Shown)

GAUGE	FINISH	PRODUCT NO.	WEIGHT	SIDE
26	ACG	5596441	3.8 lbs	Left
26	ACG	5596241	3.8 lbs	Right
26	MS Colorfast45®	55964XX	3.8 lbs	Left
26	MS Colorfast45®	55962XX	3.8 lbs	Right
24	ACG	5796441	5.1 lbs	Left
24	ACG	5796241	5.1 lbs	Right
24	PVDF	58964XX	5.1 lbs	Left
24	PVDF	58962XX	5.1 lbs	Right

HEAD/JAMB COVER

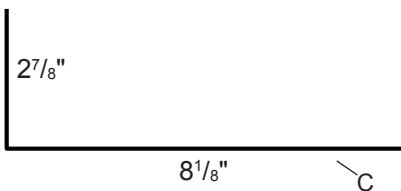

GAUGE	FINISH	PRODUCT NO.	WEIGHT	LENGTH
26	ACG	5512441	8.6 lbs	10'-2"
26	ACG	5596141	12.0 lbs	14'-2"
26	MS Colorfast45®	55124XX	8.6 lbs	10'-2"
26	MS Colorfast45®	55961XX	12.0 lbs	14'-2"
26	PVDF	56124XX	8.6 lbs	10'-2"
26	PVDF	56961XX	12.0 lbs	14'-2"
24	ACG	5712441	11.5 lbs	10'-2"
24	PVDF	58124XX	11.5 lbs	10'-2"

COPING

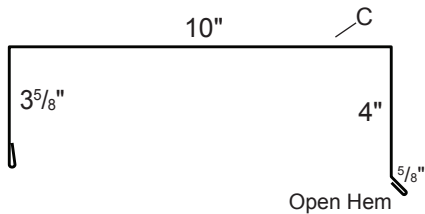

GAUGE	FINISH	PRODUCT NO.	WEIGHT	LENGTH
26	ACG	5502641	12.0 lbs	10'-2"
26	MS Colorfast45®	55026__	12.0 lbs	10'-2"
24	ACG	5702641	16.0 lbs	10'-2"
24	PVDF	58026__	16.0 lbs	10'-2"

PBR-PANEL

Flashing Profiles

1.25" BASE

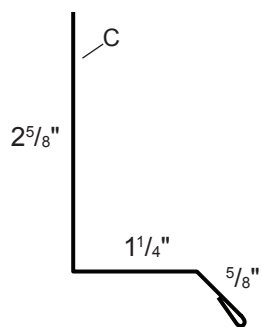

GAUGE	FINISH	PRODUCT NO.	WEIGHT	LENGTH
26	ACG	5513841	3.1 lbs	10'-2"
26	MS Colorfast45®	55138XX	3.1 lbs	10'-2"
26	PVDF	56138XX	3.1 lbs	10'-2"
24	ACG	5713841	4.2 lbs	10'-2"
24	PVDF	58138XX	4.2 lbs	10'-2"

1.5" SILL/HEAD

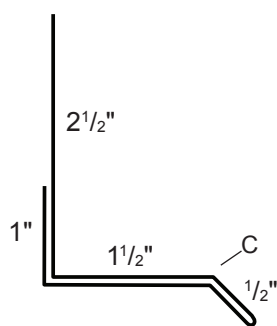

GAUGE	FINISH	PRODUCT NO.	WEIGHT	LENGTH
26	ACG	5511441	4.7 lbs	10'-2"
26	MS Colorfast45®	55114XX	4.7 lbs	10'-2"
26	PVDF	56114XX	4.7 lbs	10'-2"
24	ACG	5711441	6.2 lbs	10'-2"
24	PVDF	58114XX	6.2 lbs	10'-2"

1.5" SILL TO SOFFIT

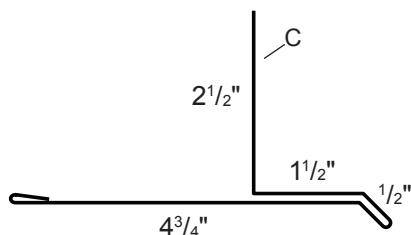

GAUGE	FINISH	PRODUCT NO.	WEIGHT	LENGTH
26	ACG	5511841	6.2 lbs	10'-2"
26	MS Colorfast45®	55118XX	6.2 lbs	10'-2"
26	PVDF	56118XX	6.2 lbs	10'-2"
24	ACG	5711841	8.3 lbs	10'-2"
24	PVDF	58118XX	8.3 lbs	10'-2"

HEAD CHANNEL

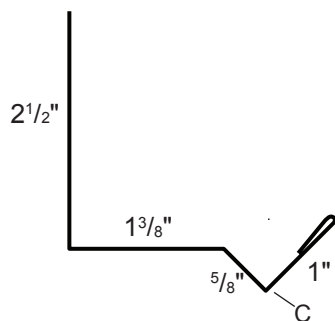

GAUGE	FINISH	PRODUCT NO.	WEIGHT	LENGTH
26	ACG	5596041	1.3 lbs	3'-6"
26	ACG	5512241	3.7 lbs	10'-2"
26	MS Colorfast45®	55960XX	1.3 lbs	3'-6"
26	MS Colorfast45®	55122XX	3.7 lbs	10'-2"
26	PVDF	56960XX	1.3 lbs	3'-6"
26	PVDF	56122XX	3.7 lbs	10'-2"
24	ACG	5712241	5.0 lbs	10'-2"
24	PVDF	58122XX	5.0 lbs	10'-2"

PBR-PANEL

Flashing Profiles

PBR JAMB

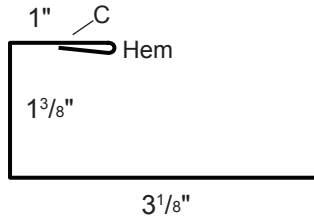

GAUGE	FINISH	PRODUCT NO.	WEIGHT	LENGTH
26	ACG	5596641	2.7 lbs	7'-3"
26	ACG	5520841	3.7 lbs	10'-2"
26	ACG	5596741	5.2 lbs	14'-2"
26	MS Colorfast45®	55966XX	2.7 lbs	7'-3"
26	MS Colorfast45®	55208XX	3.7 lbs	10'-2"
26	MS Colorfast45®	55967XX	5.2 lbs	14'-2"
26	PVDF	56966XX	2.7 lbs	7'-3"
26	PVDF	56208XX	3.7 lbs	10'-2"
26	PVDF	56967XX	5.2 lbs	14'-2"
24	ACG	5796641	3.6 lbs	7'-3"
24	ACG	5720841	5.0 lbs	10'-2"
24	ACG	5796741	6.9 lbs	14'-2"
24	PVDF	58966XX	3.6 lbs	7'-3"
24	PVDF	58208XX	5.0 lbs	10'-2"
24	PVDF	58967XX	6.9 lbs	14'-2"

PBR C-CLOSURE

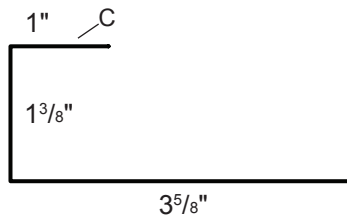





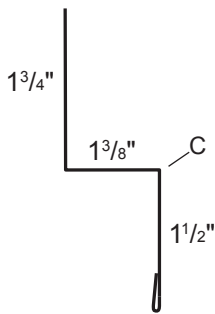

GAUGE	FINISH	PRODUCT NO.	WEIGHT	LENGTH
26	ACG	5520641	3.7 lbs	10'-2"
26	MS Colorfast45®	55206XX	3.7 lbs	10'-2"
26	PVDF	56206XX	3.7 lbs	10'-2"
24	ACG	5720641	5.0 lbs	10'-2"
24	PVDF	58206XX	5.0 lbs	10'-2"

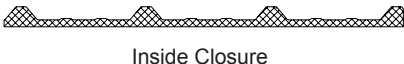
DOUBLE ANGLE

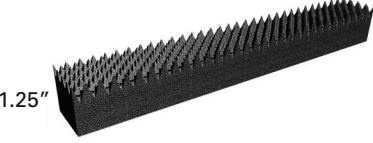

GAUGE	FINISH	PRODUCT NO.	WEIGHT	LENGTH
26	ACG	5520641	4.3 lbs	10'-2"
26	MS Colorfast45®	55206XX	4.3 lbs	10'-2"
26	PVDF	56206XX	4.3 lbs	10'-2"
24	ACG	5720641	5.8 lbs	10'-2"
24	PVDF	58206XX	5.8 lbs	10'-2"

PBR-PANEL	Accessories				
CLOSURES	GAUGE	FINISH	PRODUCT NO.	WEIGHT	LENGTH
 Outside Closure	1" x 3'-0"	Polyethylene Foam Glued	6460699	9.0 lbs	
 Inside Closure	1" x 3'-0"	Polyethylene Foam Glued	6460800	7.0 lbs	
UNIVERSAL CLOSURE	SIZE	TYPE	PRODUCT NO.	WT/100	COLOR
	1" x 1 1/2" x 25'	Polyethylene Foam	6411499	2.0 lbs	Grey
	1" x 1 1/2" x 50'	Polyethylene Foam	6411299	4.0 lbs	Grey
LP2 RIDGE VENT	SIZE	TYPE	PRODUCT NO.	WT/10	CTN QTY
	1" x 1 1/2" x 10'	Vented Foam	6460899	0.9 lbs	10
VERSA VENT	SIZE	TYPE	PRODUCT NO.	WT/10	CTN QTY
 1.25"	1" x 1 1/2" x 10'	Vented Foam	6462750	0.8 lbs	10
PROFILE VENT	SIZE	TYPE	PRODUCT NO.	WEIGHT	CTN QTY
	2 Rolls at 25'	Vented Foam	6442300	7.0 lbs	2

PBR-PANEL	Accessories				
	SIZE	TYPE	PRODUCT NO.	WT/24	
	$\frac{3}{8}$ " x $\frac{3}{32}$ " x 50'	Butyl	6404099	48.0 lbs	24 Rolls
	SIZE	TYPE	PRODUCT NO.	WT/CTN	CTN QTY
	$\frac{7}{8}$ " x $\frac{3}{16}$ " x 25'	Butyl	6403899	57.6 lbs	24 Rolls
	$\frac{7}{8}$ " x $\frac{3}{16}$ " x 40'	Butyl	6403999	48.0 lbs	10 Rolls
	SIZE	TYPE	PRODUCT NO.	WT/CTN	CTN QTY
	10.3 oz	Urethane White	6402830	29.1 lbs	30 Tubes
	10.3 oz	Urethane Bronze	6402999	29.1 lbs	30 Tubes
	10.3 oz	Urethane Grey	6402829	29.1 lbs	30 Tubes
	SIZE	TYPE	PRODUCT NO.	WT/CTN	CTN QTY

PBR-PANEL

Accessories

LIGHT TRANSMITTING PANEL



SIZE	S.F. WEIGHT	PRODUCT NO.	WT/PC	COLOR
3'-0" X 12'-0"	8 oz	6190030	21.0 lbs	White

RUBBER ROOF DECK FLASHING



SIZE	TYPE	PRODUCT NO.	BASE DIA.	WEIGHT
#1 Flasher	Rubber	68501XX*	1/4" - 2"	3.0 lbs
#2 Flasher	Rubber	68502XX*	1 3/4" - 3 1/4"	3.5 lbs
#3 Flasher	Rubber	68503XX*	1/4" - 5"	4.0 lbs
#4 Flasher	Rubber	68504XX*	3" - 6 1/4"	4.5 lbs
#5 Flasher	Rubber	68505XX*	4 1/4" - 7 1/2"	5.0 lbs
#6 Flasher	Rubber	68506XX*	5" - 9"	6.0 lbs
#7 Flasher	Rubber	68507XX*	6" - 11"	11.0 lbs
#8 Flasher	Rubber	68508XX*	7" - 13"	12.0 lbs
#9 Flasher	Rubber	68509XX*	10" - 19"	13.0 lbs
*Special order colors: 93=Brown; 94=Green; 95=Red; 96=Blue; 97=White; 98=Grey; 99=Black				
#1 Flasher	HT Silicone	6850011	1/4" - 2"	3.0 lbs
#2 Flasher	HT Silicone	6850012	1 3/4" - 3 1/4"	3.5 lbs
#3 Flasher	HT Silicone	6850013	1/4" - 5"	4.0 lbs
#4 Flasher	HT Silicone	6850014	3" - 6 1/4"	4.5 lbs
#5 Flasher	HT Silicone	6850015	4 1/4" - 7 1/2"	5.0 lbs
#6 Flasher	HT Silicone	6850016	5" - 9"	6.0 lbs
#7 Flasher	HT Silicone	6850017	6" - 11"	11.0 lbs
#8 Flasher	HT Silicone	6850018	7" - 13"	12.0 lbs
#9 Flasher	HT Silicone	6850019	10" - 19"	13.0 lbs
#1 Masterflash	Retrofit HT	6850060	1/4" - 2"	4.0 lbs
#2 Masterflash	Retrofit HT	6850061	1 1/4" - 3"	4.4 lbs
#3 Masterflash	Retrofit HT	6850062	1/4" - 4"	4.7 lbs

GRAY ROUND RETRO ROOF JACK

#1 Masterflash	Retrofit E.P.D.M	6850073	1/4" - 2"	4.0 lbs
#2 Masterflash	Retrofit E.P.D.M	6850074	1 1/4" - 3"	4.4 lbs
#3 Masterflash	Retrofit E.P.D.M	6850075	1/4" - 4"	4.7 lbs

BLACK ROUND RETRO ROOF JACK

#1 Masterflash	Retrofit E.P.D.M	6850070	1/4" - 2"	4.0 lbs
#2 Masterflash	Retrofit E.P.D.M	6850071	1 1/4" - 3"	4.4 lbs
#3 Masterflash	Retrofit E.P.D.M	6850072	1/4" - 4"	4.7 lbs

BLACK SQUARE RETRO ROOF JACK

#1 Masterflash	Retrofit E.P.D.M	6850046	1/4" - 2"	4.0 lbs
#2 Masterflash	Retrofit E.P.D.M	6850047	1 1/4" - 3"	4.4 lbs
#3 Masterflash	Retrofit E.P.D.M	6850048	1/4" - 4"	4.7 lbs

PBR-PANEL

Accessories

PBR-PANEL SHEAR



PROFILES	TYPE	PRODUCT NO.	WEIGHT	BLADE
PBR-Panel and R-Panel	Straight	6536799	100.3 lbs	42"

ms-HT UNDERLAYMENT



SIZE	TYPE	PRODUCT NO.	WT/ROLL	COVERAGE
36" x 75'-0"	Peel-n-Stick High Temp Underlayment	4121200	44.0 lbs	2 Squares/Roll

UNDERLAYMENT PRIMER

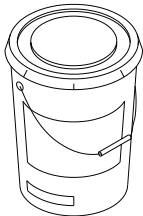

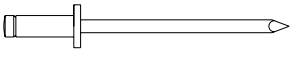
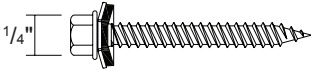
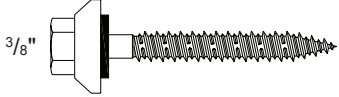
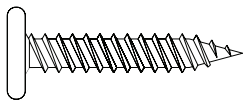
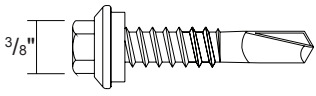
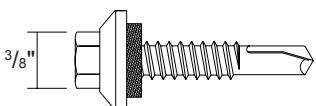
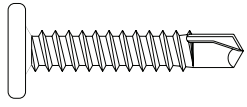
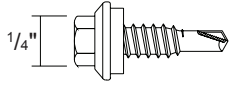
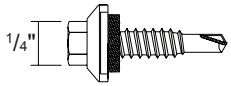

SIZE	TYPE	PRODUCT NO.	COVERAGE
5 Gallon	Liquid	6600000	100-125 sf per gallon depending on substrate

SIZE	CONTENTS	PRODUCT NO.	WT/ROLL	COVERAGE

PBR-PANEL		Fasteners				
POP RIVET  *Limited stocked colors		SIZE	TYPE	PRODUCT NO.	FINISH	WT/250
		1/8" x 3/16"	Aluminum	8240901	Unpainted	0.75 lbs
		1/8" x 3/16"	Aluminum	82409XX	Painted*	0.75 lbs
		1/8" x 3/8"	Aluminum	82402XX	Painted*	0.75 lbs
WOODSCREW 		SIZE	TYPE	PRODUCT NO.	FINISH	WT/250
		#10-14 x 1"	A	82101XX	Painted	4.3 lbs
		#10-14 x 1 1/2"	A	82103XX	Painted	5.5 lbs
		#10-14 x 2"	A	82104XX	Painted	6.7 lbs
WOODSCREW XL 		SIZE	TYPE	PRODUCT NO.	FINISH	WT/250
		#10-14 x 1"	A	8212100	XL	6.5 lbs
		#10-14 x 1 1/2"	A	8212300	XL	7.5 lbs
		XL Fasteners are recommended for use with bare galvalume panels and flashings.				
PANCAKE HEAD WOODSCREW 		SIZE	TYPE	PRODUCT NO.	FINISH	WT/250
		#10-12 x 1"	A	8243100	Plated	6.5 lbs
SELF DRILLER (SD) 		SIZE	TYPE	PRODUCT NO.	FINISH	WT/250
		#12-14 x 1"	Driller	82201XX	Painted	7.8 lbs
		#12-14 x 1 1/4"	Driller	82202XX	Painted	8.1 lbs
		#12-14 x 1 1/2"	Driller	82203XX	Painted	8.5 lbs
		#12-14 x 2"	Driller	82204XX	Painted	11.0 lbs
SELF DRILLER XL 		SIZE	TYPE	PRODUCT NO.	FINISH	WT/250
		#12-14 x 1"	Driller	8235300	XL	12.0 lbs
		#12-14 x 1 1/2"	Driller	8235400	XL	13.0 lbs
		#12-14 x 2"	Driller	8235500	XL	14.0 lbs
		XL Fasteners are recommended for use with bare galvalume panels and flashings.				
PANCAKE HEAD SELF DRILLER 		SIZE	TYPE	PRODUCT NO.	FINISH	WT/250
		#10-16 x 1"	Driller	8242100	XL	6.5 lbs
STITCH 		SIZE	TYPE	PRODUCT NO.	FINISH	WT/250
		1/4" -14 x 7/8"	Stitch	82348XX	Painted	7.7 lbs
STITCH XL 		SIZE	TYPE	PRODUCT NO.	FINISH	WT/250
		1/4" -14 x 7/8"	Stitch	8236800	XL	10.5 lbs
		1/4" -14 x 7/8"	Stitch	82368XX	Painted	10.5 lbs
XL Fasteners are recommended for use with bare galvalume panels and flashings.						

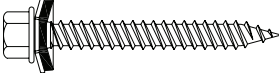

PBR-PANEL

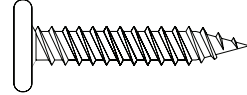
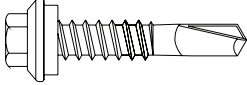
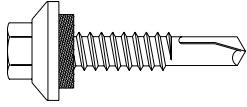
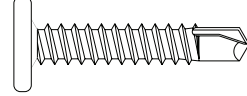
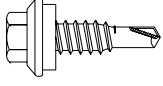
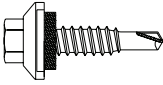
Fastener Physical Properties

FASTENER	SIZE	HEAD DIA/TYPE	THREAD DIA. O.D.	THREAD DIA. I.D.	MIN TENSILE	MIN. TORSIONAL	NOM. SHEAR
WOODSCREW 	#10-14	1/4" HWH	.190-.200	.128-.133			
WOODSCREW XL 	#10-14	1/4" HWH	.190-.200	.128-.133			
PANCAKE HEAD WOODSCREW 							
SELF DRILLER 	#12-14	5/16" HWH	.209-.215	.157-.165	3446	128	2100
SELF DRILLER XL 	#12-14	5/16" HWH	.209-.215	.157-.165	3446	130	2100
PANCAKE HEAD SELF DRILLER 							
STITCH 	1/4 -14	5/16" HWH	.240-.246	.185-.192			
STITCH XL 	1/4 -14	5/16" HWH	.240-.246	.185-.192			

PBR-PANEL

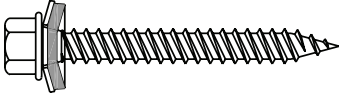
Fastener Pull Out Values

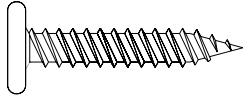
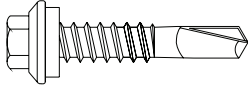
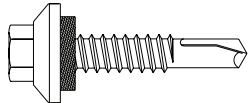
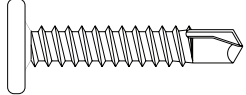
FASTENER	Size	Plywood		OSB	2X Southern Yellow Pine	
		5/8"	1/2"	7/16"		
<p>WOODSCREW</p> 	#10-14	428	328	183	555	
<p>WOODSCREW XL</p> 	#10-14	428	328	183	555	
<p>PANCAKE HEAD WOODSCREW</p> 	#10-12					
FASTENER	Size	STEEL				
		12 Ga. (55)	14 Ga. (55)	16 Ga. (55)	18 Ga. (50)	22 Ga. (50)
<p>SELF DRILLER</p> 	#12-14	1788	1056	850	790	180
<p>SELF DRILLER XL</p> 	#12-14	1788	1056	850	790	180
<p>PANCAKE HEAD SELF DRILLER</p> 	#10-14					

PBR-PANEL

Fastener Pull Out Values

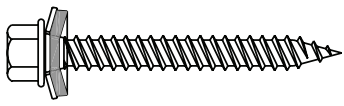
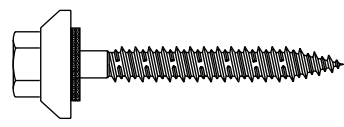
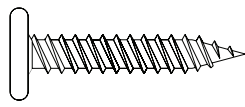
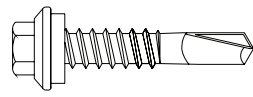
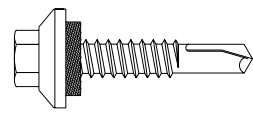
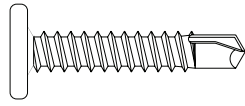
FASTENER	SIZE	STEEL					
		20 Ga.	22 Ga. (50)	24 Ga. (50)	26 Ga. (80)	26 Ga. (50)	29 Ga. (80)
WOODSCREW 	#10-14						
WOODSCREW XL 	#10-14						
PANCAKE HEAD WOODSCREW 							
SELF DRILLER 	#12-14		1357	918	751	667	524
SELF DRILLER XL 	#12-14						
PANCAKE HEAD SELF DRILLER 							

PANEL PROFILE

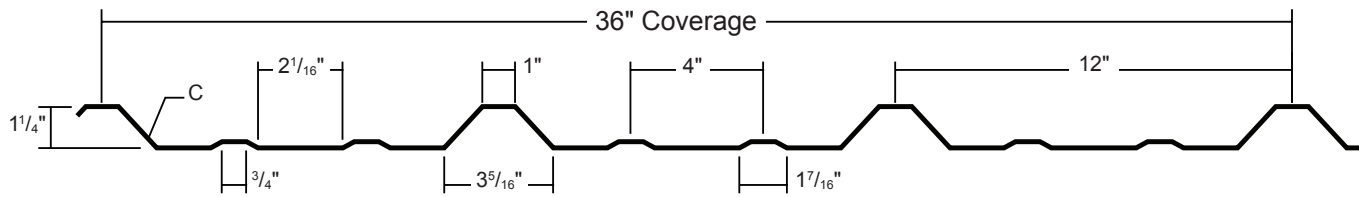

PANEL OVERVIEW

- Finishes: PVDF, MS Colorfast45° and Acrylic-Coated Galvalume®
- Corrosion Protection: AZ55 per ASTM A 792 for unpainted Galvalume®
AZ50 per ASTM A 792 for painted Galvalume®
G90 per ASTM A 653 for Galvanized
- Gauges: 26 ga and 24 ga standard; 22 ga optional
- 36" panel coverage, 1-1/4" rib height
- Panel Length: Minimum: 5'-0"; Maximum: 45'-0" recommended
- Exposed fastened metal building roof and wall system
- Trapezoidal rib on 12" centers
- Minimum roof slope: 1:12

TESTING AND APPROVALS

- UL 2218 Impact Resistance - Class 4
- UL 790 Fire Resistance Rating - Class A, per building code
- UL 263 Fire Resistance Rating - per assembly
- ASTM E 1592 Structural Performance
- UL 580 Uplift Resistance - Class 90 Construction: #161
- Texas Windstorm - Evaluations RC-198, RC-265 and RC-279
- 2023 FBC Approvals - FL9482.4, FL10999.7 and FL14645.11
- Miami-Dade County, Florida NOA 20-0331.02 - Wall expires 4/22/2025
- Miami-Dade County, Florida NOA 20-0331.03 - Roof expires 4/22/2025
- ICC Evaluation Report - ESR-2385

FASTENING INFORMATION

- Overdriven fasteners will cause panel distortions.
- Fasteners should extend 1/2" or more past the inside face of the support material.
- Thick panels (ex. 18 ga) or supports (ex. 1/2" steel) may require predrilling of holes for screws.
- Panel Fastener:
 - Attaching to Wood:
 - #10-14 XL Wood Screw
 - Attaching to Steel:
 - #12-14 XL Self Drilling Screw
- Trim Fastener:
 - 1/4"-14 x 7/8" XL Stitch Screw

PBR-PANEL ATTACHMENT

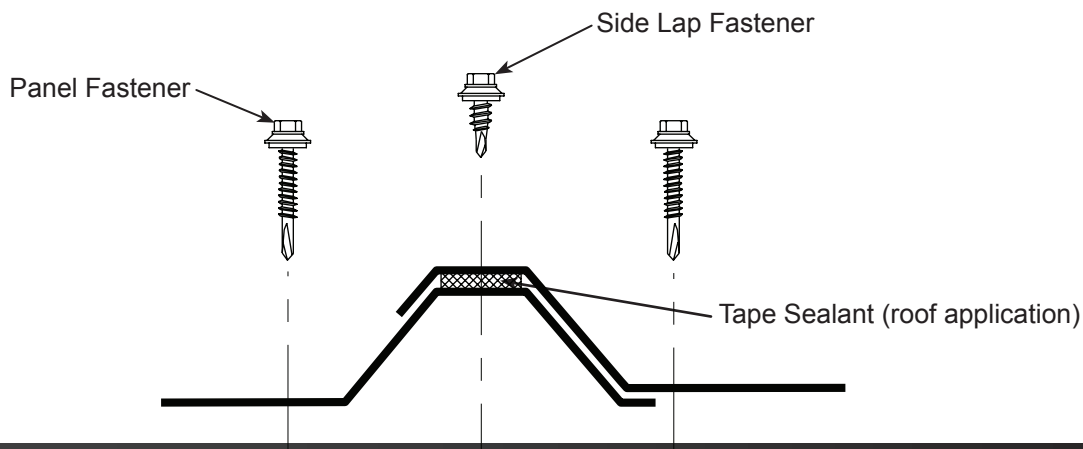

FASTENING PATTERNS

FIELD OF PANEL

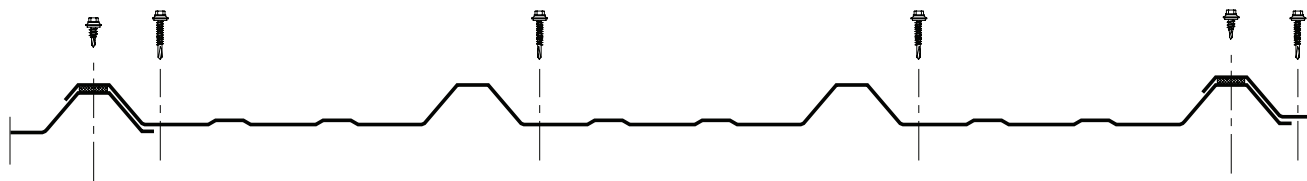

ENDS OF PANEL

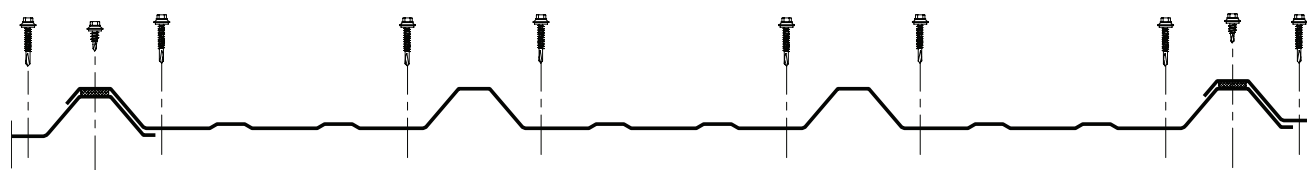

SECTION PROPERTIES

**ALLOWABLE UNIFORM LIVE LOADS, psf
For various fastener spacings**

Ga	Width in	Yield ksi	Weight psf	Top in Compression				Bottom in Compression				Inward Load						Outward Load					
				Ixx in ⁴ /ft		Sxx in ³ /ft		Ixx in ⁴ /ft		Sxx in ³ /ft		2'	3'	4'	5'	6'	7'	2'	3'	4'	5'	6'	7'
				Ixx	Sxx	Ixx	Sxx																
26	36	80	0.84	0.0367	0.0367	0.0317	0.0458	261	129	76	49	35	23	223	107	62	40	28	21				
24	36	50	1.09	0.0560	0.0579	0.0457	0.0613	330	153	88	57	39	29	314	145	83	53	37	27				
22	36	50	1.43	0.0800	0.0860	0.0633	0.0816	453	207	118	76	53	39	474	217	124	80	55	41				

1. Theoretical section properties have been calculated per AISI 2016 'North American Specification for the Design of Cold-Formed Steel Structural Members'. Ixx and Sxx are effective section properties for deflection and bending.
2. Allowable load is calculated in accordance with AISI 2016 specifications considering bending, shear, combined bending and shear & deflection. Allowable load does not address web crippling, fasteners, support material or load testing. Allowable load considers the three or more equal spans condition. Panel weight is not considered.
3. Deflection consideration is limited by a maximum deflection ratio of L/180 of span.
4. Allowable loads do not include a 1/3 stress increase for wind.

R-PANEL

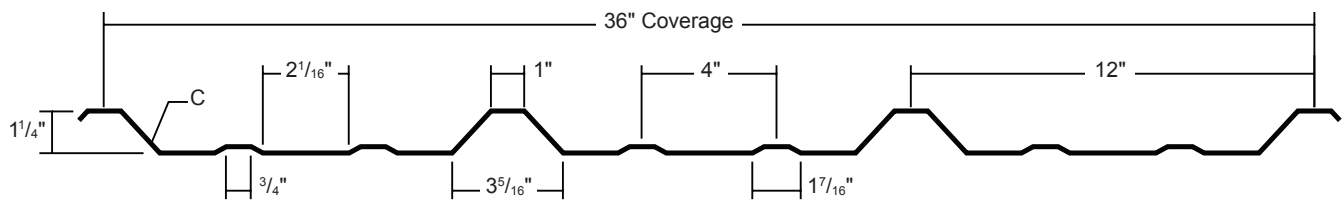

PANEL OVERVIEW

- Finishes: PVDF, MS Colorfast45° and Acrylic-Coated Galvalume®
- Corrosion Protection: AZ55 per ASTM A 792 for unpainted Galvalume®
AZ50 per ASTM A 792 for painted Galvalume®
G90 per ASTM A 653 for Galvanized
- Gauges: 26 ga and 24 ga standard; 22 ga optional
- 36" panel coverage, 1 1/4" rib height
- Panel Length: Minimum: 5'; Maximum: 45' recommended
- Exposed fastened metal building wall system
- Trapezoidal rib on 12" centers

TESTING AND APPROVALS

- UL 2218 Impact Resistance - Class 4
- UL 790 Fire Resistance Rating - Class A, per building code
- UL 263 Fire Resistance Rating - per assembly
- UL 580 Uplift Resistance - Class 90 Construction: #161
- Texas Windstorm - Evaluations RC-198 and RC-279
- 2023 FBC Approvals - FL9482.4 and FL14645.11
- Miami-Dade County, Florida NOA 20-0331.02 - Wall expires 4/22/2025
- ICC Evaluation Report - ESR-2385

FASTENING INFORMATION

- Overdriven fasteners will cause panel distortions.
- Fasteners should extend 1/2" or more past the inside face of the support material.
- Thick panels (ex. 18 ga) or supports (ex. 1/2" steel) may require predrilling of holes for screws.
- Panel Fastener:
 - Attaching to Wood:
 - #10-14 XL Wood Screw
 - Attaching to Steel:
 - #12-14 XL Self Drilling Screw
- Trim Fastener:
 - 1/4"-14 x 7/8" XL Stitch Screw

R-PANEL ATTACHMENT

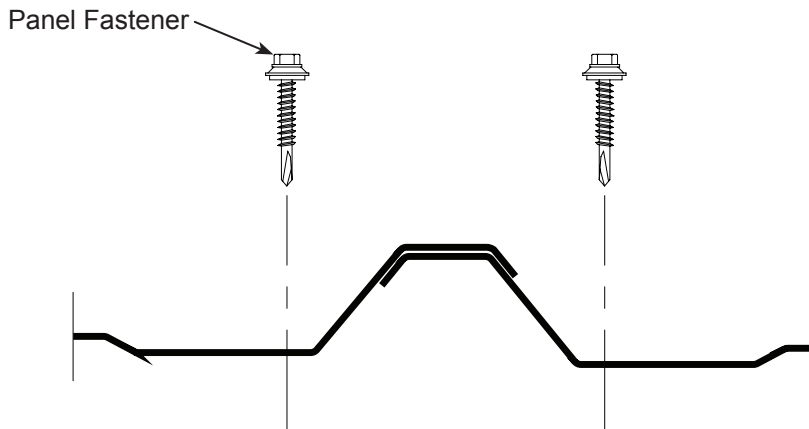

FASTENING PATTERNS

FIELD OF PANEL

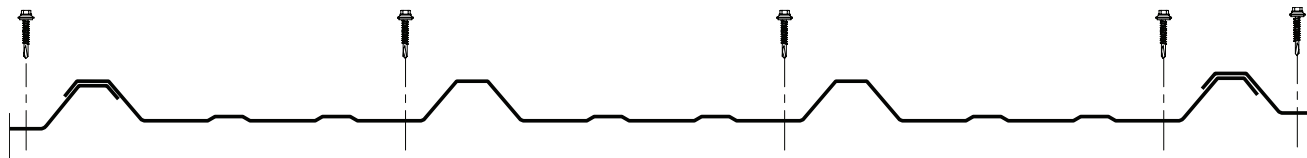

ENDS OF PANEL



SECTION PROPERTIES

ALLOWABLE UNIFORM LIVE LOADS, psf For various fastener spacings

Ga	Width in	Yield ksi	Weight psf	Top in Compression				Bottom in Compression				Inward Load						Outward Load					
				Ixx in ⁴ /ft		Sxx in ³ /ft		Ixx in ⁴ /ft		Sxx in ³ /ft		2'			3'			4'			5'		
				2'	3'	4'	5'	6'	7'	2'	3'	4'	5'	6'	7'	2'	3'	4'	5'	6'	7'		
26	36	80	0.80	0.0357	0.0357	0.0303	0.0448	245	123	73	48	34	23	211	102	60	39	27	20				
24	36	50	1.05	0.0543	0.0560	0.0437	0.0600	317	149	85	55	38	28	299	140	80	52	36	26				
22	36	50	1.38	0.0780	0.0822	0.0613	0.0798	437	201	115	74	51	38	448	207	118	76	53	39				

- Theoretical section properties have been calculated per AISI 2016 'North American Specification for the Design of Cold-Formed Steel Structural Members'. Ixx and Sxx are effective section properties for deflection and bending.
- Allowable load is calculated in accordance with AISI 2016 specifications considering bending, shear, combined bending and shear and deflection. Allowable load considers the 3 or more equal spans condition. Allowable load does not address web crippling, fasteners, support material or load testing. Panel weight is not considered.
- Deflection consideration is limited by a maximum deflection ratio of L/180 of span.
- Allowable loads do not include a 1/3 stress increase for wind.

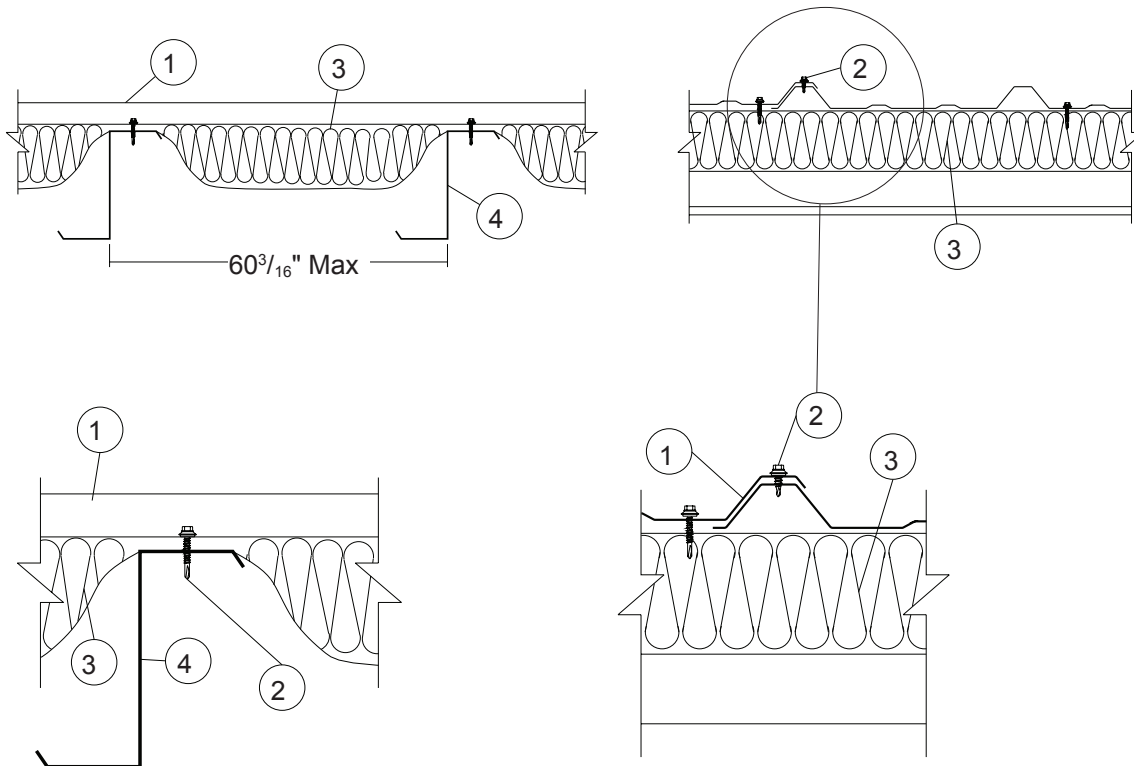

PBR-PANEL & R-PANEL

Construction No. 161
 November 02, 2001
 Uplift - Class 90
 Fire Not Investigated

1. Metal Roof Deck Pan No. 26 MSG min gauge coated steel. Panels continuous over two or more spans. End laps to occur over purlins with panels overlapped a min of 4 in. with lap centered over purlin web. A line of tape sealant may be used at panel side and end laps.

Metal Sales Manufacturing Corporation "R-Panel" "PBR-Panel".

2. Panel Fasteners For panel to panel and panel to purlin connections to be No. 12-14 by 1 in. self-drilling, self-tapping, hex head, plated steel screws with a 5/8 in. OD formed steel washer and a neoprene sealing washer.

As alternate Fasteners - For panel to purlin connections, 1/4 - 14 HHAB self-tapping, plating steel screws, with a separate 5/8 in. OD dome shaped steel washer and a neoprene sealing washer may be used.

Or: No. 14-10HHA, self-tapping, plating steel screws, with a separate, 5/8 in. OD dome shaped steel washer and a neoprene sealing washer may be used.

Spacing, for panel - to - purlin connections to be 12 in. on center beginning 2 - 1/2 in. from center line on one side of each major rib. Spacing at end lap to be in a 5 - 7 - 5 - 7 in. pattern beginning 2 - 1/2 in. from the center line on both sides of each major rib.

Fastener for panel to purlin connection to be 1-1/4 in. long when insulation (Item 3) is greater than 4-1/2 in.

Spacing for panel - to - panel connections to be 20 in. on center with a fastener located in line with the purlin fasteners.

3. Insulation (Optional) - Any compressible blanket insulation 6 in. max thickness before compression.

4. Purlin No. 16 MSG min gauge steel (50,000 psi min yield).

5. Lateral Bracing (Not shown) - As required.

Refer to General Information, Roof Deck Construction, (Roofing Materials and Systems Directory) for items not evaluated.

* Bearing the UL Classification Mark.



Underwriters Laboratories Inc. ®
 LISTED

Safety

Use proper safety gear, safe equipment and safe processes. Safety gear includes gloves, arm guards, safety goggles and fall protection. Safe equipment includes maintained screw gun, saw, snips and folder. Safe processes include being aware of dangers and taking appropriate measures to avoid them.

Material Storage

Material not used right away, should be stored inside, out of the elements. If inside storage is not available, tarp the material such that air can circulate. Elevate the crates off the ground and slope so that water will run off.

Wall Condition

Before installing panels, ensure the wall support material is plumb, square and true. Variance from in-plane should not exceed 1/4" in 10'.

Wall Assembly

Cover building envelope with a moisture barrier, such as peel-and-stick underlayment or synthetic building wrap to meet building code requirements for water resistance barrier to resist air and water penetration through the wall assembly. Install the moisture barrier horizontally from the bottom upward, overlapping each run over the previous, lower run.

Plan the Work

Before installing panels on a wall section, plan for alignment with adjacent wall sections. Decide if the first and last panels in the run should be a full or partial panel. Consider the locations of wall penetrations and openings.

Fasteners

Do not overtighten the panel fasteners. The fasteners should be brought just to firm contact between the support material and panel. Overtightening the fasteners can cause panel deformation.

The fastener spacing must be determined based on a load analysis to ensure adequate attachment. Stitch Screw in the side lap or field-applied sealant / adhesive is required to develop load-carrying capacity.

Installation Practice

For horizontal panels, start at the bottom of the wall and work up the wall toward the top. Always 'shingle' panels and trims so that water will run down off of one member on to the next. Ensure every surface has adequate slope to permit water to run off and not collect on any surface. Vertical panel may be installed left-to-right or right-to-left.

When installing panels, give effort to stay on module by checking the coverage of each panel and the overall modularity relative to the end of the run after every tenth panel.

Strippable Film

Fashings and trim are typically provided with strippable film as protection against minor fabrication, transit and handling damage. The strippable film must be removed just before installation. Waiting until after installation to remove the strippable film or after significant exposure to sunlight or heat can make removal very difficult.

EXPANSION AND CONTRACTION

PBR-Panel is a direct-fastened panel system. Fasteners throughout the system penetrate the panel and secure the system to the building framing. When the temperature of the panels increase, the panels lengthen. When the temperature of the panels decrease, the panels shorten. This change in length can adversely affect the fastener connections by loosening the embedment in the supporting member, by causing the fasteners to back-out, by breaking fasteners and by elongating the fastener hole in the panels.

Strategies to address the effects of thermal expansion and contraction include: use shorter panel runs, use a flexible support system, install fasteners in ribs rather than in the panel flat between the ribs, breakup long panel runs by introducing a roof step, use endlaps without fasteners through the endlap - allowing the panels to slide at the endlap and use a slope-change type flashing to bridge a gap between panels - allowing the panels to move independently, rather than using an endlap.

Thermal expansion and contraction should be considered on panels longer than 20'. Panel runs longer than 40' generally require some means of accommodating thermal expansion and contraction to avoid fastener issues.

RECEIVING MATERIAL

It is the responsibility of the installer to unload material from the delivery truck. The installer shall be responsible for providing suitable equipment for unloading of material from the delivery.

Metal Sales is not responsible for any damages or shortages unless they are documented in writing and presented to Metal Sales within 48 hours. A claim should be made against the carrier as soon as possible.

After receiving material:

- Check the condition of the material
- Review the shipment against the shipping list to ensure all materials are all accounted for
- If damages or shortages are discovered, it should be noted on the Bill of Lading at the time of delivery

GENERAL HANDLING

Each bundle should be handled carefully to avoid being damaged. Care should be taken to prevent bending of the panel or scratching of the finish. Whenever possible, the bundle should remain crated until it is located in its place of storage or use. If bundles must be opened, we recommend you re-crate them before lifting. To avoid damage lift the bundle at its center of gravity.

CAUTION

Improper loading and unloading of bundles and crates may result in bodily harm and/or material damage. Metal Sales is not responsible for bodily injuries and/or material damages resulting from improper loading and unloading.

MECHANICAL HANDLING

Forklift - A forklift may be used for panels up to 20'-0" long. Make sure the forks are at their maximum separation. Do not transport open bundles. When transporting bundles across rough terrain, or over a longer distance, some means of supporting the panel load must be used.

Crane - A crane should be used when lifting panels with lengths greater than 20'-0". Be sure to utilize a spreader bar to ensure the even distribution of the weight to the pick up points. As a rule when lifting panels, no more than $\frac{1}{3}$ of the length of the panel should be left unsupported. Never use wire rope because this will damage the panels.



UNSTACKING MATERIAL

For panels over 5'-0" in length at least two people on the ends of the panel are required. Additional help will be needed for every 10'-0" in length beyond that.

Take care when unstacking to ensure panels are lifted up and not across other panels in the stack. Minimize handling of panels when unstacking and stacking to avoid damage. Be sure to wear appropriate safety equipment including clean gloves, as panel edges are sharp.

Inspect panels before lifting. Metal Sales is not responsible for damage created by unstacking panels incorrectly. Dragging or sliding the panels will cause the corners and edges to scratch the paint.

Defect claims must be reported upon inspection and *before* panels are handled or installed.

Restacking – Align bottom-side edge with the stack and lay panel onto the stack, nesting with the panels.

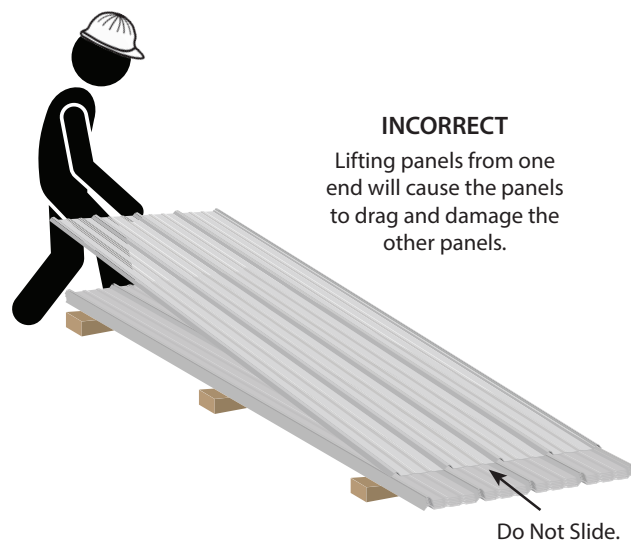
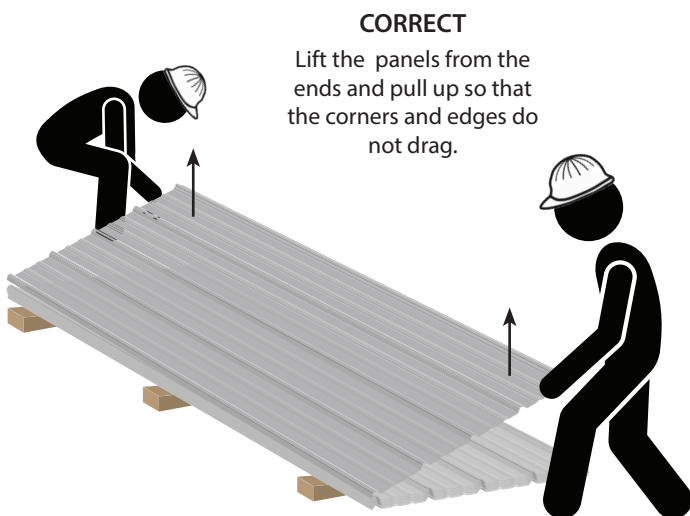

TRANSPORTING MATERIAL

Handling of individual panels should be done carefully and properly to avoid bending or damaging. Panels should be carried by grasping the edge so that the panel is vertical to the ground. Normally, individual panels can be handled by people placed every 6'-0" to 8'-0" along the length of the panel.

The panel should not be carried horizontal to the ground as this could cause the panel to buckle or bend in the center.

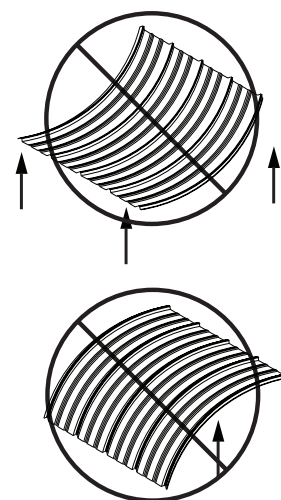
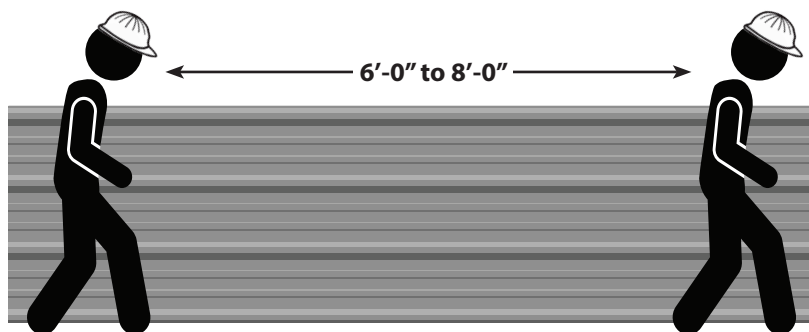

GENERAL

Please inspect panels for moisture accumulation. If moisture has formed, the panels should be unbundled, wiped dry, and allowed to dry completely. Once dry, carefully re-stack the panels and loosely recover allowing for ample air circulation.

Bundled sheets should be stored high enough off of the ground to allow for air circulation and prevent contact with accumulating water. Elevate one end of the bundle to allow any moisture to run off the panels. Metal Sales recommends covering the bundle with a tarp. Do not use tight fitting plastic-type tarps as panel bundle covers. While they may provide protection from heavy downpours, they can also retard necessary ventilation and trap heat and moisture that may accelerate metal corrosion. If panels are to be stored in possible bad weather, we suggest they be stored inside. Extended storage of panels in a bundle is not recommended. **Under no circumstances should the panels be stored near or come in contact with salt water, corrosive chemicals, ash or fumes generated or released inside the building or nearby plants, foundries, plating works, kilns, fertilizer and wet or green lumber.**

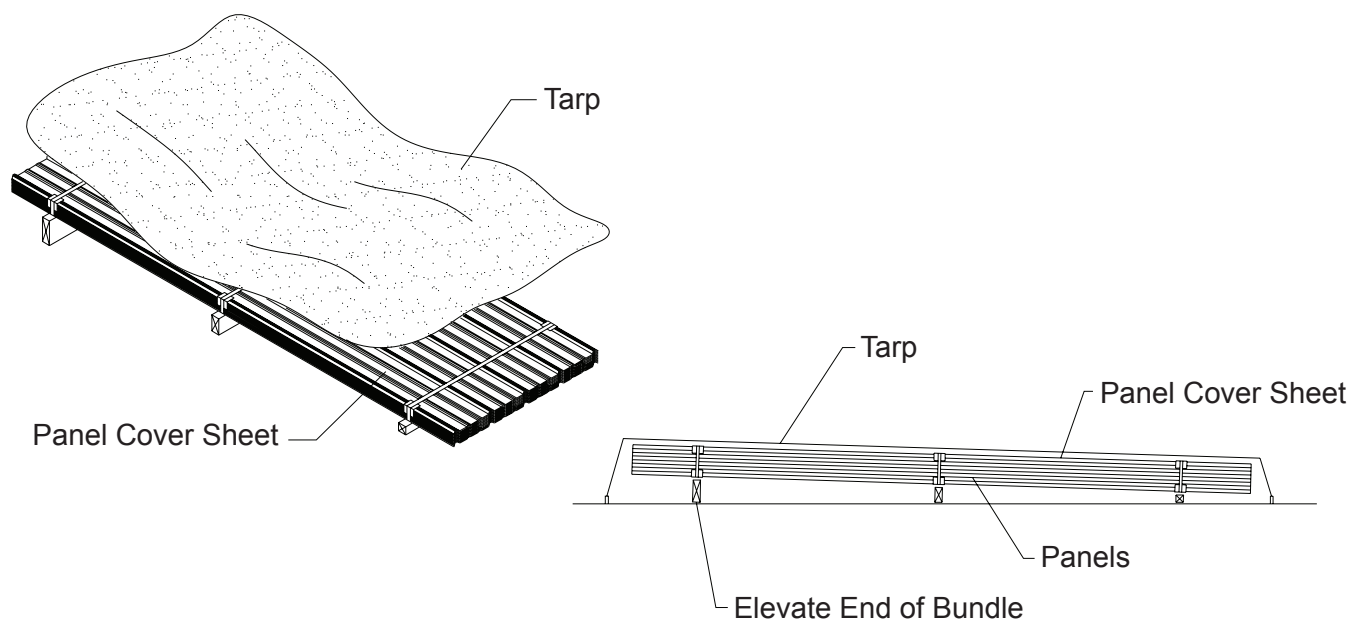

FOOT TRAFFIC

Care of metal panels and flashings must be exercised throughout erection. Foot traffic can cause distortion of panel and damage to finish. Traffic over the installed system must be kept to an absolute minimum. Installers should wear rubber sole shoes to keep from scuffing material while walking on the roof.

When walking on the roof panels is unavoidable, walk only in the flats of the panel. Walking on the ribs can cause damage to the panels.

REQUIRED TOOLS

Standard required tools for field installation include:

- Screw Guns
- Magnetic Bits
- Metal Nibbler or Shear
- Tin Snips
- Tape Measure
- Hammer
- Chalk Line
- Power Drill
- Drill Bits
- Pop Rivet Gun
- Safety Goggles
- Gloves
- Ear Plugs
- Fall Protection

CONDITION OF SUBSTRUCTURE

Metal Sales' panels are designed to be installed over open framing and/or directly over a wood substrate (minimum 5/8") with 30# felt moisture barrier (or an Ice and Water Shield when required by Local Building Codes).

Always check with local building codes prior to all installations for any additional requirements that may be specific to your area.

Galvanized and Galvalume panels should not be in contact with, or subject to, water runoff from copper, lead, or uncoated steel materials.

Condensate water from air conditioning units typically contains dissolved copper. This condensate should be discharged through a plastic pipe extended beyond the edge of the roof.

The roof should be inspected for any trapped moisture or structural damage such as bowing or sagging rafters and warped or loose roof purlins or solid decking. These areas should be repaired prior to installing new metal panels.

Prior to installation, make sure there are no nails or fasteners protruding from the roof framing or wood substrate which could damage the panels and impede the installation process.

When installed, panel distortion may occur if not applied over properly aligned and uniform substructure.

Whether installing over new or existing roof, the installer should check the roof deck for squareness before installing panels. Several methods can be used to verify squareness of the structure for proper installation of the panels.

METHOD "A" - One method for checking the roof for squareness is to measure diagonally across one slope of the roof from similar points at the ridge and eave and obtain the same dimension.

METHOD "B" - The 3-4-5 triangle system may also be used. To use this system, measure a point from the corner along the edge of the roof at a module of three (3). Measure a point from the same corner along another edge at a module of four (4).

By measuring diagonally between the two points established, the dimension should be exactly a module of five (5) to have a square corner. Multiple uses of this system may be required to determine building squareness. If the endwall cannot be made square, the roof system cannot be installed as shown in these instructions.

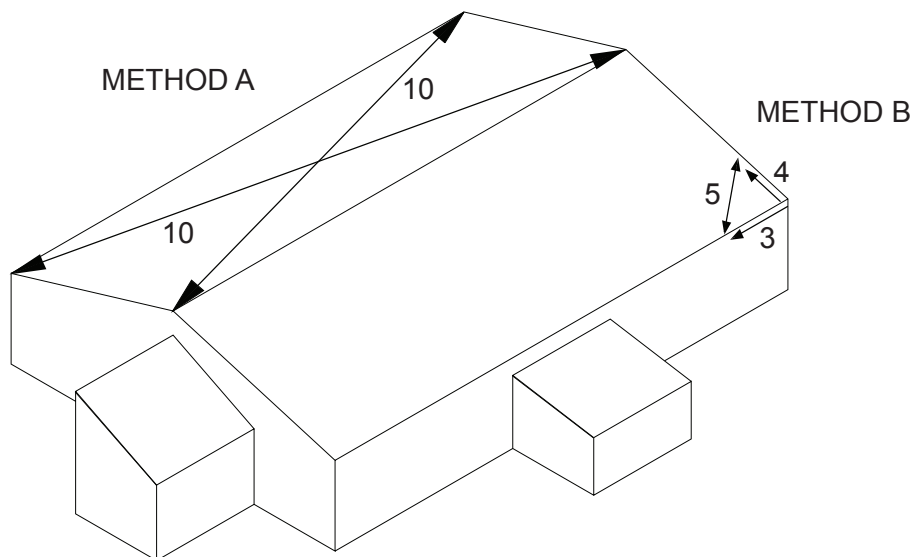

FIELD CUTTING

Tin snips or a "nibbler" type electric tool are recommended for field cutting metal panels. Cutting the steel generates slivers or metal chips. These slivers and metal chips must be immediately removed from the panels because they will damage the finish and shorten the life of the product.

One method of preventing this problem is to flip the panels over when cutting. This allows the slivers and metal chips to be brushed from the back side and avoids damaging the paint on the top side of the panels.

When cutting metal panels and flashings, goggles must be worn for eye protection.

CAUTION

All product surfaces should be free of debris at all times. Installed surfaces should be wiped clean at the end of each work period. Never cut panels over metal surfaces. Metal shavings will rust on the surface, voiding the warranty.

TOUCH-UP PAINT

All painted panels and flashings have a factory applied baked on finish. Handling and installing panels may result in some small scratches or nicks to the paint finish. Touch-up paint is available in matching colors from Metal Sales. It is recommended that a small brush be used to apply touch-up paint to those areas that are in need of repair. Touch-up paint does not have the superior chalk and fade resistance of the factory applied paint finish and will normally discolor at an accelerated rate. Aerosol paint should not be used because of the over-spray that may occur.



SPRAY PAINT

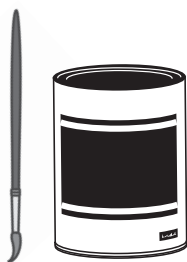

TOUCH-UP PAINT

CAUTION

Use as little Touch-up paint as possible. Paint will fade and there is no finish warranty with this product.

VENTILATION

Proper design and installation of vapor barriers and ventilation systems are important to prevent condensation and the resulting problems of moisture damage and loss of insulation efficiency.

Condensation occurs when moisture laden air comes in contact with a surface temperature equal to or below the dew point of the air. This phenomenon creates problems that are not unique with metal buildings; these problems are common to all types of construction.

The underside of the metal roof on a typical metal building (no attic) should be protected from condensation by insulating with a faced insulation. This should reduce the potential of condensation forming on the underside of the panels.

On buildings that have an attic space or are being retrofitted with a metal roofing system, vents should be placed at both the eave and peak of the roof in order to prevent a buildup of moisture (humidity) in the attic space.

Though factory applied pre-painted finishes are very durable and will last many years, eventually it may be desirable to thoroughly clean or repaint them.

Dirt pickup may cause apparent discoloration of the paint when it has been exposed in some dirt-laden environments for long periods of time. In areas of strong sunlight, slight chalking may cause some change in appearance. A good cleaning will often restore the appearance of these buildings and render repainting unnecessary. An occasional light cleaning will help maintain a good appearance.

In many cases, simply washing the building with plain water using a hose or pressure sprayer will be adequate. In areas where heavy dirt deposits dull the surface, a cloth or soft bristle brush and solution of water and detergent ($\frac{1}{3}$ cup of laundry detergent per gallon of water for example) may be used. This should be followed by an adequate rinse of water. Do not use wire brushes, abrasives, or cleaning tools which will damage the coating surface.

Mildew may occur in areas subject to high humidity but is not normally a problem due to the high inherent mildew resistance of the baked finish that is used. To remove mildew along with the dirt, the following solution is recommended.

- $\frac{1}{3}$ cup detergent (Tide® or equivalent)
- $\frac{2}{3}$ cup trisodium phosphate (Solex® or equivalent)
- 1 quart of 5% sodium hypochlorite solution (Clorox® or equivalent)
- 3 quarts of water

Strong solvents and abrasive type cleaners should be avoided. Most organic solvents are flammable and toxic and must be handled accordingly. When using a solvent, consult maintenance professionals and label instructions for proper handling and disposal of washings. If required, a mild solvent such as mineral spirits can be used to remove caulking compounds, oil, grease, tars, wax and similar substances. Use a cloth dampened with mineral spirits and apply only to areas which are contaminated. Follow up the use of this mild solvent with detergent cleaning and rinsing.

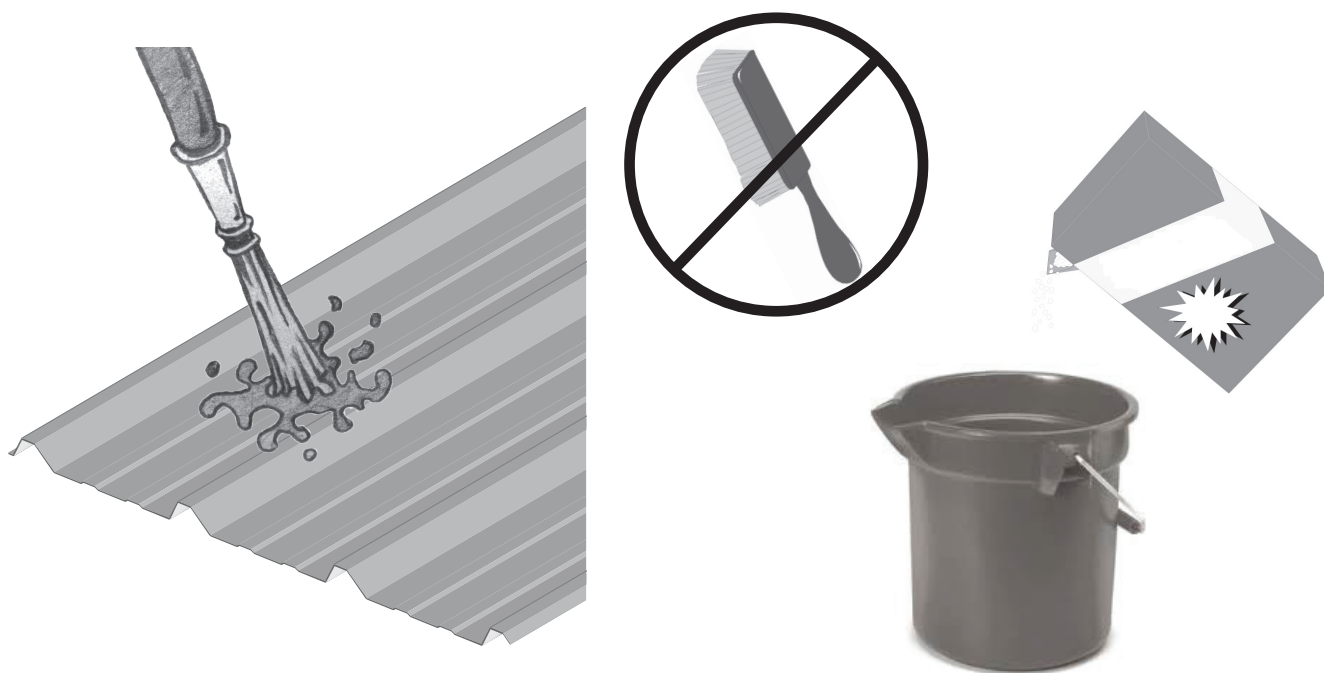

NOTES

- ▶ As shown below with the number designations, install panel against the prevailing wind. Installing Wall Panels first then Roof Panels
- ▶ To minimize corrosion, siding panels should not be installed all the way to the ground.
- ▶ Siding panels should lap over the foundations or splash boards at least three inches.
- ▶ Make sure panels are square and plumb, to assure straight and proper alignment of the entire row of panels.
- ▶ For areas with high wind considerations, closer fastener spacing may be required.
- ▶ It is necessary to attach a temporary guide to the foundation to use as an alignment guide when installing siding panels.

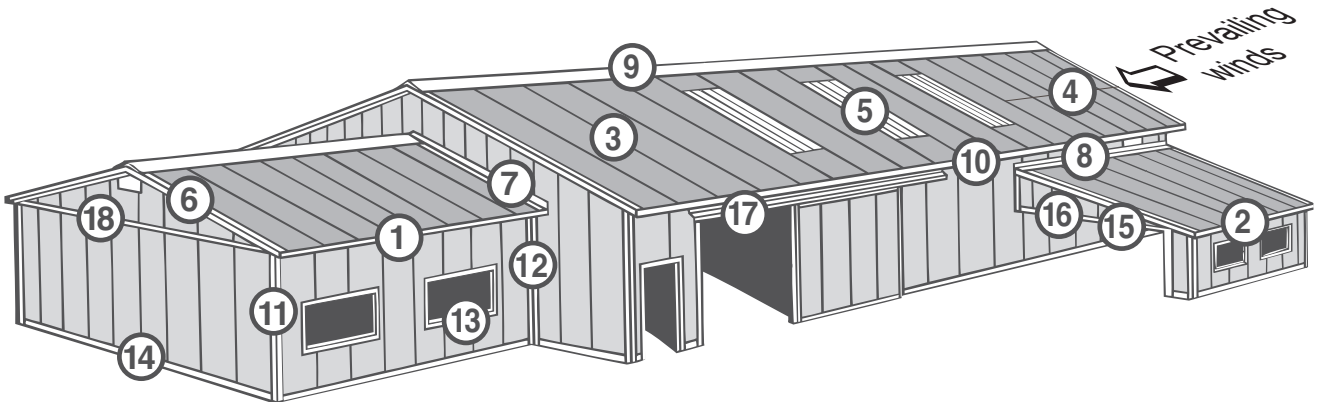

#	DETAIL	PAGE(S)	#	DETAIL	PAGE(S)
-	ms-HT Installation	43	8	Endwall	59
1	Eave Flashing	44	6	Sculptured Rake	60
1	Extended Eave	45	6	Rake	61
2	Box Gutter	46	-	Sculptured Peak	62
-	Valley	47	-	Sculptured Gutter	63
3	Panel Installation	48-49	11	PBR Outside Corner	64
4	Endlap	50-51	12	PBR Inside Corner	65
5	Light Transmitting Panels	52	11	Outside Corner	66
-	Rubber Roof Jack	53	12	Inside Corner	67
-	Formed Ridge	54	13	Jamb	68
-	Ridge/Hip Flashing	55	14	Base	69
9	Universal Ridge	55	15	Sill	70
9	Vented Ridge	56	16	Sill to Soffit	71
9	LP2 Vented Ridge	57	17	Head Channel	72
7	Rakewall	58	18	Wainscoting	73

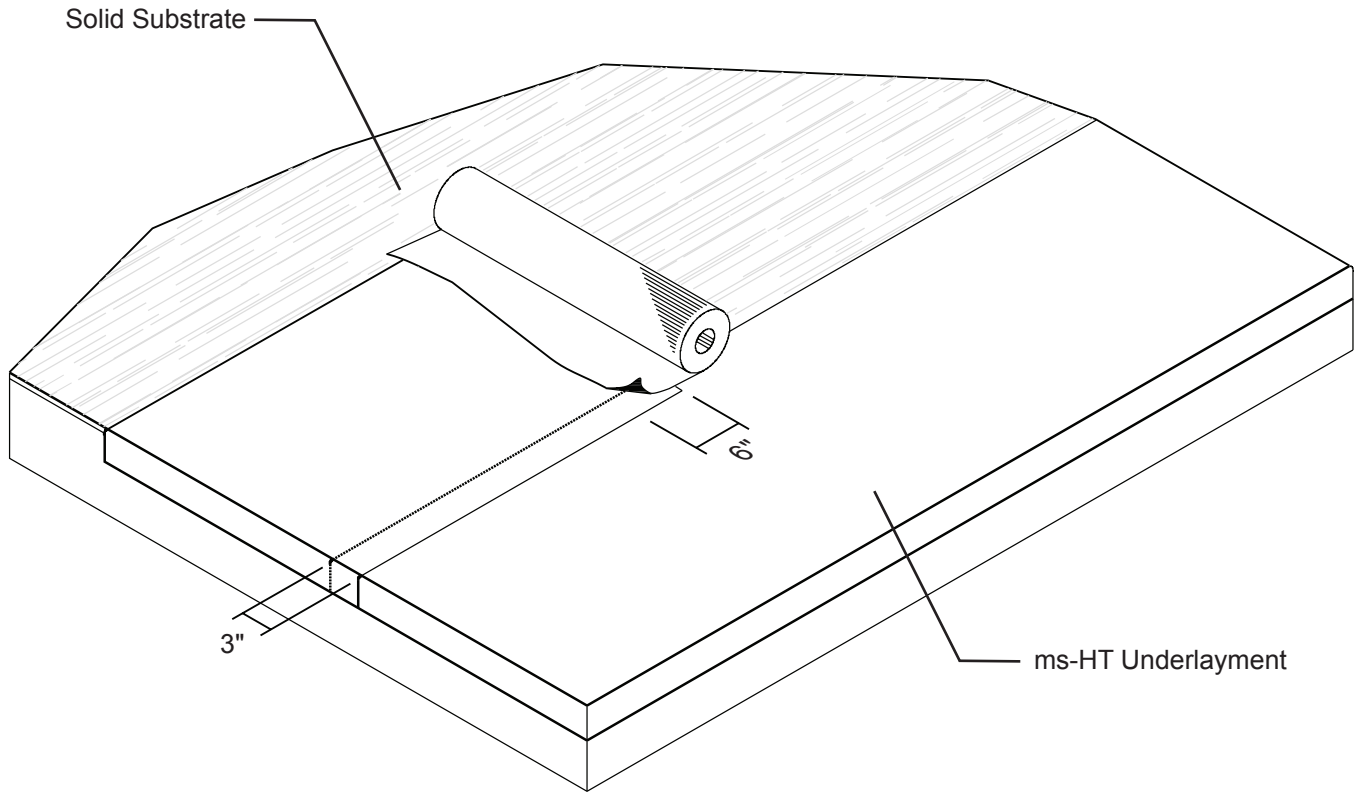

- ▶ Thickness: 40 mil
- ▶ Dimensions: 67' x 3'
- ▶ Gross Coverage: 200 ft²
- ▶ Net Coverage: 183 ft²
- ▶ Roll Weight: 45 lbs
- ▶ Installation Temperature: Above 50°

HIGH-TEMP UNDERLAYMENT

Note: ms-HT is a SBS modified bitumen self adhesive membrane intended to be used as a roofing underlayment. It has a slip resistant surface and will seal around penetrating fasteners.

1. Before installing the PBR-Panel roof it is recommended that ms-HT be installed on the solid substrate.
2. The ms-HT should extend over the edge of the roof surface a minimum of 2" on each side.
3. Start at the low side of the roof and roll out horizontally across the roof substructure.
4. If more than 1 roll is required as it is installed then the ms-HT must be endlapped a minimum of 6".
5. Once the bottom row is down and secure the next row is installed upslope of the first row. Lap the ms-HT a minimum of 3".

TESTING AND APPROVALS

FBC 2023: FL14392.1 Miami-Dade
 NOA: 20-0331.01, Expires 9/29/2025
 UL Evaluation Report: UL ER21824-01

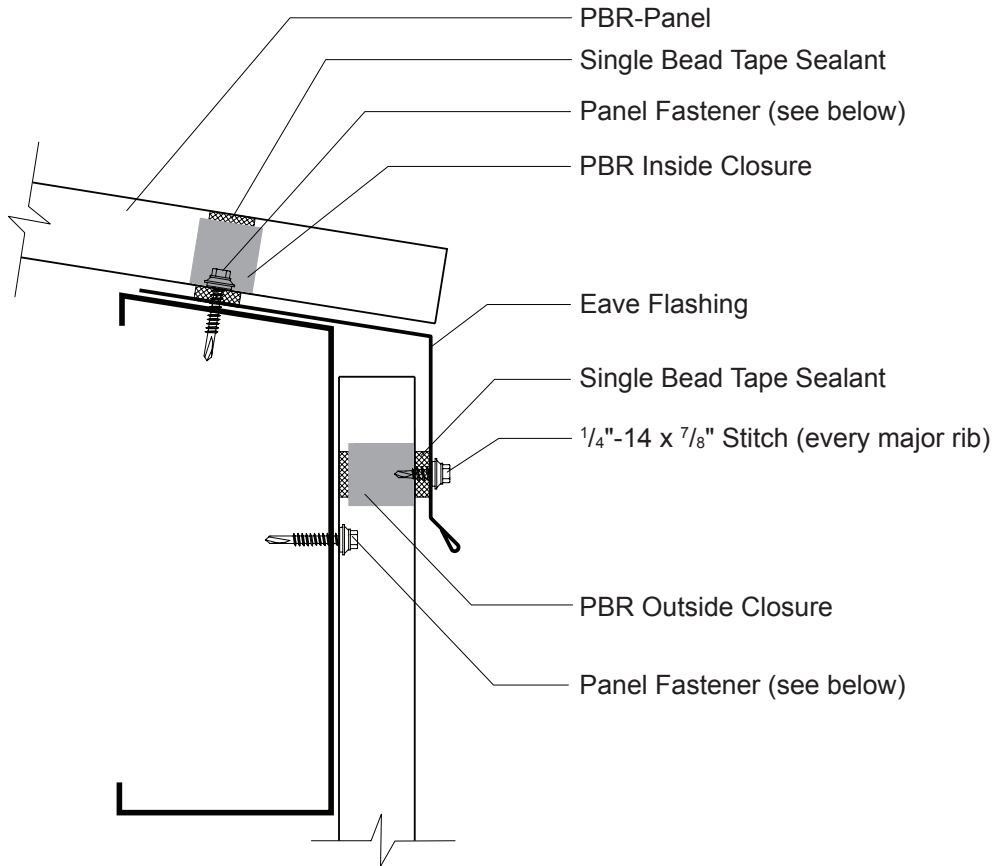

PANEL FASTENER INFORMATION

PBR-PANEL FASTENING PATTERN

Open Framing

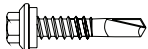

Self Driller
 #12-14 x 1"
 #12-14 x 1-1/2"
 #12-14 x 2"

Solid Wood Substrate

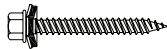

Woodscrew
 #10-14 x 1"
 #10-14 x 1-1/2"
 #10-14 x 2"

2X Wood Framing



Woodscrew
 #10-14 x 1"
 #10-14 x 1-1/2"
 #10-14 x 2"

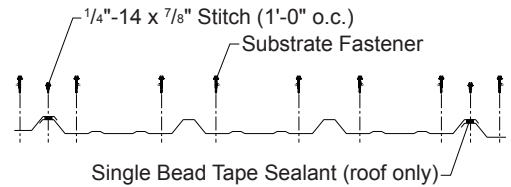

INSTALLATION STEPS

- Note: If you are installing an Eave Flashing where there is wall panel, the wall panel must be installed first.
1. Place the Eave Flashing at the eave and mark where the bottom of the Eave Flashing hits the wall panel.
 2. Apply a row of Single Bead Tape Sealant along the top of the wall panel so that it is above your mark and below the fasteners at the top of the wall panel.
 3. Place an Outside Closure or a Universal Closure over the Single Bead Tape Sealant.
 4. Apply a second row of Single Bead Tape Sealant to the outside face of the wall closures along the eave.
 5. Install the eave flashing flush against the wall panels, making sure to hide the closure, and fasten to the wall panel with a Stitch Fastener through the sealant and closure, at every major rib.
 6. Fasten the top of the Eave Flashing to the roof deck with the appropriate Pancake Head Fastener, 4' on center to hold the Extended Eave Flashing in place until the roof panels can be installed.

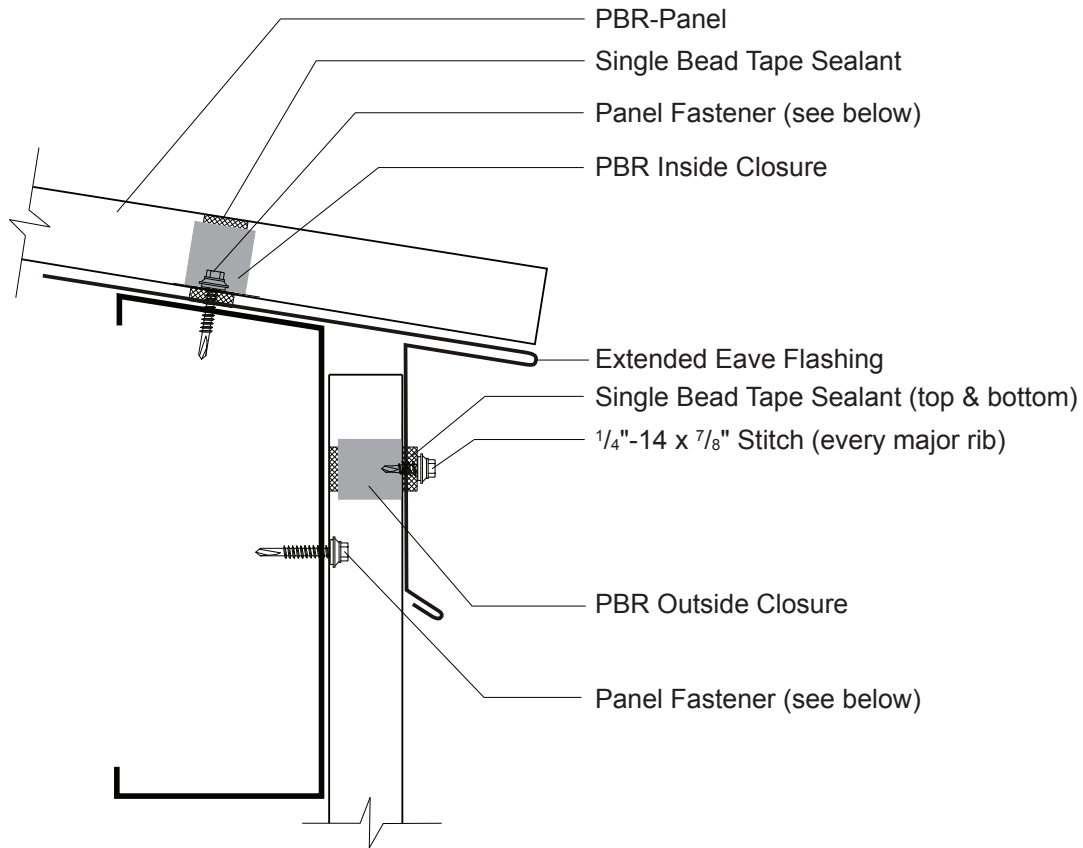

PANEL FASTENER INFORMATION

PBR-PANEL FASTENING PATTERN

Open Framing

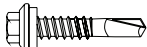

Self Driller
 #12-14 x 1"
 #12-14 x 1-1/2"
 #12-14 x 2"

Solid Wood Substrate



Woodscrew
 #10-14 x 1"
 #10-14 x 1-1/2"
 #10-14 x 2"

2X Wood Framing



Woodscrew
 #10-14 x 1"
 #10-14 x 1-1/2"
 #10-14 x 2"

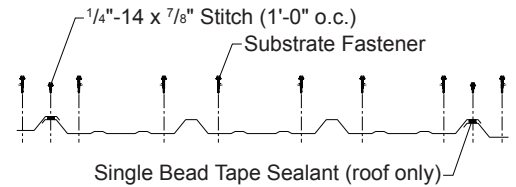

Note: If you are installing an Eave Flashing where there is wall panel, the wall panel must be installed first.

1. Place the Eave Flashing at the eave and mark where the bottom of the Eave Flashing hits the wall panel.
2. Apply a row of Single Bead Tape Sealant along the top of the wall panel so that it is above your mark and below the fasteners at the top of the wall panel.
3. Place an Outside Closure or a Universal Closure over the Single Bead Tape Sealant.
4. Apply a second row of Single Bead Tape Sealant to the outside face of the wall closures along the eave.
5. Install the eave flashing flush against the wall panels, making sure to hide the closure, and fasten to the wall panel with a Stitch Fastener through the sealant and closure, at every major rib.
6. Fasten the top of the Eave Flashing to the roof deck with the appropriate Pancake Head Fastener, 4'-0" on center to hold the Eave Flashing in place until the roof panels can be installed.

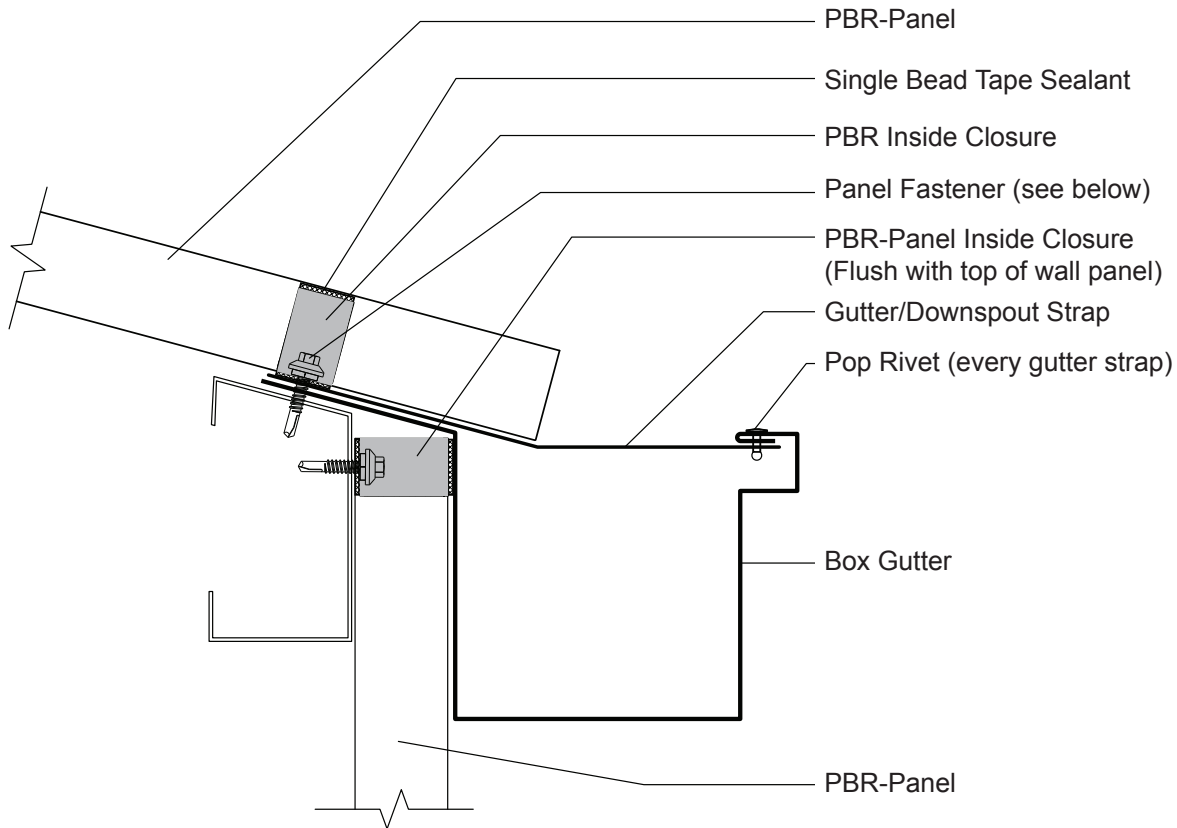

INSTALLATION STEPS

PBR-PANEL FASTENING PATTERN

Open Framing

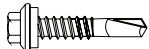

Self Driller
 #12-14 x 1"
 #12-14 x 1-1/2"
 #12-14 x 2"

Solid Wood Substrate



Woodscrew
 #10-14 x 1"
 #10-14 x 1-1/2"
 #10-14 x 2"

2X Wood Framing



Woodscrew
 #10-14 x 1"
 #10-14 x 1-1/2"
 #10-14 x 2"

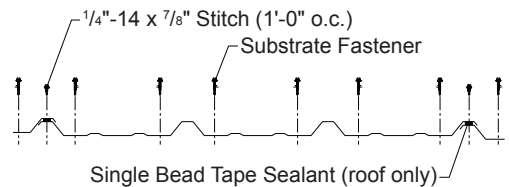

INSTALLATION STEPS

- Note: If you are installing an Box Gutter Flashing where there is wall panel, the wall panel must be installed first.
1. Place the Eave Flashing at the eave and mark where the bottom of the Eave Flashing hits the wall panel.
 2. Apply a row of Single Bead Tape Sealant along the top of the wall panel so that it is above your mark and below the fasteners at the top of the wall panel.
 3. Place an Outside Closure or a Universal Closure over the Single Bead Tape Sealant.
 4. Apply a second row of Single Bead Tape Sealant to the outside face of the wall closures along the eave.
 5. Install the eave flashing flush against the wall panels, making sure to hide the closure, and fasten to the wall panel with a Stitch Fastener through the sealant and closure, at every major rib.
 6. Fasten the top of the Eave Flashing to the roof deck with the appropriate Substrate Fastener, four feet on center to hold the Eave Flashing in place until the roof panels can be installed.

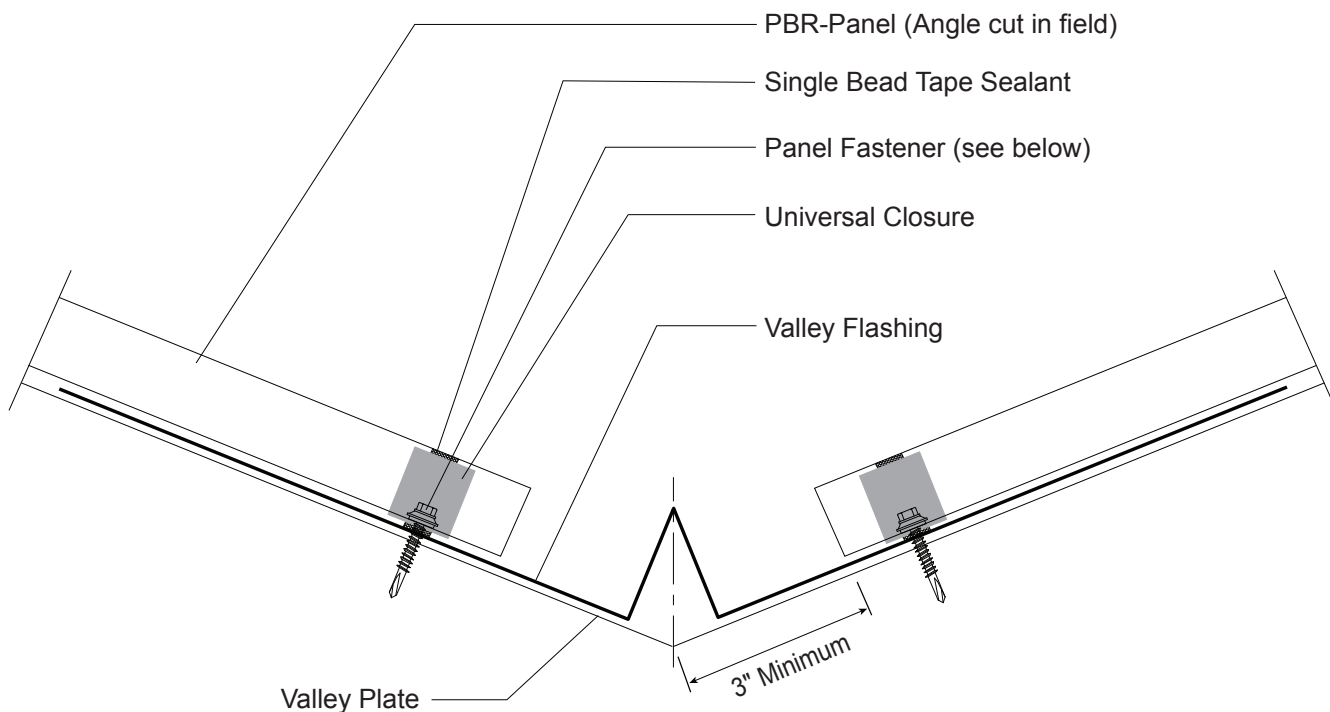

PANEL FASTENER INFORMATION

Open Framing

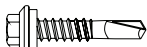

Self Driller
 #12-14 x 1"
 #12-14 x 1-1/2"
 #12-14 x 2"

Solid Wood Substrate



Woodscrew
 #10-14 x 1"
 #10-14 x 1-1/2"
 #10-14 x 2"

2X Wood Framing



Woodscrew
 #10-14 x 1"
 #10-14 x 1-1/2"
 #10-14 x 2"

PBR-PANEL FASTENING PATTERN

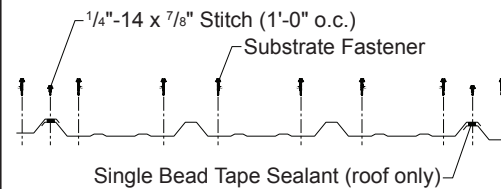

INSTALLATION STEPS

Note: It is recommended that ms-HT be installed under the valley flashing for added moisture protection.

1. If two or more valley flashings are required, the valley must be installed working from eave to peak, and they must be lapped a minimum of 6" with two continuous beads of Tube Sealant between them.
2. Do not install fasteners through the valley lap.
3. Place the Valley Flashing upside down at the eave of the building and mark the cut line for the valley angle. Cut the Valley flashing with Turbo-Shears starting from each side, working towards the center "V". Mark the center "V" as shown to allow extra material to cap off the end of the valley flashing. Cut with Turbo-Shears and Tin Snips. Bend the cut tabs in to close the V.
4. Apply a 3/8" bead of Tube Sealant along the Eave Flashings and place the Valley Flashing down.
5. Fasten the Valley Flashing to the roof deck with pancake head woodscrews 4' on center, on each side

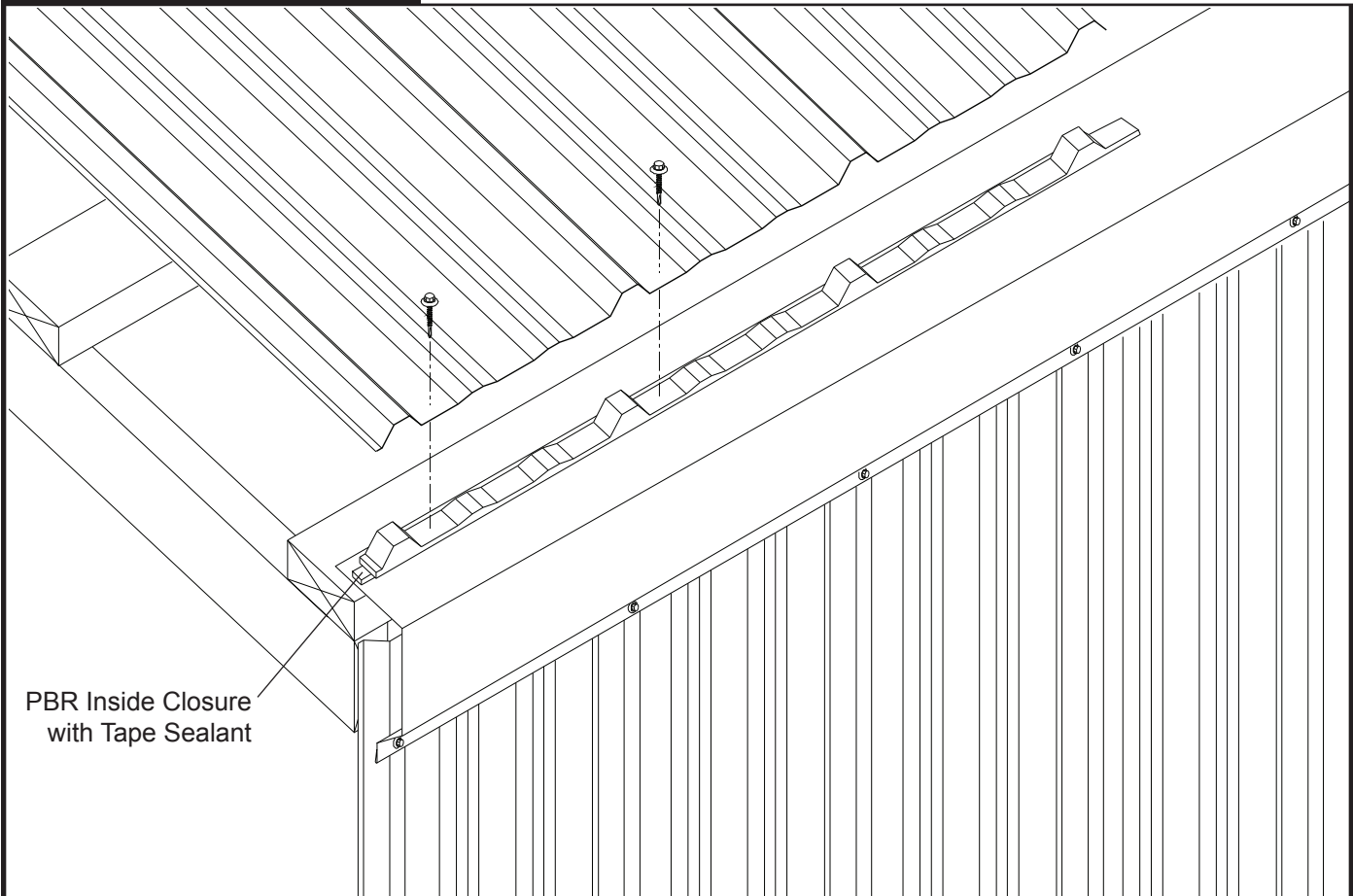

PBR Inside Closure with Tape Sealant

PANEL FASTENER INFORMATION

PBR-PANEL FASTENING PATTERN

Open Framing

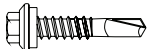

Self Driller
 #12-14 x 1"
 #12-14 x 1-1/2"
 #12-14 x 2"

Solid Wood Substrate



Woodscrew
 #10-14 x 1"
 #10-14 x 1-1/2"
 #10-14 x 2"

2X Wood Framing

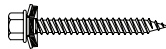

Woodscrew
 #10-14 x 1"
 #10-14 x 1-1/2"
 #10-14 x 2"

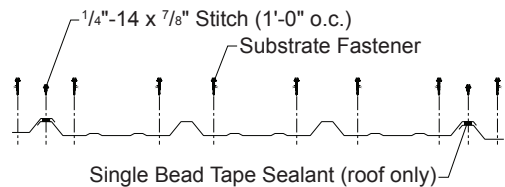

INSTALLATION STEPS

1. If your project has new or existing wall panels, you must consider adding additional overhang to your roof panels equal to the depth of the wall panels.
2. Turn the roof panel over and install a row of Single Bead Tape Sealant to the underside of the PBR-Panel. Place the PBR Inside Closure on top of the Single Bead Tape Sealant in the ribs on the underside of the panel. Install another row of Single Bead Tape Sealant to the bottom of the Inside Closure.
3. Turn the roof panel back over and make sure that it is square with the roof and lay it on the Eave Flashing.
4. The fastening pattern for roof panels at the panel ends, eave, gutter, ridge or highside eave and at the endlap is as shown.
5. These fasteners at the eave, gutter and endlap condition are installed through the Single Bead Tape Sealant into the roof deck.
6. Fasteners at the ridge and highside eave are installed one inch from the end of the panels.
7. For the field of the panel the fastening pattern is as shown.
8. For certain building codes and state or county specifications, special fastener spacing may be required.
9. Fasten woodscrews into the PBR-Panel as shown, one fastener on each side of each major rib.

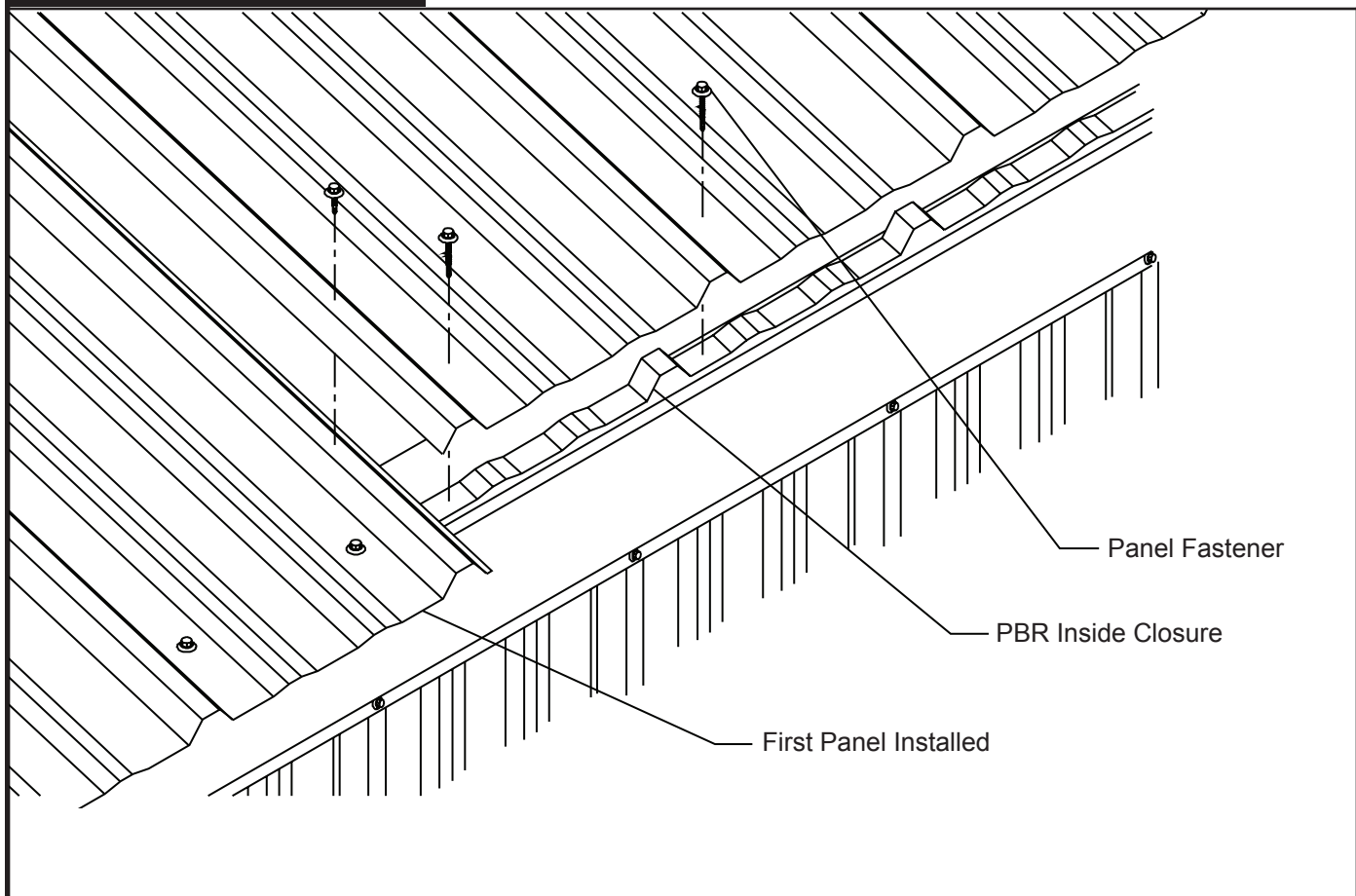

PANEL FASTENER INFORMATION

Open Framing

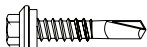

Self Driller
 #12-14 x 1"
 #12-14 x 1-1/2"
 #12-14 x 2"

Solid Wood Substrate



Woodscrew
 #10-14 x 1"
 #10-14 x 1-1/2"
 #10-14 x 2"

2X Wood Framing



Woodscrew
 #10-14 x 1"
 #10-14 x 1-1/2"
 #10-14 x 2"

PBR-PANEL FASTENING PATTERN

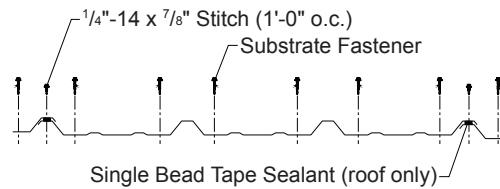

INSTALLATION STEPS

1. Before you install the next PBR-Panel, Single Bead Tape Sealant must be placed on the under lap rib of the previous panel.
2. Place the second panel on top of the previously installed panel covering the Single Bead Tape Sealant. Make sure that it is flush and square at the eave with the previous panel.
3. Install a Stitch Fastener on top of the lapping rib one foot on center through the sealant and the underlap rib.
4. Repeat this process for the remaining panels.
5. If you come to a valley condition, lay the panel down at the valley and mark the panel ribs to be cut. Snap a chalk line for the diagonal cut of the panel 3" from the center of the valley.
6. A Universal Closure is used instead of an Inside Closure at the valley condition.
7. Be sure to clean any debris or excess sealant before continuing the next section of the roof.

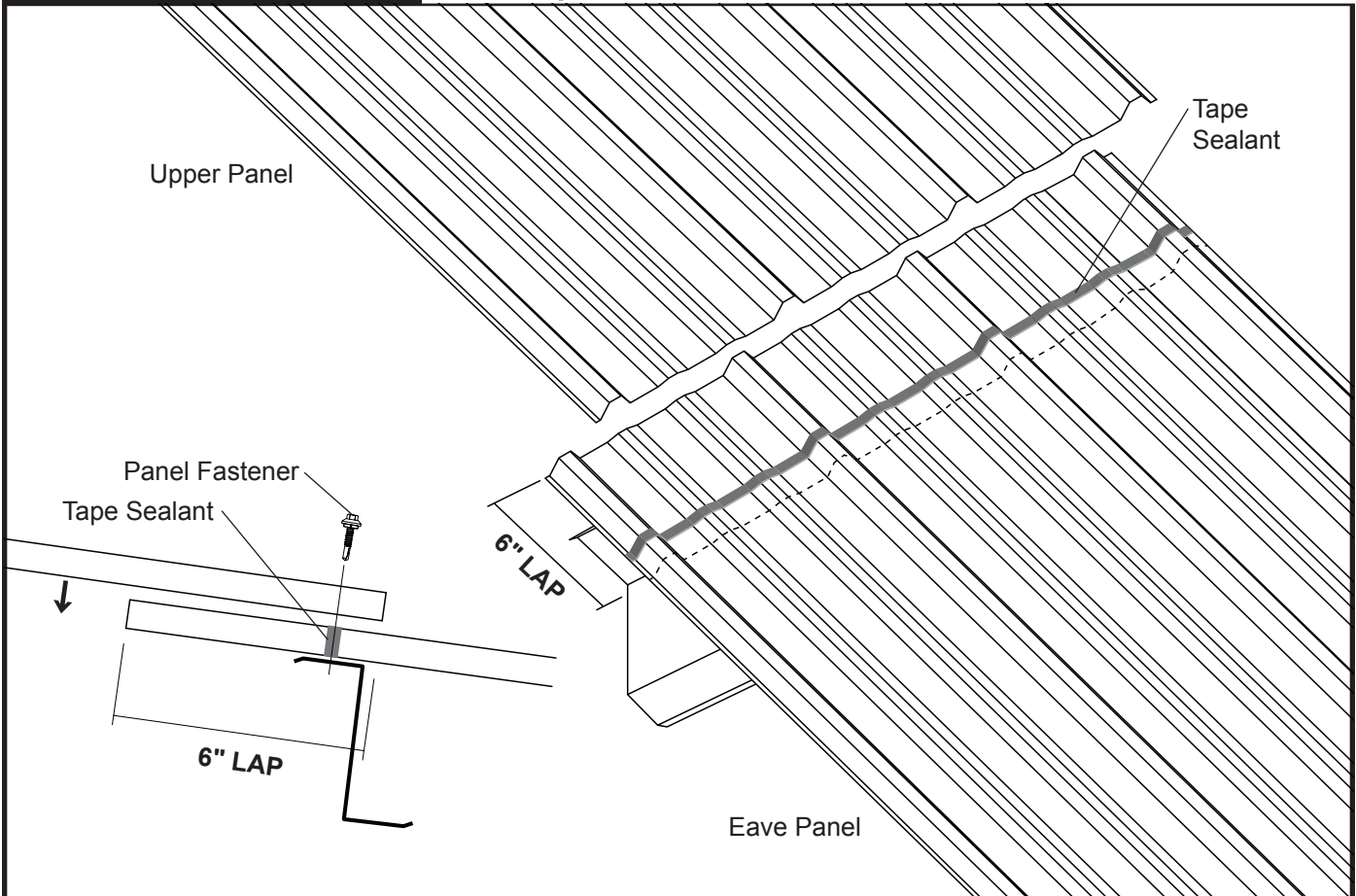

PANEL FASTENER INFORMATION

PBR-PANEL FASTENING PATTERN

Open Framing

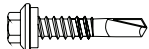

Self Driller
 #12-14 x 1"
 #12-14 x 1-1/2"
 #12-14 x 2"

Solid Wood Substrate

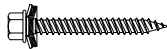

Woodscrew
 #10-14 x 1"
 #10-14 x 1-1/2"
 #10-14 x 2"

2X Wood Framing



Woodscrew
 #10-14 x 1"
 #10-14 x 1-1/2"
 #10-14 x 2"

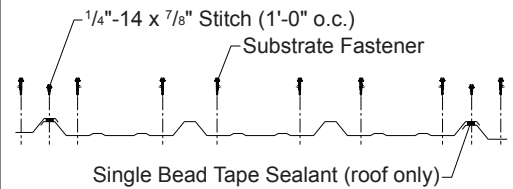

INSTALLATION STEPS

1. If more than one PBR-Panel is required on a panel run working eave to highside, then a panel endlap is required.
2. Start by installing all of the eave panels first. At the highside of the eave panels measure down 4" and apply a row of Single Bead Tape Sealant. Next apply another row of Single Bead Tape Sealant just above and below that first row.
3. Lap the highside panel over the eave panel a minimum of 6".
4. Measure up the highside panel and install woodscrews with the correct fastening pattern so that the fastener goes through the middle row of the tape sealant and into the roof deck.

STEP 1

- 1. Attach panel and apply Double Bead Tape Sealant on panel sidelaps.
- 2. Apply 1/4" bead of Tube Sealant 12" along the sidelap

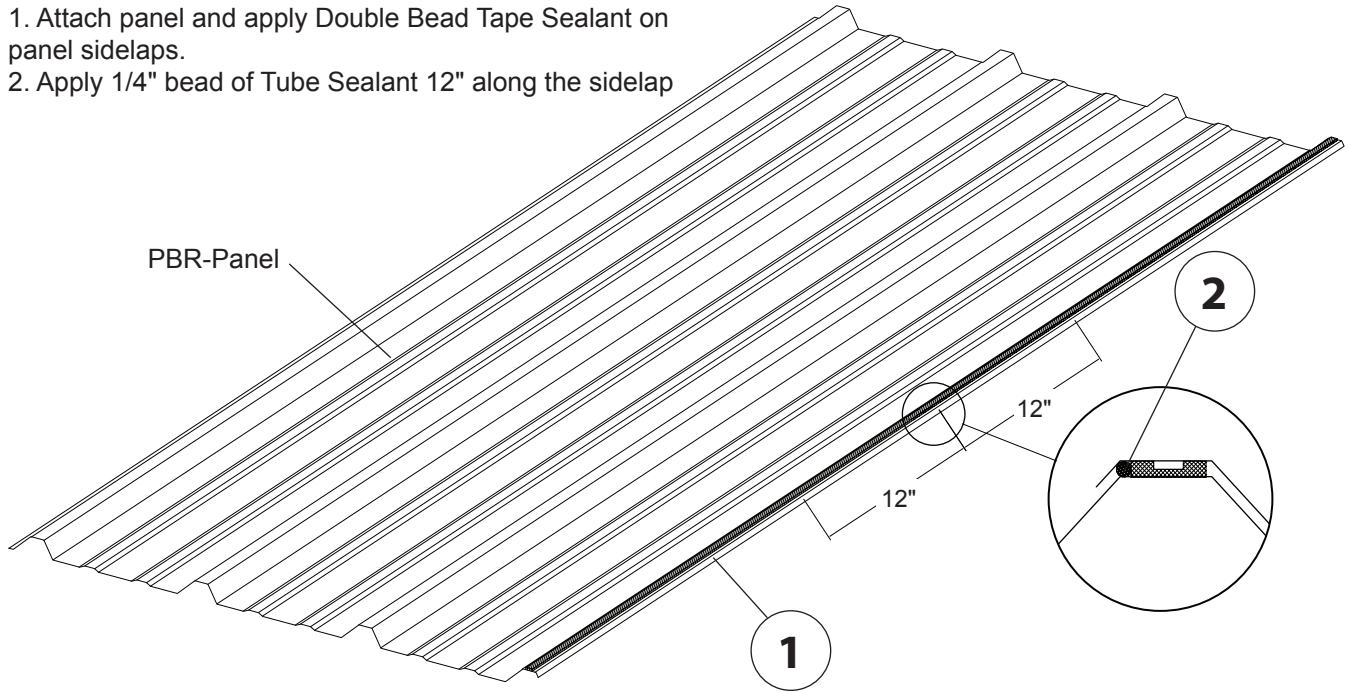

STEP 2

- 1. Apply Double Bead Tape Sealant across panel at Endlap 3" from the end of the panel.
- 2. Apply 1/4" bead of Tube Sealant 1" on each side of the tape sealant.
- 3. Apply 1/4" bead of Tube Sealant 12" along sidelap ribs.

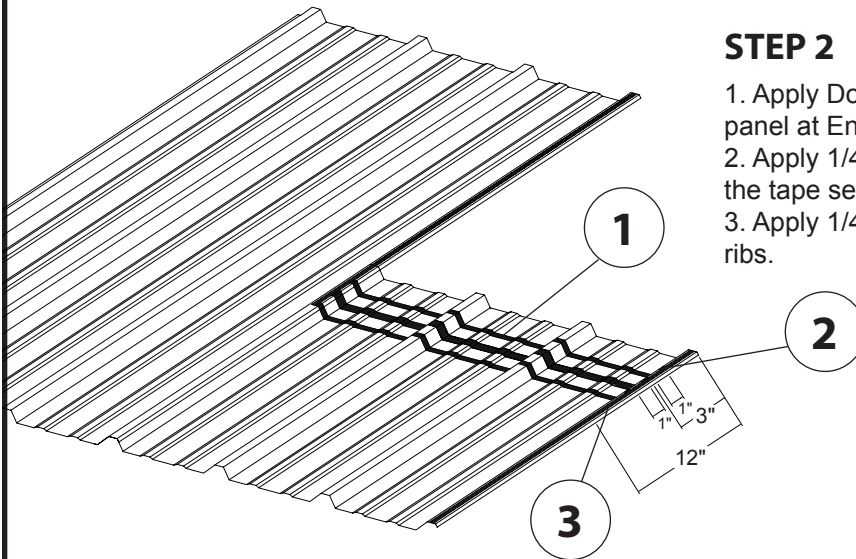

STEP 3

- 1. Attach panels / Endlap to supports. See overall panel endlap detail for fastener spacing.
- 2. Panel installation order.

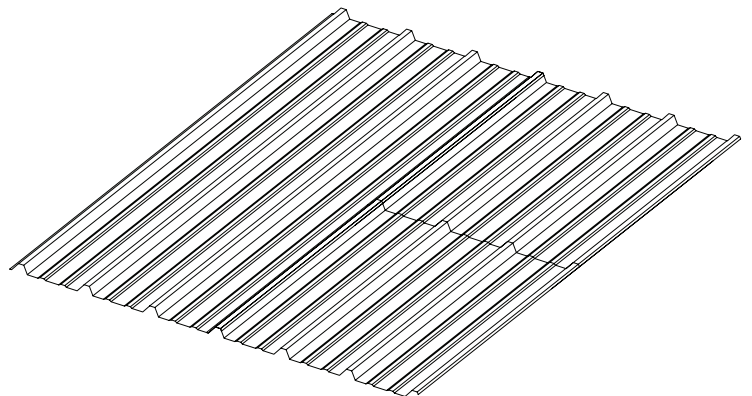
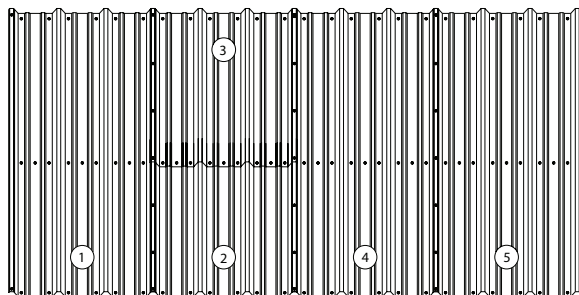

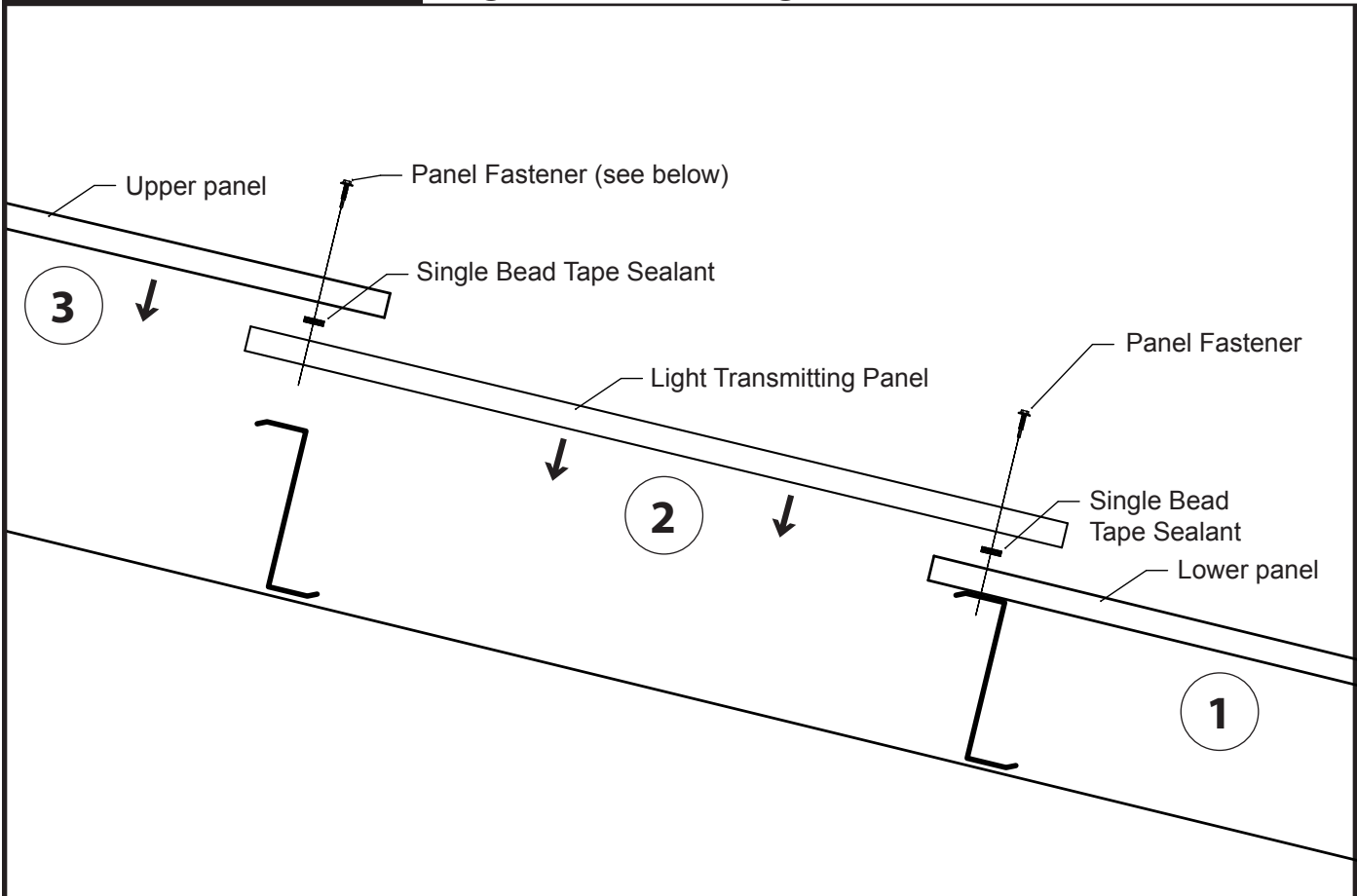

PANEL FASTENER INFORMATION

PBR-PANEL FASTENING PATTERN

Open Framing

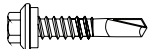

Self Driller
 #12-14 x 1"
 #12-14 x 1-1/2"
 #12-14 x 2"

Solid Wood Substrate



Woodscrew
 #10-14 x 1"
 #10-14 x 1-1/2"
 #10-14 x 2"

2X Wood Framing



Woodscrew
 #10-14 x 1"
 #10-14 x 1-1/2"
 #10-14 x 2"

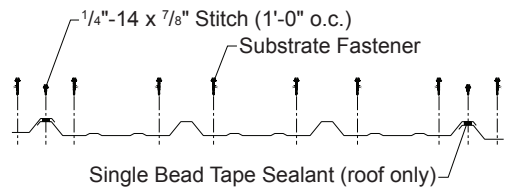

INSTALLATION STEPS

1. Install Lower Panel and fasten in place.
2. Prepare the endlap at the upper end of the Lower Panel by applying a bead of Single Bead Tape Sealant across the panel over the purlin.
3. Prepare the sidelap with adjacent panel by applying a bead of Single Bead Tape Sealant on to the underlap rib.
4. Pre-drill 1/4" diameter holes into Light Transmitting Panel to allow for differential expansion and contraction.
5. Install Light Transmitting Panel by putting it in place and installing Panel Fasteners at the Lower Panel and installing Stitch Screws, 1'-0" on center at adjacent sidelap rib.
6. Prepare the endlap at the upper end of the Light Transmitting Panel by applying a bead of Single Bead Tape Sealant across the panel over the purlin.
7. Install the upper panel and fasten in place.

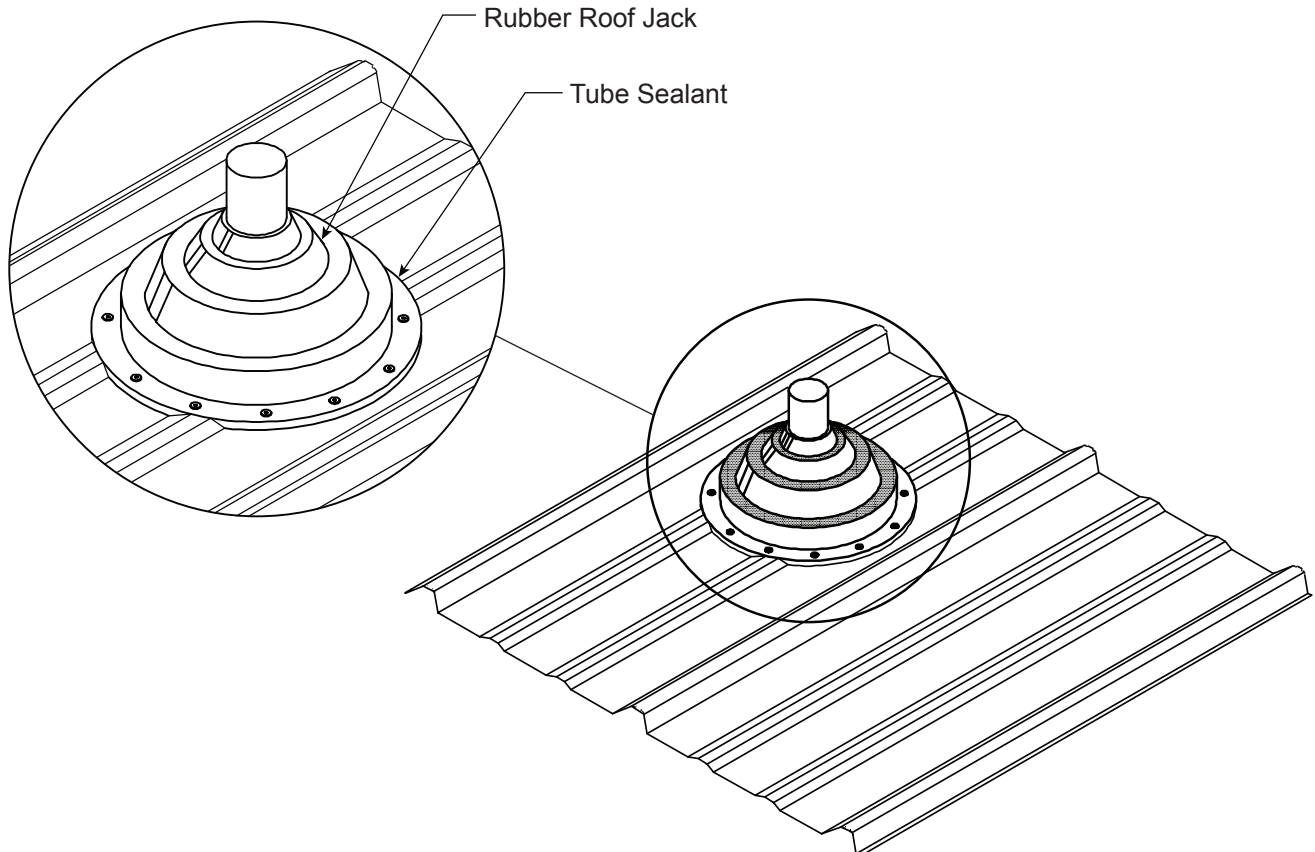

INSTALLATION STEPS

Note: Always abide by local plumbing codes when you're installing vent pipes

1. Areas around roof vents or rooftop units may show that corrosive fumes are emitted from a process within a building.
2. In the following example...the procedures are for vent pipes 6" or less and not transmitting extremely hot or caustic materials.
3. The vent pipe must extend through the flat of the roof panel so that the Rubber Roof Jack does not block the flow of water. If the vent pipe extension cannot be raised directly into the minor ribs of the new roof panel, use elbows to offset the pipe.
4. Determine the size and length of the vent pipe to be raised.
5. Take the appropriate measurements for the pipe size and vent location, mark them on the PBR-Panel and cut the hole in the panel.
6. When cutting the hole in the panel for the penetration make the radius of the hole 1/2" larger than the radius of the pipe. This will allow the panel to expand and contract around the penetration
7. Cut the top of the rubber roof jack so that it fits snug on the pipe. Slide the rubber roof jack onto the pipe all the way down until it is sitting on the roof panel.
8. If you are installing a square based rubber roof jack, make sure you turn it diamond shaped so the water runs around the side.
9. Lift the base of the rubber roof jack up so you can install tube sealant to the underside at the pipe.
10. Flip the rubber roof jack back down, flush with the panel
11. Bend up the base tabs of the rubber roof jack one side at a time and apply a bead of tube sealant. Repeat this with the other three sides of the rubber roof jack.
12. Attach the base of the rubber roof jack to the panel using stitch fasteners spaced 2" on center.
13. Apply tube sealant to the top of the rubber roof jack where it meets the pipe.

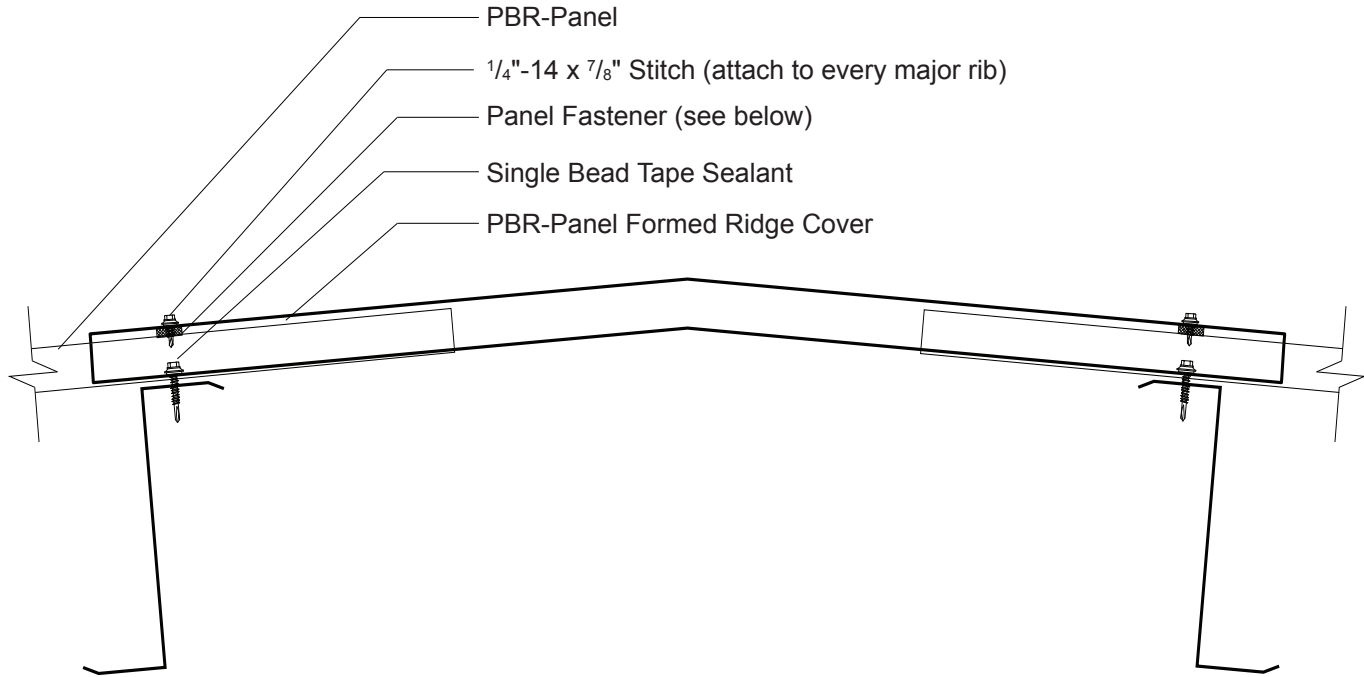

PANEL FASTENER INFORMATION

PBR-PANEL FASTENING PATTERN

Open Framing

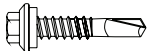

Self Driller
 #12-14 x 1"
 #12-14 x 1-1/2"
 #12-14 x 2"

Solid Wood Substrate



Woodscrew
 #10-14 x 1"
 #10-14 x 1-1/2"
 #10-14 x 2"

2X Wood Framing



Woodscrew
 #10-14 x 1"
 #10-14 x 1-1/2"
 #10-14 x 2"

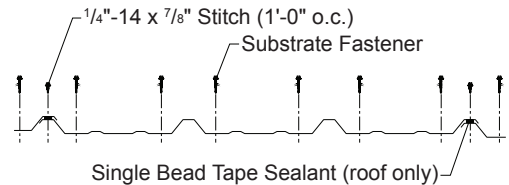

Note: It is critical that the panel ribs line up on both sides of the ridge before installing the Formed Ridge Flashing.

1. After installing and fastening in place the panel on one side of the ridge and before fastening in place the panels on the other side of the ridge, place the Formed Ridge on the panels to ensure the panel ribs align.
2. Once the panels on each side of the ridge are aligned and fastened in place, prepare for installing the Formed Ridge by applying a bead of Single Bead Tape Sealant across each panel at ridge over a purlin.
3. Prepare the sidelap with adjacent Formed Ridge by applying a bead of Single Bead Tape Sealant on to the underlap rib.
4. Install Formed Ridge by putting it in place and installing Panel Fasteners using the fastening pattern shown through the Single Bead Tape Sealant to attach the Formed Ridge to the panels.
5. Install Stitch Screws at the adjacent Formed Ridge fastening through the current Formed Ridge, Single Bead Tape Sealant and adjacent Formed Ridge. Space Stitch Screw 1'-0" on center.

PBR-PANEL

Ridge Hip

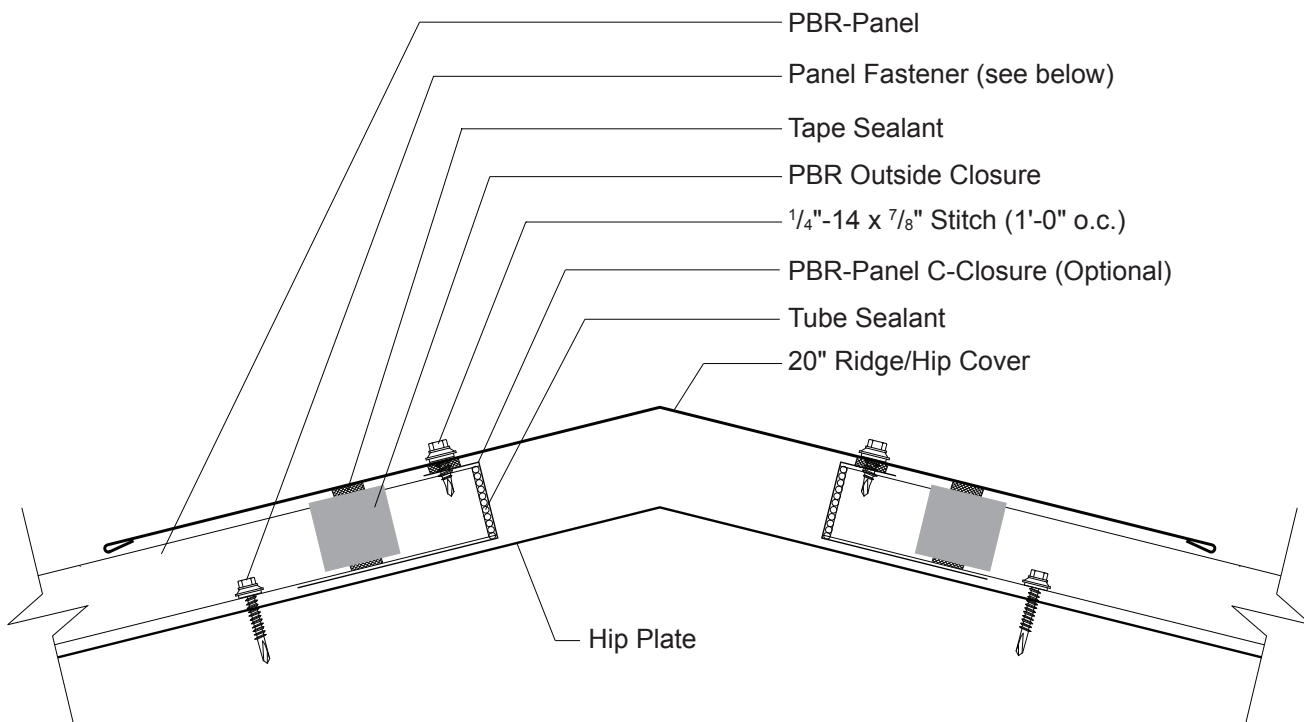

Universal Ridge

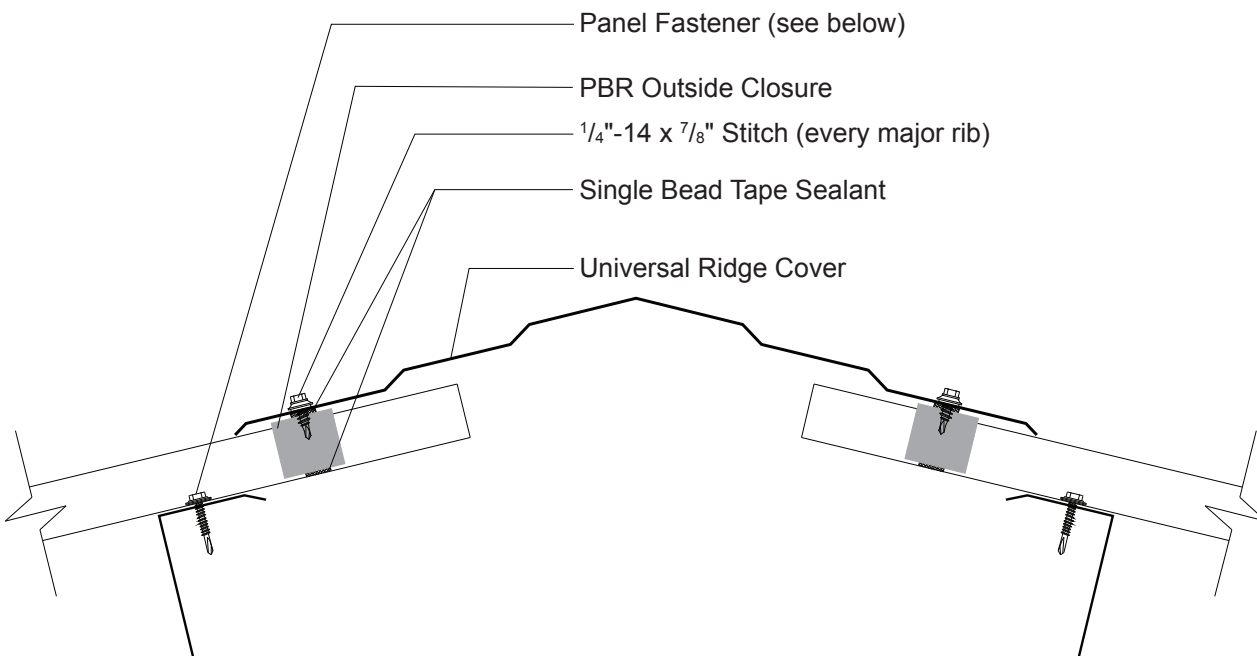

1. Place the Universal Ridge Cover on top of the PBR roof panels. Mark the edge location of both sides of the Universal Ridge Flashing. Place a row of Single Bead Tape Sealant 2" up from your mark, across the panel and over each panel rib on both sides of the ridge.
2. Place PBR Outside Closures on top of the outside closures along the length of the ridge.
3. Apply a second row of Single Bead Tape Sealant to the top of the PBR Outside Closures.
4. Place the Universal Ridge Flashing down on the ridge and fasten the Universal Ridge Flashing to the PBR-Panels through the PBR Outside Closures with Stitch Fasteners, one at every major rib.

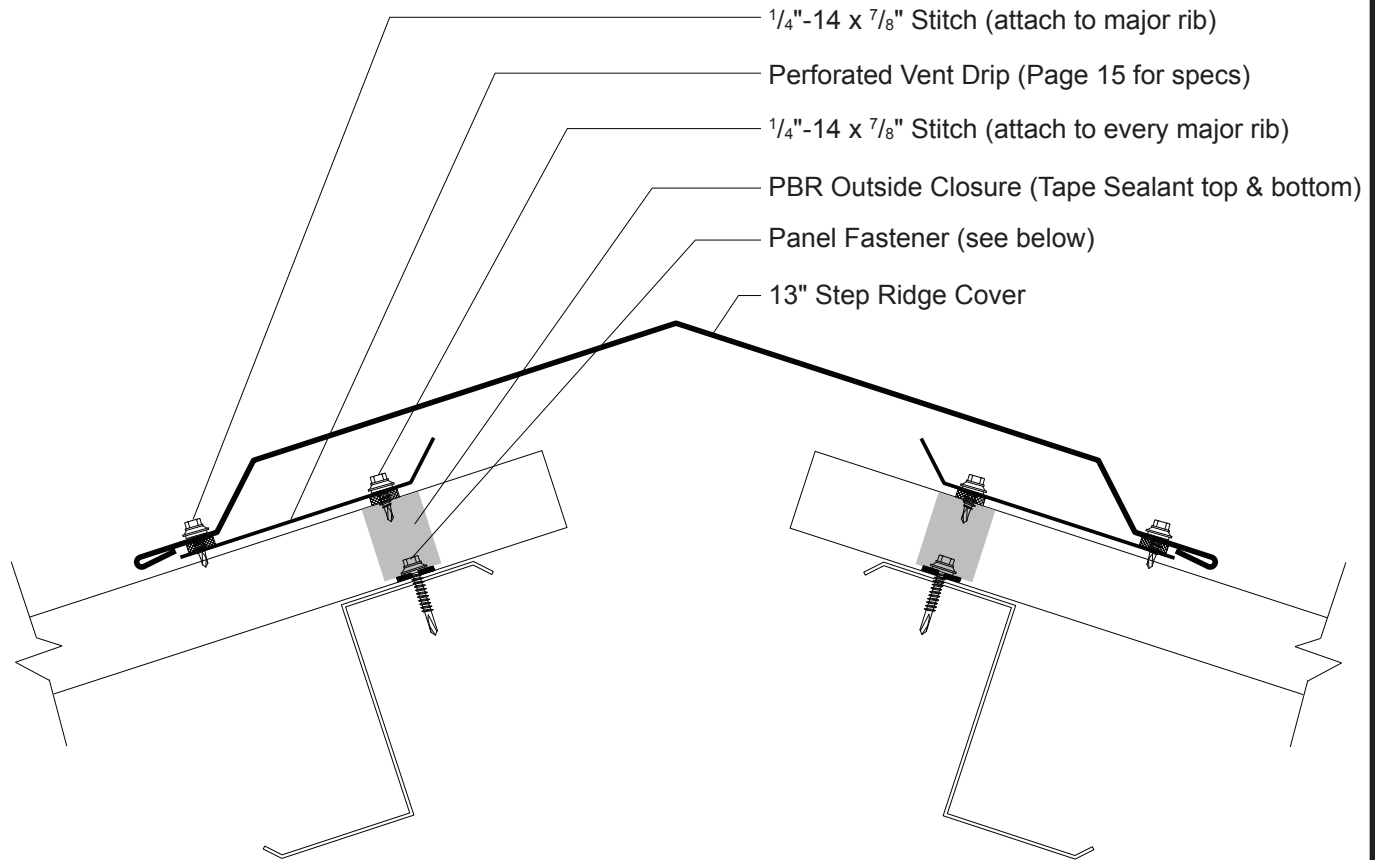

PANEL FASTENER INFORMATION

PBR-PANEL FASTENING PATTERN

Open Framing

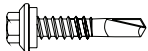

Self Driller
 #12-14 x 1"
 #12-14 x 1-1/2"
 #12-14 x 2"

Solid Wood Substrate

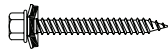

Woodscrew
 #10-14 x 1"
 #10-14 x 1-1/2"
 #10-14 x 2"

2X Wood Framing

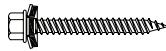

Woodscrew
 #10-14 x 1"
 #10-14 x 1-1/2"
 #10-14 x 2"

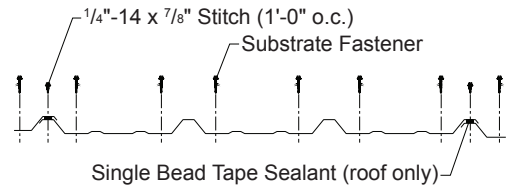

1. Place the 13" Step Ridge on top of the PBR roof panels. Mark where the edge of the ridge flashing hits the PBR roof panels on both sides of the ridge.
2. Place a row of Single Bead Tape Sealant across the panel and over each panel rib on both sides of the ridge.
3. Place Perforated Vent Drip along the length of the ridge. Be sure to place them so that the 13" Step Ridge will cover them.
4. Apply a second row of Single Bead Tape Sealant to the top of the Vented Closures.
5. Fasten the Universal Ridge Flashing to the PBR roof panels with Stitch Fasteners through the closure, one at every major rib.
6. End fasteners should be up slope of the vent material.

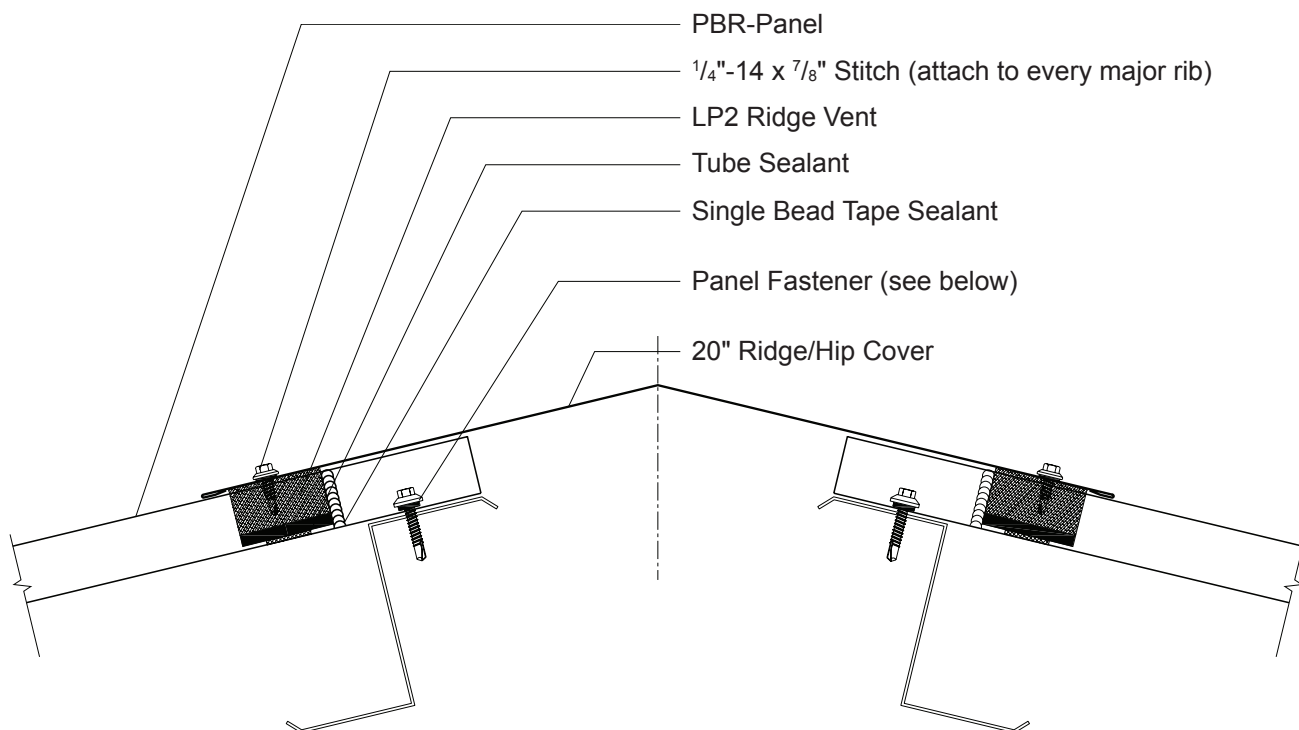

PANEL FASTENER INFORMATION

Open Framing

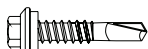

Self Driller
 #12-14 x 1"
 #12-14 x 1-1/2"
 #12-14 x 2"

Solid Wood Substrate



Woodscrew
 #10-14 x 1"
 #10-14 x 1-1/2"
 #10-14 x 2"

2X Wood Framing



Woodscrew
 #10-14 x 1"
 #10-14 x 1-1/2"
 #10-14 x 2"

PBR-PANEL FASTENING PATTERN

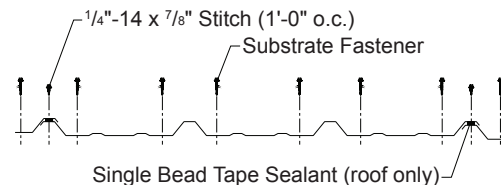

1. Place the Universal Ridge Cover on top of the PBR roof panels. Mark where the edge of the ridge flashing hits the PBR roof panels on both sides of the ridge.
2. Place a row of Single Bead Tape Sealant across the panel and over each panel rib on both sides of the ridge.
3. Place LP-2 Vented Closures along the length of the ridge. Be sure to place them so that the Universal Ridge Flashing will cover them.
4. Apply a second row of Single Bead Tape Sealant to the top of the Vented Closures.
5. Fasten the Universal Ridge Flashing to the PBR roof panels with Stitch Fasteners through the closure, one at every major rib.
6. End fasteners should be up slope of the vent material.

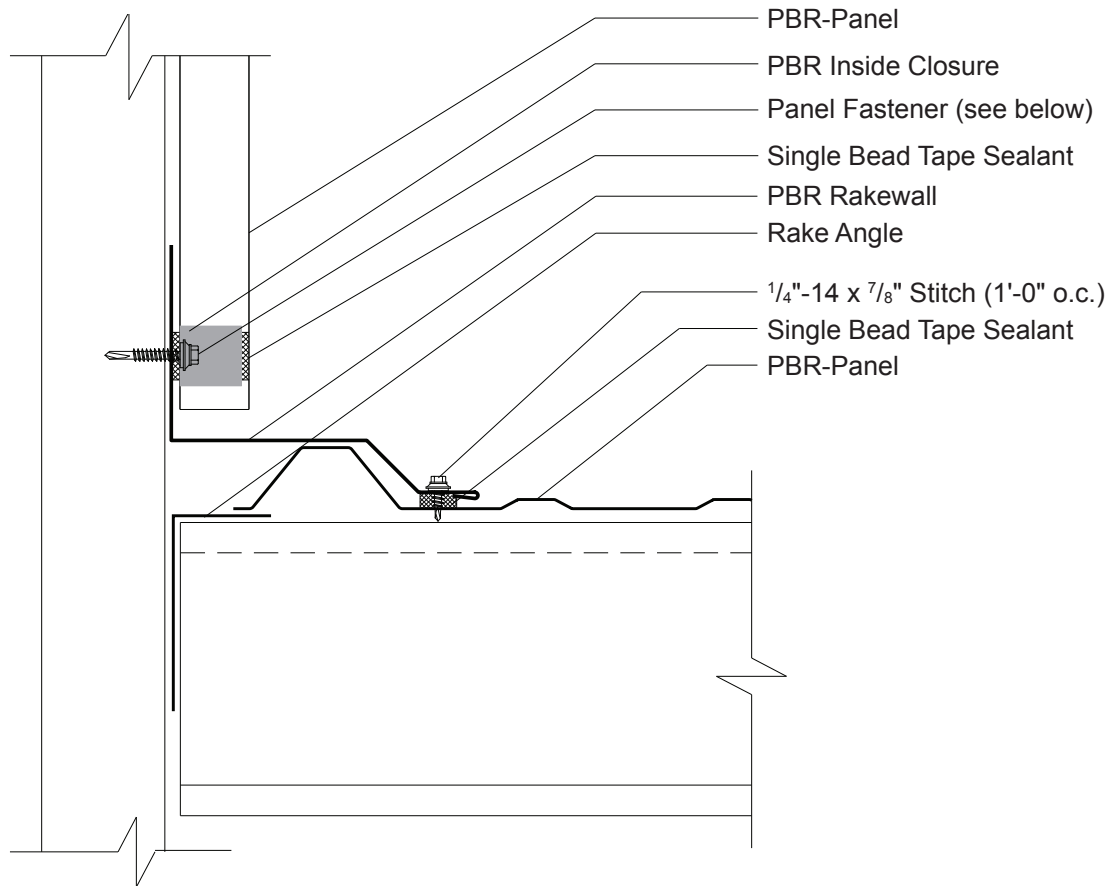

PANEL FASTENER INFORMATION

PBR-PANEL FASTENING PATTERN

Open Framing

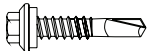

Self Driller
 #12-14 x 1"
 #12-14 x 1-1/2"
 #12-14 x 2"

Solid Wood Substrate

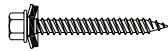

Woodscrew
 #10-14 x 1"
 #10-14 x 1-1/2"
 #10-14 x 2"

2X Wood Framing

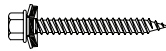

Woodscrew
 #10-14 x 1"
 #10-14 x 1-1/2"
 #10-14 x 2"

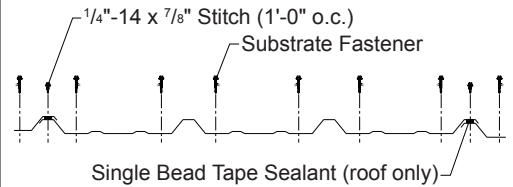

Note:

1. Place the Rakewall Flashing up against the wall and resting on the roof panel. Lightly mark the edge of the flashing on the roof panel.
2. Apply a row of Single Bead Tape Sealant on the major rib of the roof panel down the slope.
3. Lay the Rakewall Flashing down and fasten it to the PBR roof panel with a Stitch fastener 1'-0" on center.
4. Now fasten the top of the Rakewall Flashing to the wall.
5. Install the counter flashing, reglet or wall panel and fasten to the parapet wall with the appropriate fastener one foot on center. If counter flashing or reglet is used, seal it to parapet wall with tube sealant.

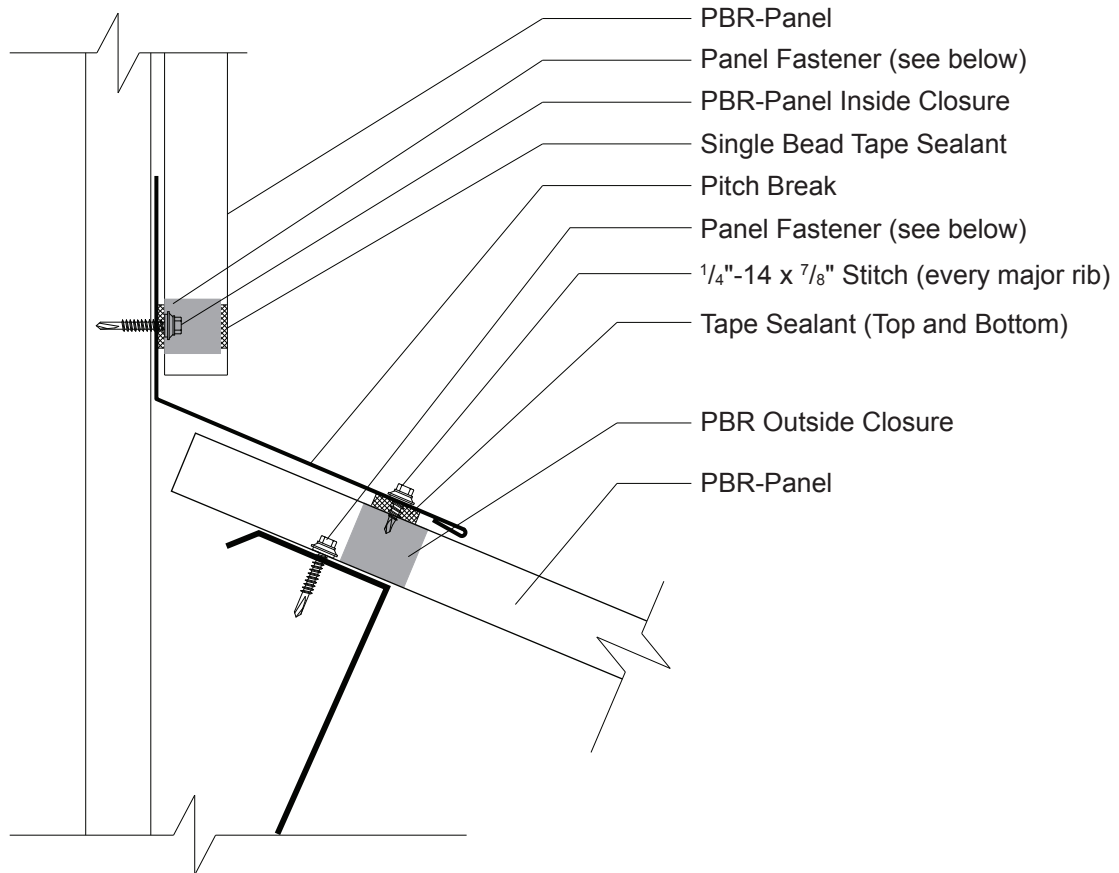

PANEL FASTENER INFORMATION

PBR-PANEL FASTENING PATTERN

Open Framing



Self Driller
 #12-14 x 1"
 #12-14 x 1-1/2"
 #12-14 x 2"

Solid Wood Substrate



Woodscrew
 #10-14 x 1"
 #10-14 x 1-1/2"
 #10-14 x 2"

2X Wood Framing



Woodscrew
 #10-14 x 1"
 #10-14 x 1-1/2"
 #10-14 x 2"

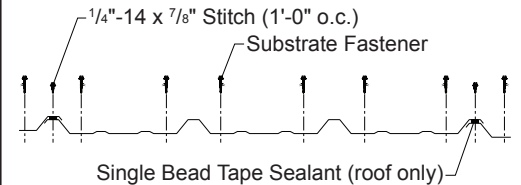

Note:

1. Place the Pitch Break Flashing on top of the PBR roof panels. Mark where the edge of the Pitch Break Flashing hits the PBR roof panels, upslope of your mark and downslope of the end fasteners, place a row of Single Bead Tape Sealant across the panel and over each panel rib.
2. Place PBR Outside Closures on top of the Single Bead Tape Sealant.
3. Apply a second row of Single Bead Tape Sealant to the top of the PBR Outside Closures.
4. Fasten the Pitch Break Flashing to the PBR roof panels through the PBR Outside Closures with Stitch Fasteners, one at every major rib.
5. Now fasten the top of the Pitch Break Flashing to the wall or behind the wall panel.
6. Install the counter flashing...reglet....or wall panel....and fasten to the parapet wall with the appropriate fastener one foot on center. If counter flashing or reglet is used, seal it to parapet wall with tube sealant.
7. If two or more flashings are required...lap the flashing over the previously installed flashing by a minimum of two inches. Place a two beads of tube sealant between the flashings and secure with pop rivets 2-1/2" on center.

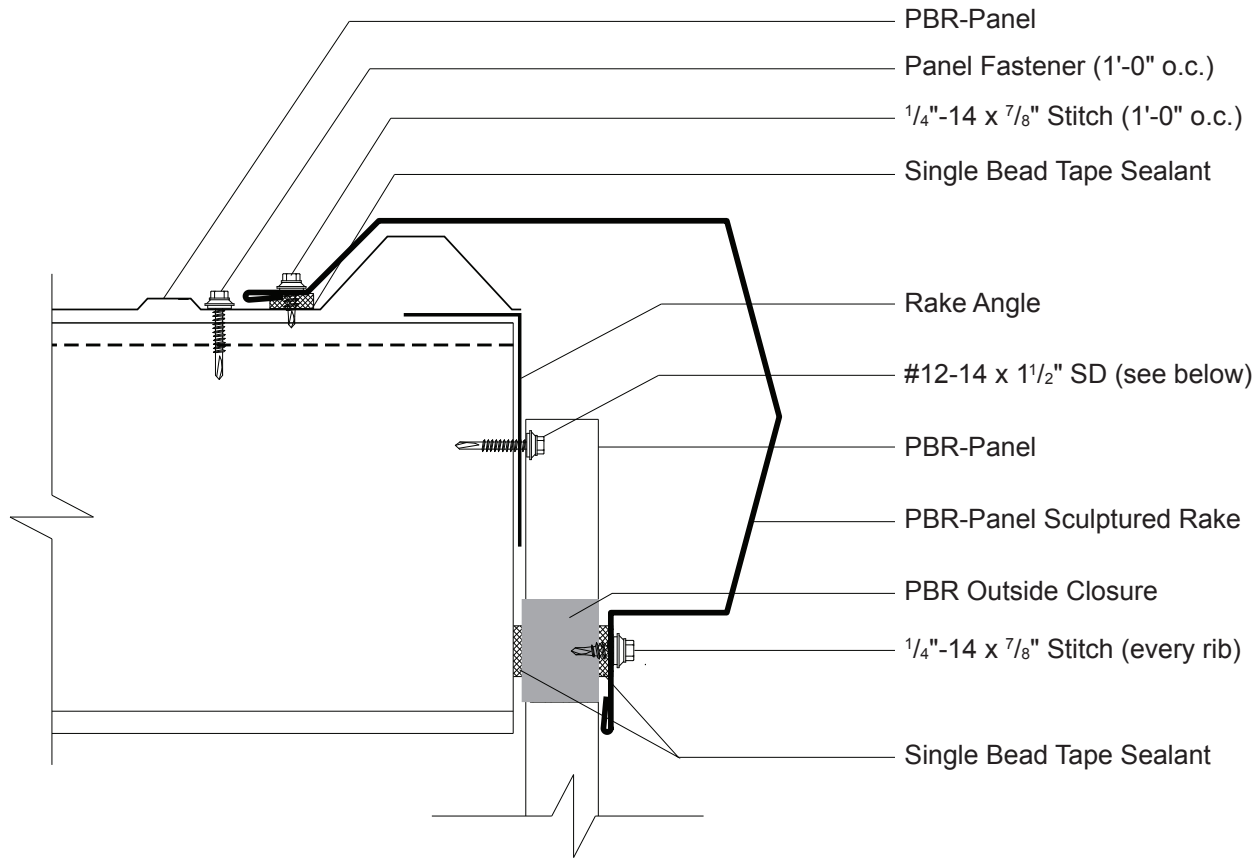

PANEL FASTENER INFORMATION

PBR-PANEL FASTENING PATTERN

Open Framing

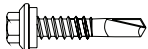

Self Driller
 #12-14 x 1"
 #12-14 x 1-1/2"
 #12-14 x 2"

Solid Wood Substrate

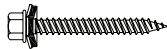

Woodscrew
 #10-14 x 1"
 #10-14 x 1-1/2"
 #10-14 x 2"

2X Wood Framing



Woodscrew
 #10-14 x 1"
 #10-14 x 1-1/2"
 #10-14 x 2"

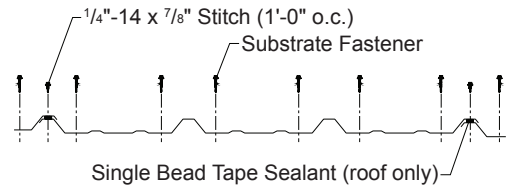

1. Before installing the Sculptured Rake Flashing the Rake Ends will need to be installed.
2. Place the Rake Ends into the end of the Sculptured Rake Flashing and fasten with Pop Rivets.
3. Place the Sculptured Rake Flashing on the rake of the building and lightly mark where the bottom of the flashing hits the wall panel along the slope. Also mark where the edge of the Sculptured Rake rests on the roof panel.
4. Place a row of Single Bead Tape Sealant along the slope of the rake at the top of the wall panel so that it is behind the Sculptured Rake Flashing.
5. Apply a Universal Closure over the Single Bead Tape Sealant. Press firmly into place.
6. For slopes up to three to twelve a PBR Outside Closure can be used for PBR wall panels.
7. The Universal closure will act as a barrier to keep insects and debris from entering the building.
8. Apply a second row of Single Bead Tape Sealant to the face of the Universal Closure. Also apply a row of Single Bead Tape Sealant to the roof panels inside of the marks made.
9. Install the Sculptured Rake Flashing flush against the wall panels, making sure to hide the Universal Closure. Fasten through the closure to the wall panel with a Stitch Fastener at every major rib.
10. Fasten the Sculptured Rake Flashing to the PBR roof panel with a Stitch fastener 1'-0" o.c..

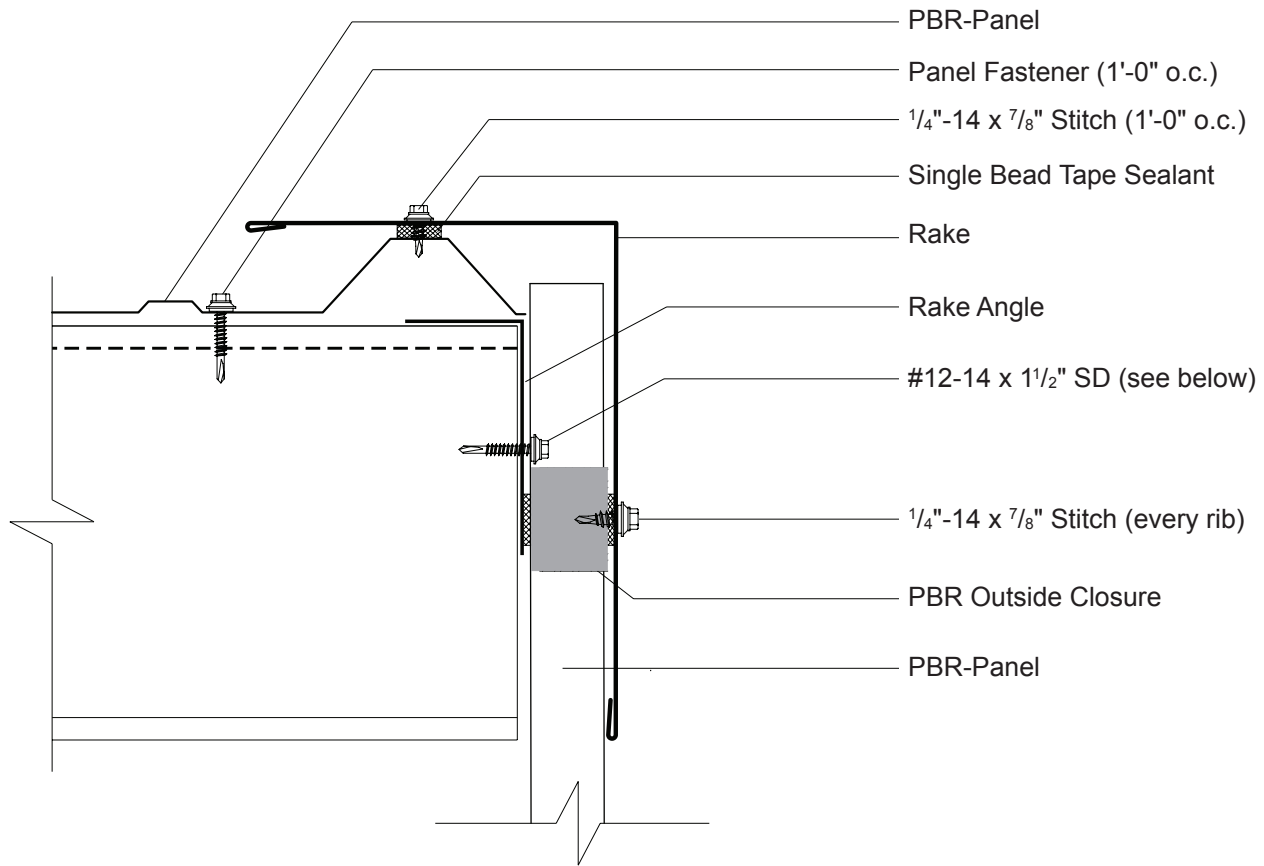

PANEL FASTENER INFORMATION

PBR-PANEL FASTENING PATTERN

Open Framing

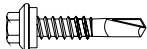

Self Driller
 #12-14 x 1"
 #12-14 x 1-1/2"
 #12-14 x 2"

Solid Wood Substrate

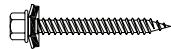

Woodscrew
 #10-14 x 1"
 #10-14 x 1-1/2"
 #10-14 x 2"

2X Wood Framing



Woodscrew
 #10-14 x 1"
 #10-14 x 1-1/2"
 #10-14 x 2"

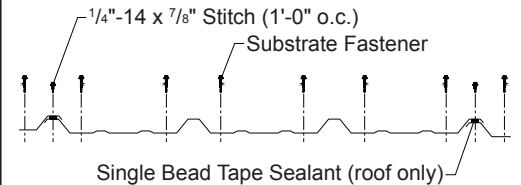

1. Place the Rake Flashing on the rake of the building and lightly mark where the bottom of the flashing hits the wall panel along the slope. Also mark where the edge of the Sculptured Rake rests on the roof panel.
2. Place a row of Single Bead Tape Sealant along the slope of the rake at the top of the wall panel so that it is behind the Sculptured Rake Flashing.
3. Apply a Universal Closure over the Single Bead Tape Sealant. Press firmly into place.
4. For slopes up to three to twelve a PBR Outside Closure can be used for PBR wall panels.
5. The Universal closure will act as a barrier to keep insects and debris from entering the building.
6. Apply a second row of Single Bead Tape Sealant to the face of the Universal Closure. Also apply a row of Single Bead Tape Sealant to the roof panels inside of the marks made.
7. Install the Rake Flashing flush against the wall panels, making sure to hide the Universal Closure. Fasten through the closure to the wall panel with a Stitch Fastener at every major rib.
8. Fasten the Rake Flashing to the PBR roof panel with a Stitch fastener 1'-0" o.c..

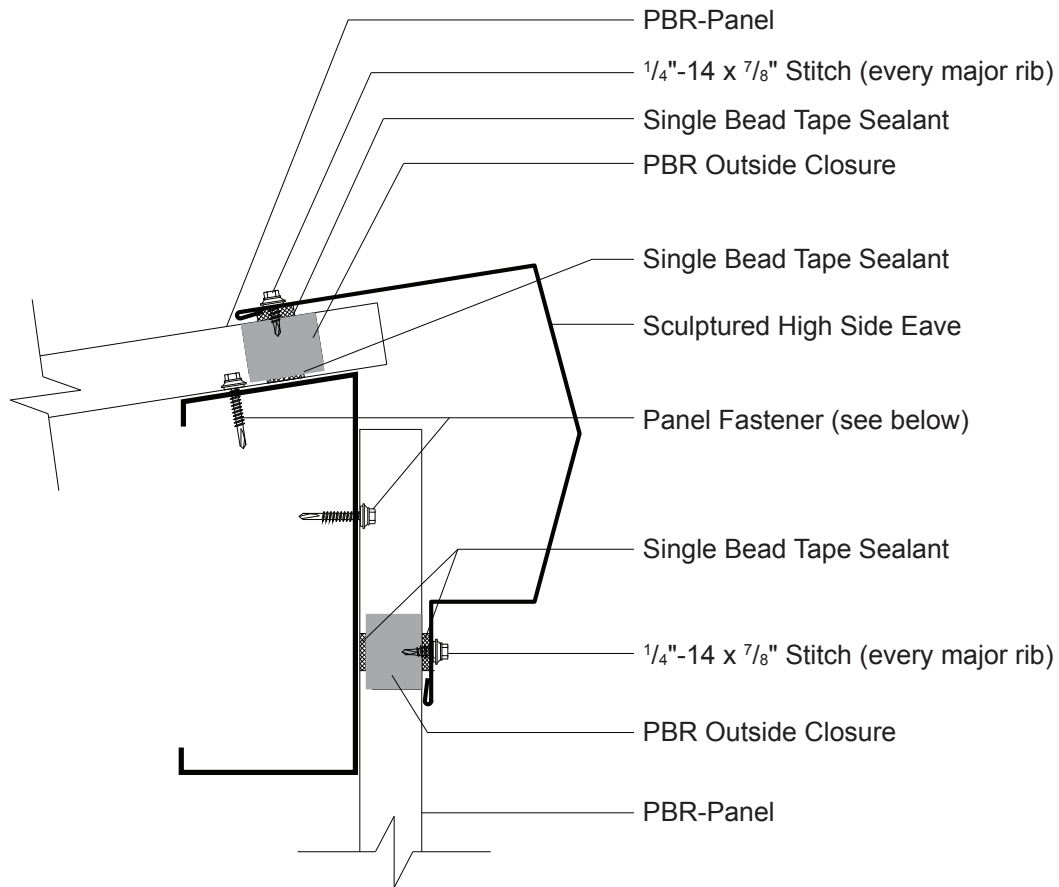

INSTALLATION STEPS

PBR-PANEL FASTENING PATTERN

Open Framing

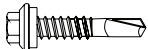

Self Driller
 #12-14 x 1"
 #12-14 x 1-1/2"
 #12-14 x 2"

Solid Wood Substrate

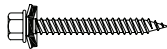

Woodscrew
 #10-14 x 1"
 #10-14 x 1-1/2"
 #10-14 x 2"

2X Wood Framing

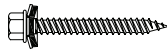

Woodscrew
 #10-14 x 1"
 #10-14 x 1-1/2"
 #10-14 x 2"

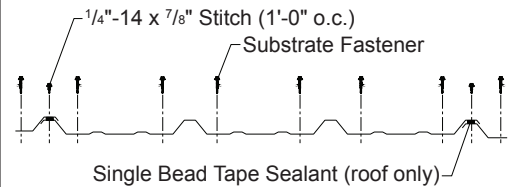

1. Place the Sculptured Highside Eave Flashing at the peak of the roof. Lightly mark where the bottom of the Sculptured Highside Eave Flashing meets the wall panel and the top edge hits the roof panel.
2. Place a row of Single Bead Tape Sealant across the roof panel and over each panel rib above the mark.
3. Place PBR Outside Closures along the length of the highside on the roof panels. Be sure the Outside Closures are located so that the Sculptured Highside Eave Flashing will cover them.
4. Apply a second row of Single Bead Tape Sealant to the top of the outside closures along the highside.
5. Now place a row of Single Bead Tape Sealant along the top of the wall panel so that it is above the wall mark.
6. Place the Outside Closures or a Universal Closure over the Single Bead Tape Sealant. The Outside Closure or Universal Closure will act as a barrier to keep insects and debris from entering the building.
7. Apply a second row of Single Bead Tape Sealant to the top of the Outside Closures along the at the wall.
8. Place Sculptured Highside Eave Flashing flush against the roof and wall panels.
9. Fasten the Sculptured Highside Eave Flashing to the PBR roof panel through the PBR Outside Closures with Stitch Fasteners, one at every major rib.
10. Now fasten the Sculptured Highside Eave Flashing to the wall with Stitch Fasteners at every major rib.

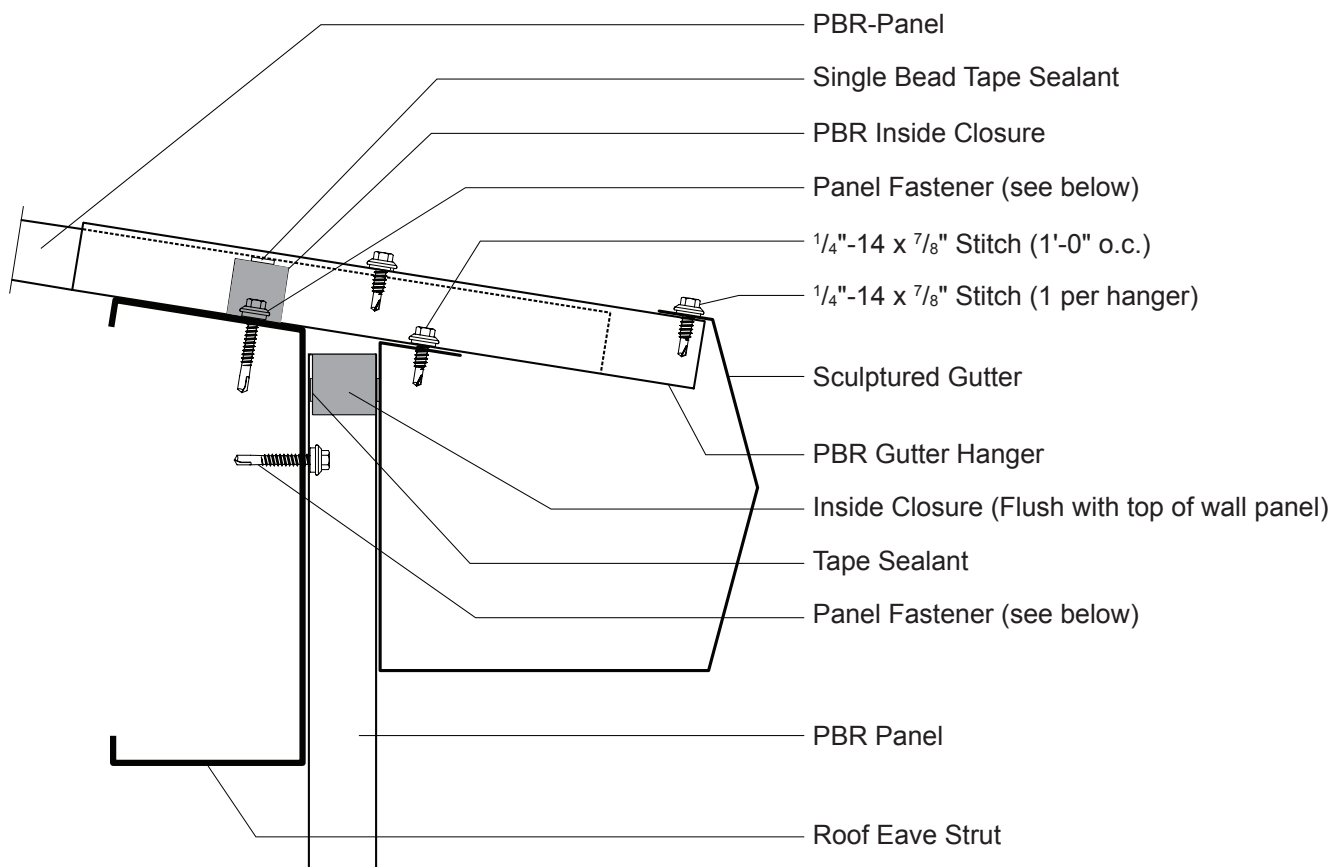

PANEL FASTENER INFORMATION

Open Framing

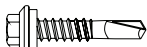

Self Driller
 #12-14 x 1"
 #12-14 x 1-1/2"
 #12-14 x 2"

Solid Wood Substrate



Woodscrew
 #10-14 x 1"
 #10-14 x 1-1/2"
 #10-14 x 2"

2X Wood Framing



Woodscrew
 #10-14 x 1"
 #10-14 x 1-1/2"
 #10-14 x 2"

PBR-PANEL FASTENING PATTERN

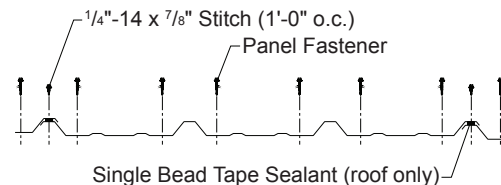

INSTALLATION STEPS

1. Install the Gutter Hangers. They need to be spaced at no greater than three feet on center along the gutter line.
2. Hold the Sculptured Gutter in place flush against the Eave Flashing. Set the Gutter Hanger on top of the major rib of the PBR roof panel and slide the Gutter Hanger into the front of the gutter. Lightly mark on the panel the end of the gutter hanger. Measure and install the other Gutter Hangers down the length of the Gutter.
3. Apply Single Bead Tape Sealant to the top of the ribs. Place the Gutter Hangers as marked and fasten the Gutter Hanger to the major rib of the panel with two Stitch Fasteners.
4. Once all of the Gutter Hangers are in place install the Sculptured Gutter flashing back against the Eave Flashing.
5. Fasten the back of the Sculptured Gutter flashing to the end of the roof panel with Stitch Fasteners at a maximum of 1'-0" on center.
6. Now fasten the front of the Sculptured Gutter to the Gutter Hangers with Stitch Fasteners. One fastener per Gutter Hanger.
7. And as always *remember* the size and gauge of the Sculptured Gutter should be designed to applicable governing building codes.

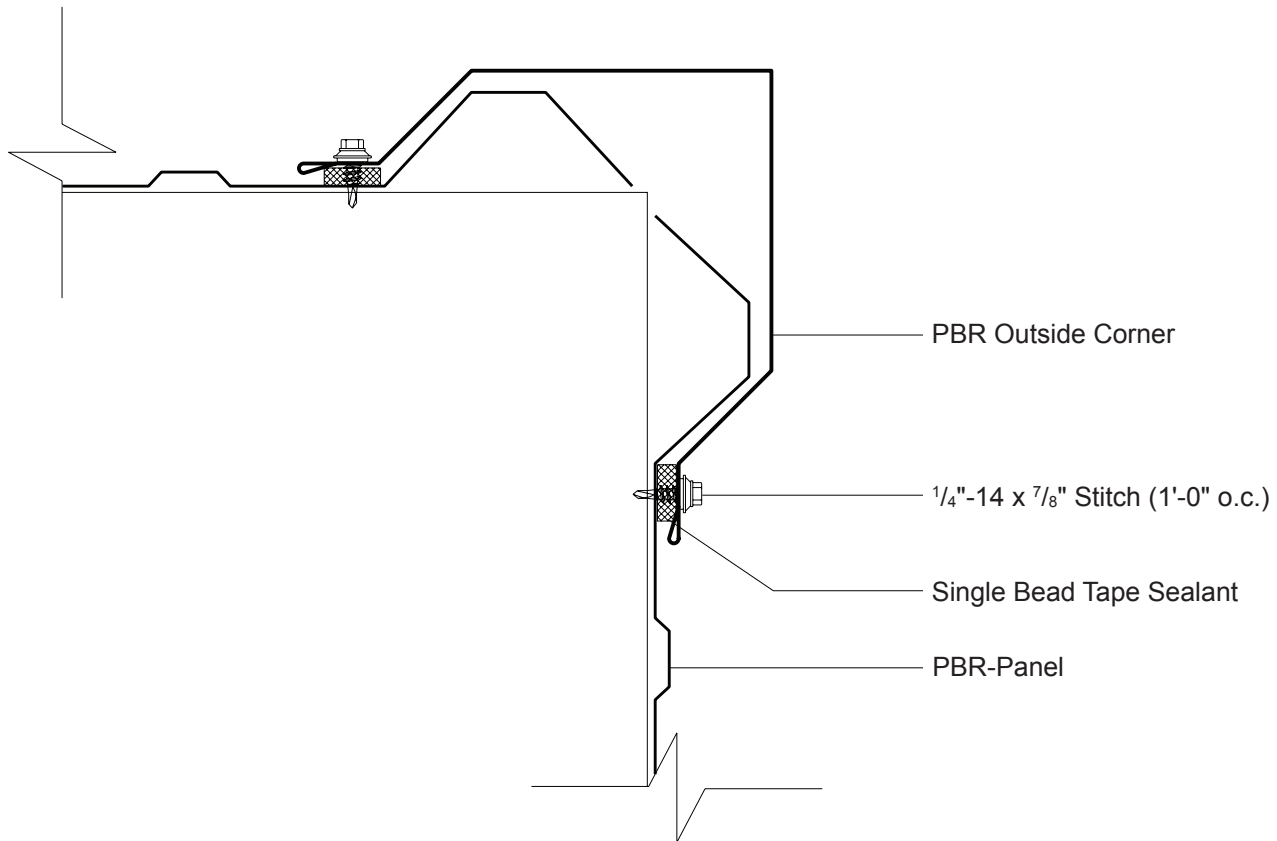

PANEL FASTENER INFORMATION

OPTIONAL FLASHING

Open Framing

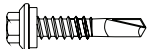

Self Driller
 #12-14 x 1"
 #12-14 x 1-1/2"
 #12-14 x 2"

Solid Wood Substrate

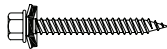

Woodscrew
 #10-14 x 1"
 #10-14 x 1-1/2"
 #10-14 x 2"

2X Wood Framing



Woodscrew
 #10-14 x 1"
 #10-14 x 1-1/2"
 #10-14 x 2"

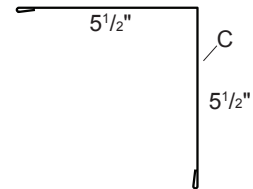

Note: Outside Corner Flashings should be installed working from the ground up.

1. After the PBR wall panel is installed place the first Outside Corner Flashing at the base of the building.
2. Install a row of Single Bead Tape Sealant on each side of the Outside Corner Flashing.
3. Place the Outside Corner Flashing on the wall panels.
4. Fasten to the wall panels with 1/4"-14 x 7/8" Stitch Fasteners, 1'-0" on center.
5. If more than one Outside Corner Flashing is needed then a flashing lap is required.
6. Apply two rows of Tube Sealant to the top of the installed Outside Corner Flashing.
7. Lap the flashings a minimum of 3" and fasten with Pop Rivets 2" on center.

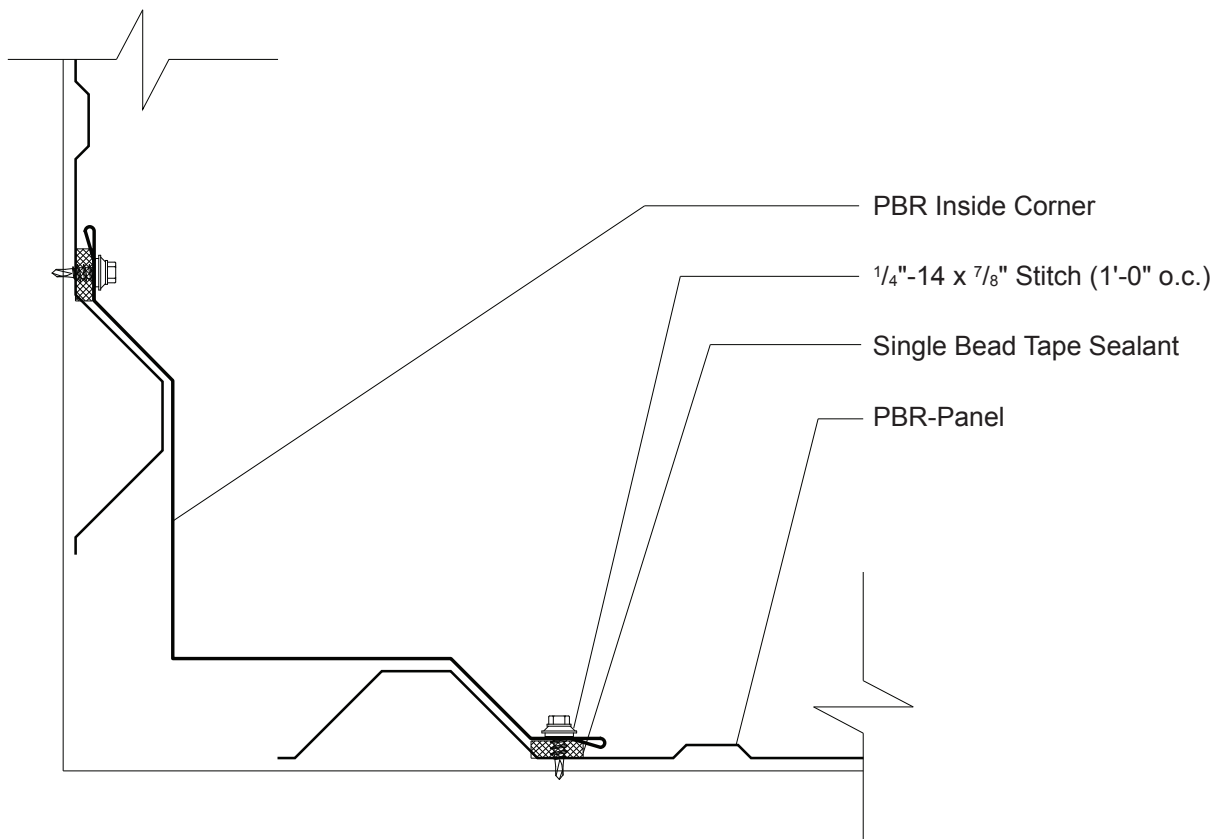

PANEL FASTENER INFORMATION

OPTIONAL FLASHING

Open Framing

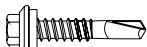

Self Driller
 #12-14 x 1"
 #12-14 x 1-1/2"
 #12-14 x 2"

Solid Wood Substrate



Woodscrew
 #10-14 x 1"
 #10-14 x 1-1/2"
 #10-14 x 2"

2X Wood Framing



Woodscrew
 #10-14 x 1"
 #10-14 x 1-1/2"
 #10-14 x 2"

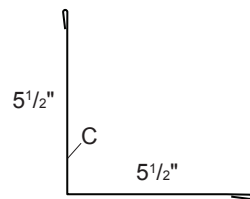

Note: Inside Corner Flashings should be installed working from the ground up.

1. After the PBR wall panel is installed place the first Inside Corner Flashing at the base of the building.
2. Install a row of Single Bead Tape Sealant on each side of the Inside Corner Flashing.
3. Place the Inside Corner Flashing on the wall panels.
4. Fasten to the wall panels with 1/4"-14 x 7/8" Stitch Fasteners, 1'-0" on center.
5. If more than one Inside Corner Flashing is needed then a flashing lap is required.
6. Apply two rows of Tube Sealant to the top of the installed Inside Corner Flashing.
7. Lap the flashings a minimum of 3" and fasten with Pop Rivets 2" on center.

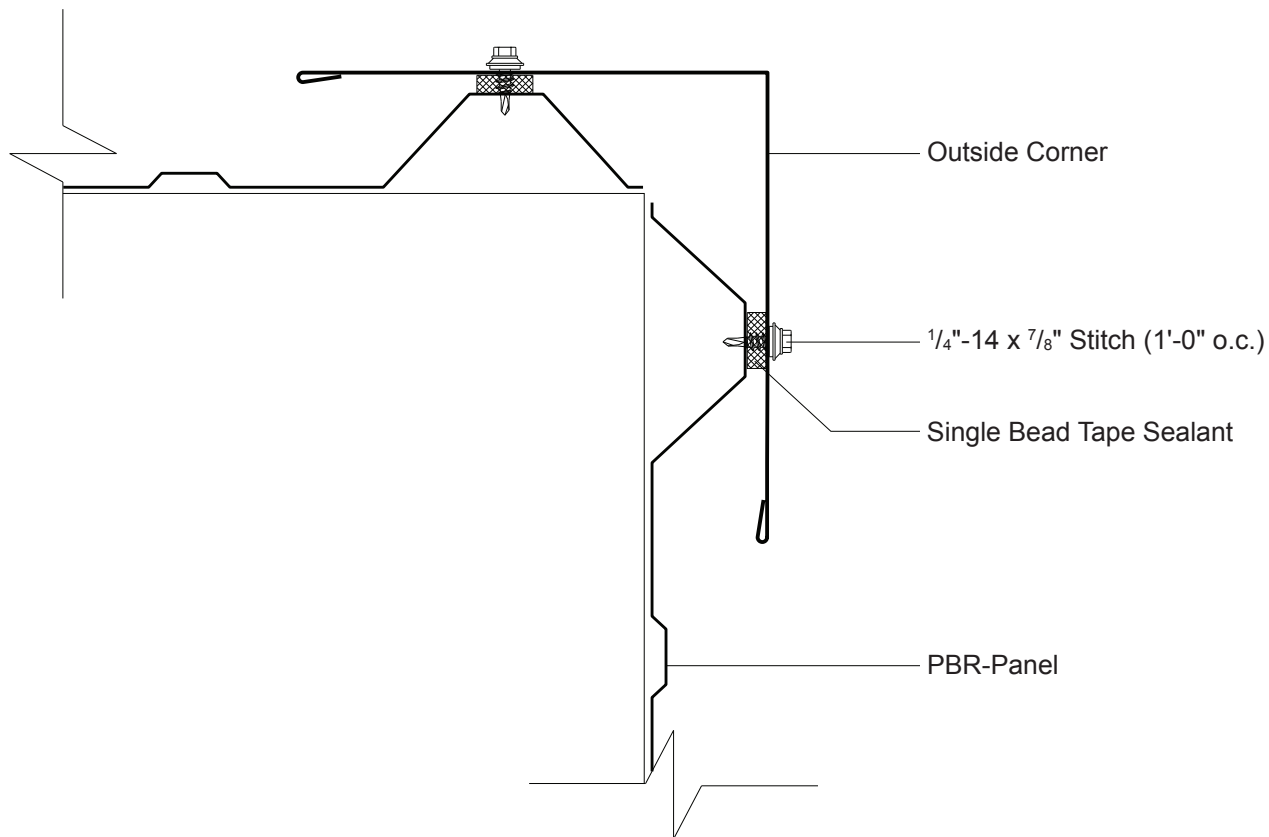

REVERSE-ROLL WALL PANEL

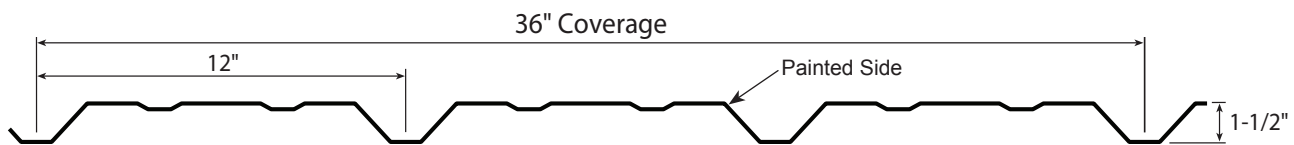

Note: Outside Corner Flashings should be installed working from the ground up.

1. After the PBR wall panel is installed place the first Outside Corner Flashing at the base of the building.
2. Install a row of Single Bead Tape Sealant on each side of the Outside Corner Flashing.
3. Place the Outside Corner Flashing on the wall panels.
4. Fasten to the wall panels with 1/4"-14 x 7/8" Stitch Fasteners, 1'-0" on center.
5. If more than one Outside Corner Flashing is needed then a flashing lap is required.
6. Apply two rows of Tube Sealant to the top of the installed Outside Corner Flashing.
7. Lap the flashings a minimum of 3" and fasten with Pop Rivets 2" on center.

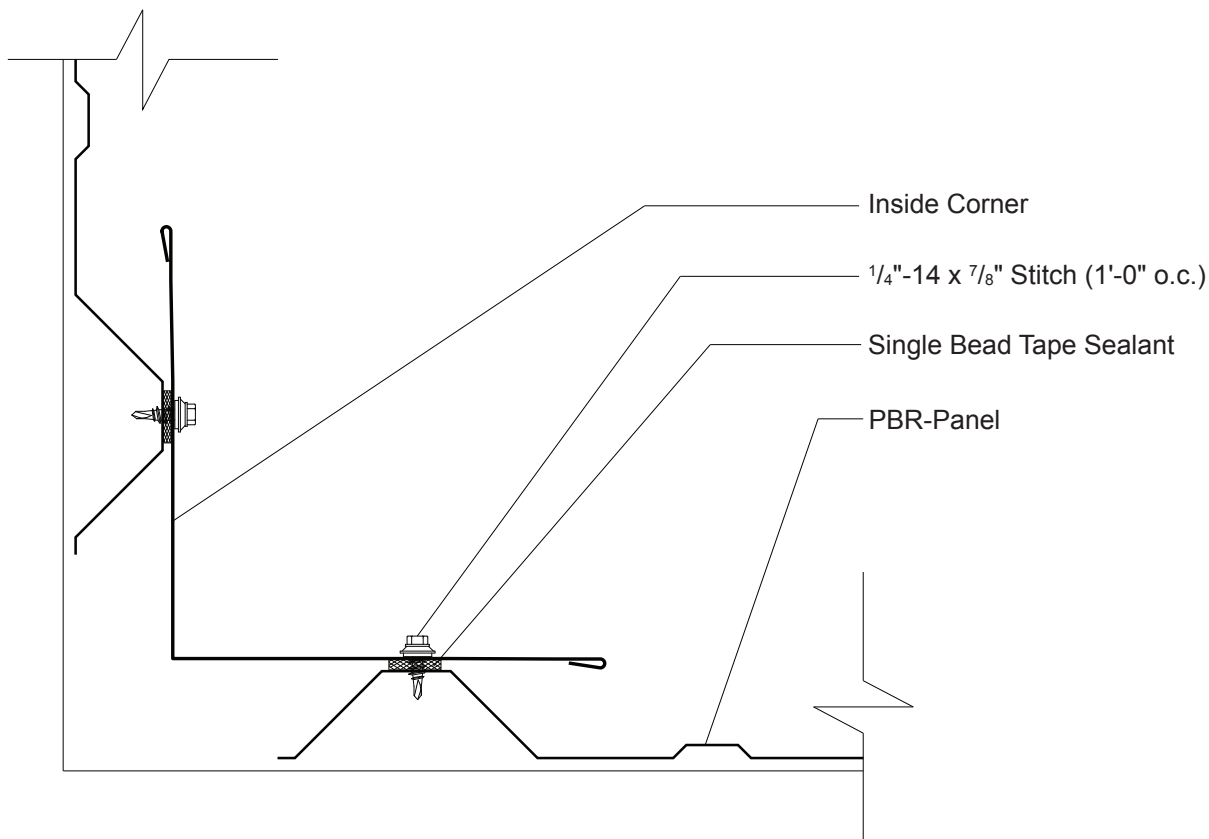

REVERSE-ROLL WALL PANEL

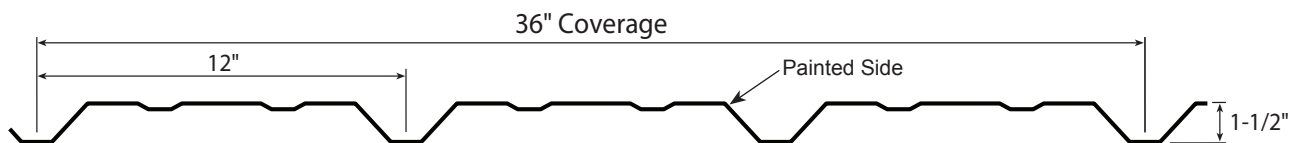

Note: Inside Corner Flashings should be installed working from the ground up.

1. After the PBR wall panel is installed place the first Inside Corner Flashing at the base of the building.
2. Install a row of Single Bead Tape Sealant on each side of the Inside Corner Flashing.
3. Place the Inside Corner Flashing on the wall panels.
4. Fasten to the wall panels with 1/4"-14 x 7/8" Stitch Fasteners, 1'-0" on center.
5. If more than one Inside Corner Flashing is needed then a flashing lap is required.
6. Apply two rows of Tube Sealant to the top of the installed Inside Corner Flashing.
7. Lap the flashings a minimum of 3" and fasten with Pop Rivets 2" on center.

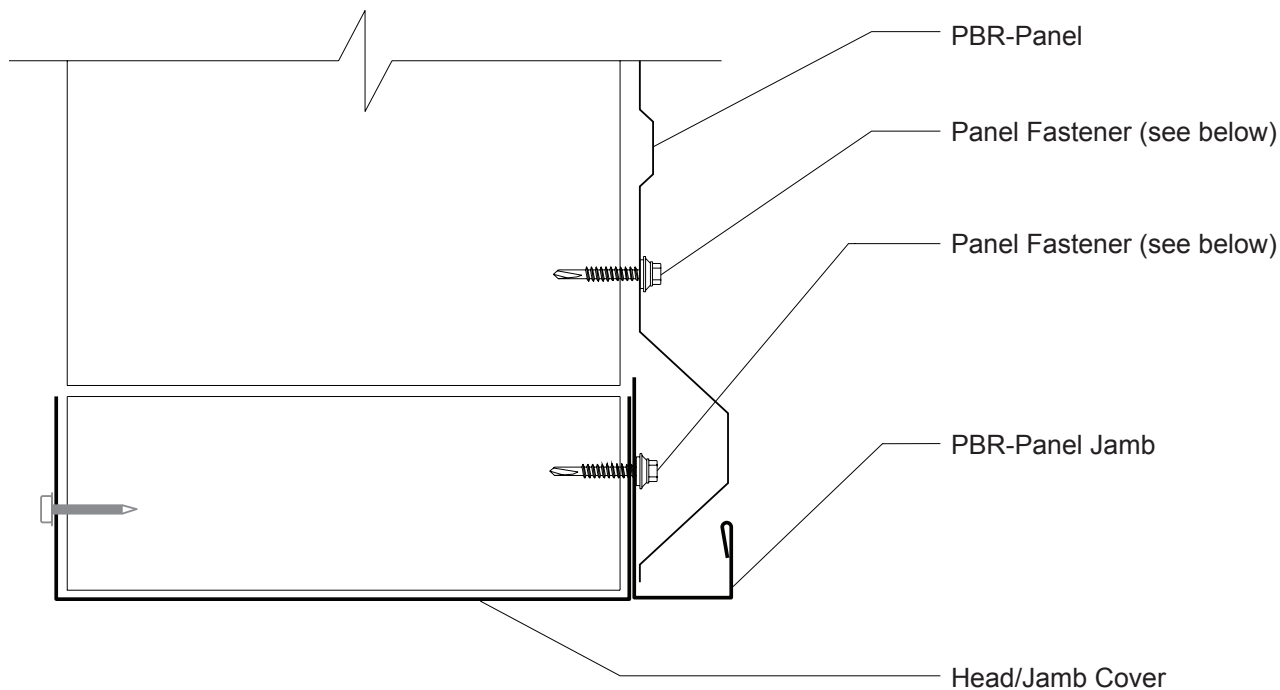

PANEL FASTENER INFORMATION

PBR-PANEL FASTENING PATTERN

Open Framing

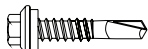

Self Driller
 #12-14 x 1"
 #12-14 x 1-1/2"
 #12-14 x 2"

Solid Wood Substrate



Woodscrew
 #10-14 x 1"
 #10-14 x 1-1/2"
 #10-14 x 2"

2X Wood Framing



Woodscrew
 #10-14 x 1"
 #10-14 x 1-1/2"
 #10-14 x 2"

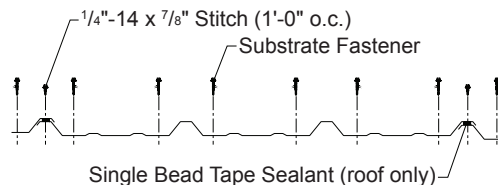

Single Bead Tape Sealant (roof only)

Note: Install the relevant framing such as girts and opening framing.

1. Put Head / Jamb Cover in place and fasten on the inside with Panel Fastener spaced 1'-0" on center.
2. Hold the Head / Jamb Cover and PBR-Panel Jamb in place and fasten with Panel Fastener spaced 1'-0" on center.
3. Install PBR-Panels with the Panel Fastener using the patterns shown on page 31.
4. Lap the PBR-Panel Jamb flashing 2" and apply tube sealant between the trims and fasten with two Pop Rivets, one in each exposed segment. Lap the Head / Jamb Cover trim 2" and apply tube sealant between the trims.

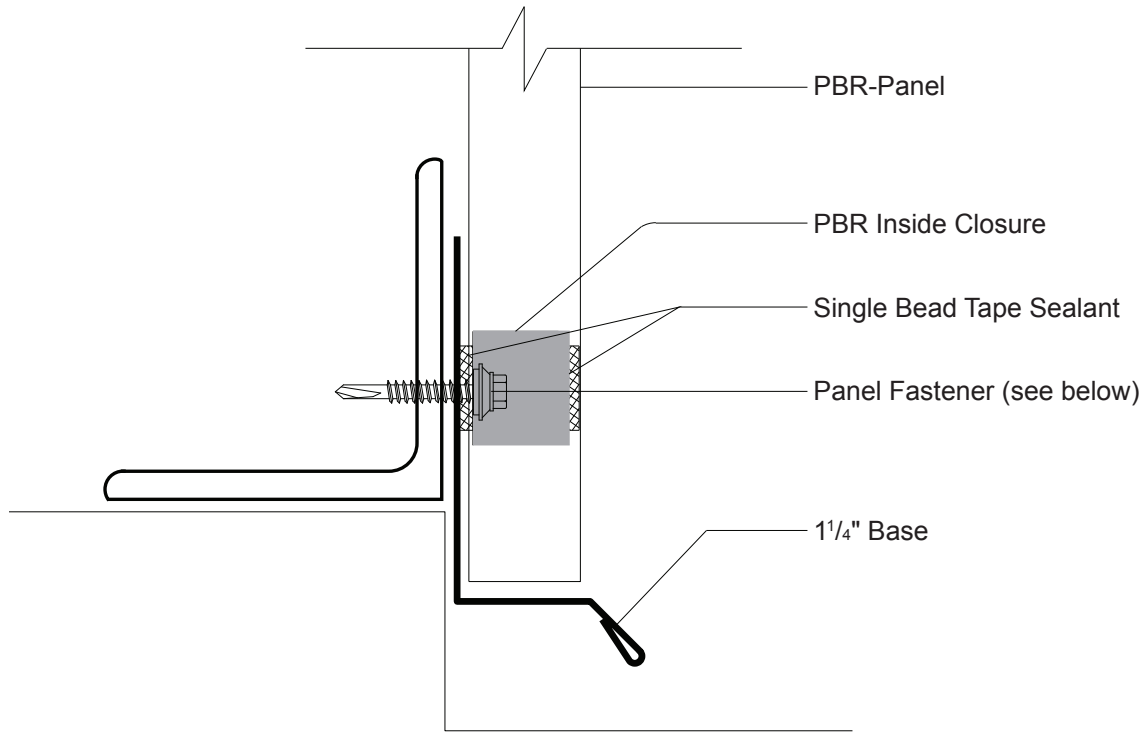

PANEL FASTENER INFORMATION

PBR-PANEL FASTENING PATTERN

Open Framing

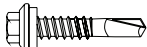

Self Driller
 #12-14 x 1"
 #12-14 x 1-1/2"
 #12-14 x 2"

Solid Wood Substrate



Woodscrew
 #10-14 x 1"
 #10-14 x 1-1/2"
 #10-14 x 2"

2X Wood Framing



Woodscrew
 #10-14 x 1"
 #10-14 x 1-1/2"
 #10-14 x 2"

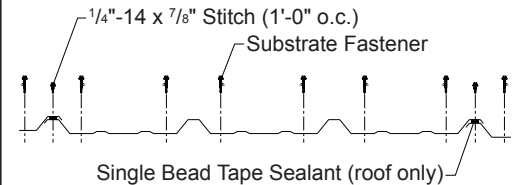

Note: Install the relevant framing such as girts and Base Angle.

1. Tack the 1 1/4" Base trim in place with Pancake Head fastener (not shown) spaced 4' on center and located at a major rib and near the top of the trim.
2. Make sure the horizontal segment of 1 1/4" Base has a slight slope so it will not hold water. The horizontal segment should be located approximately 1" below the slab elevation. Allow 1/4" gap from the end of the panel.
3. Place a bead of Single Bead Tape Sealant to the vertical segment of the 1 1/4" Base where the Panel Fasteners will be located. Next apply the PBR-Panel Inside Closure on the bead of Single Bead Tape Sealant. Press the Inside closure firmly in place.
4. Place a bead of Single Bead Tape Sealant on the PBR-Panel Inside Closure.
5. Locate PBR-Panel wall panel in place with 1/4" gap between the end of the panel and the horizontal segment of the 1 1/4" Base trim and fasten with Panel Fasteners using the fastening patterns shown on page 31.
6. Lap the 1 1/4" Base trim 2" and apply tube sealant between the trims and fasten with two Pop Rivets, one in each exposed segment.

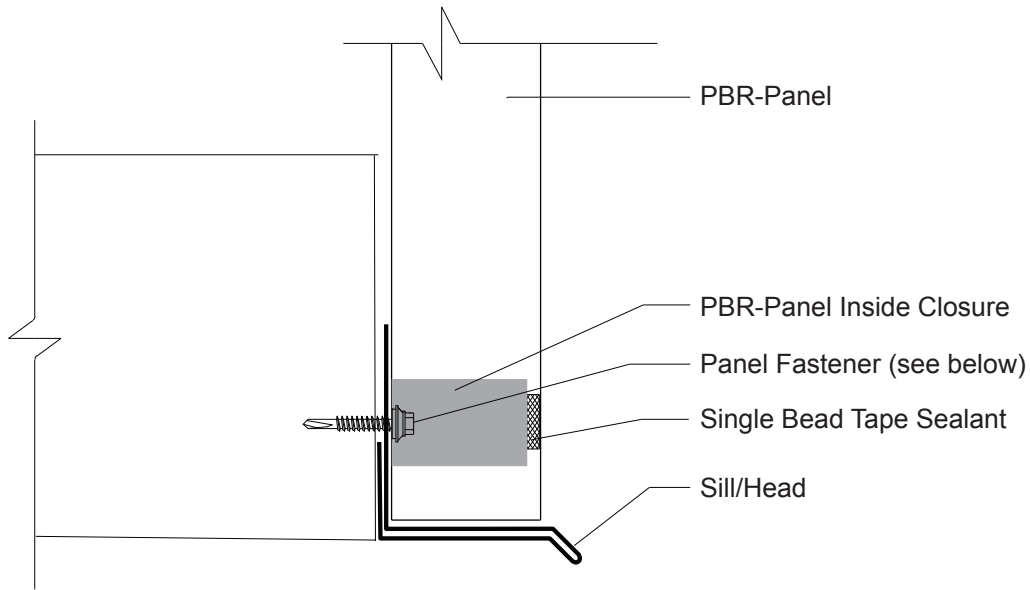

PANEL FASTENER INFORMATION

PBR-PANEL FASTENING PATTERN

Open Framing

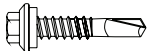

Self Driller
 #12-14 x 1"
 #12-14 x 1-1/2"
 #12-14 x 2"

Solid Wood Substrate

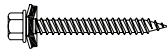

Woodscrew
 #10-14 x 1"
 #10-14 x 1-1/2"
 #10-14 x 2"

2X Wood Framing



Woodscrew
 #10-14 x 1"
 #10-14 x 1-1/2"
 #10-14 x 2"

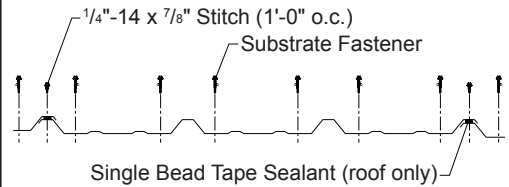

Note: Install the relevant wall framing such as girts.

1. Tack the Sill / Head trim in place with Pancake Head fastener (not shown) spaced 4' on center and located at a major rib and near the top of the trim.
2. Make sure the horizontal segment of Sill/Head trim has a slight slope so it will not hold water. The horizontal segment should be aligned with the top of the opening. Allow 1/4" gap from the end of the panel.
3. Place a bead of Single Bead Tape Sealant to the vertical segment of the Sill / Head trim where the Panel Fasteners will be located. Next apply the PBR-Panel Inside Closure on the bead of Single Bead Tape Sealant. Press the Inside closure firmly in place.
4. Place a bead of Single Bead Tape Sealant on the PBR-Panel Inside Closure.
5. Locate PBR-Panel wall panel in place with 1/4" gap between the end of the panel and the horizontal segment of the Sill/Head trim and fasten with Panel Fasteners using the fastening patterns shown on page 31.
6. Lap the Sill/Head trim 2" and apply tube sealant between the trims and fasten with one Pop Rivet in the horizontal segment, from the bottom.

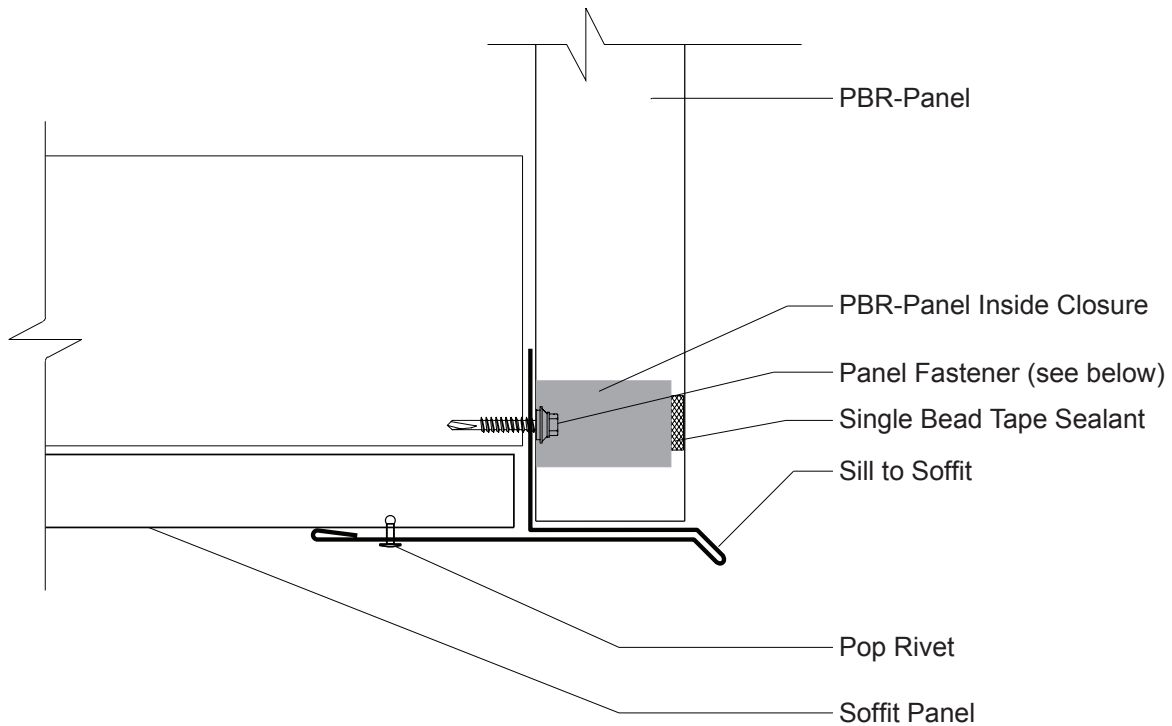

PANEL FASTENER INFORMATION

Open Framing



Self Driller
 #12-14 x 1"
 #12-14 x 1-1/2"
 #12-14 x 2"

Solid Wood Substrate



Woodscrew
 #10-14 x 1"
 #10-14 x 1-1/2"
 #10-14 x 2"

2X Wood Framing



Woodscrew
 #10-14 x 1"
 #10-14 x 1-1/2"
 #10-14 x 2"

PBR-PANEL FASTENING PATTERN

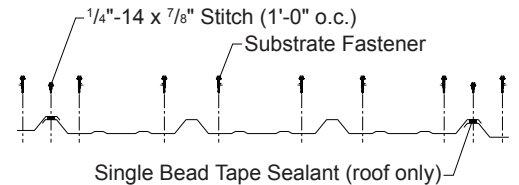

Note: Install the relevant wall framing such as girts and install the Soffit panel.

1. Tack the Sill to Soffit trim in place with Panel Fastener (not shown) spaced 4' on center and located at a major rib of the wall panel and near the top of the trim.
2. Make sure the horizontal segment of Sill to Soffit trim has a slight slope so it will not hold water. The horizontal segment should be aligned with the face of the Soffit Panel. Allow 1/4" gap from the end of the panel.
3. Fasten Sill to Soffit trim to the Soffit Panel with Pop Rivets spaced 1'-0" on center.
4. Place a bead of Single Bead Tape Sealant to the vertical segment of the Sill to Soffit trim where the Panel Fasteners will be located. Next apply the PBR-Panel Inside Closure on the bead of Single Bead Tape Sealant. Press the Inside closure firmly in place.
5. Place a bead of Single Bead Tape Sealant on the PBR-Panel Inside Closure.
6. Locate PBR-Panel wall panel in place with 1/4" gap between the end of the panel and the horizontal segment of the Sill to Soffit trim and fasten with Panel Fasteners using the fastening patterns shown on page 29.
7. Lap the Sill to Soffit trim 2" and apply tube sealant between the trims and fasten with two Pop Rivets in the horizontal segment, from the bottom.

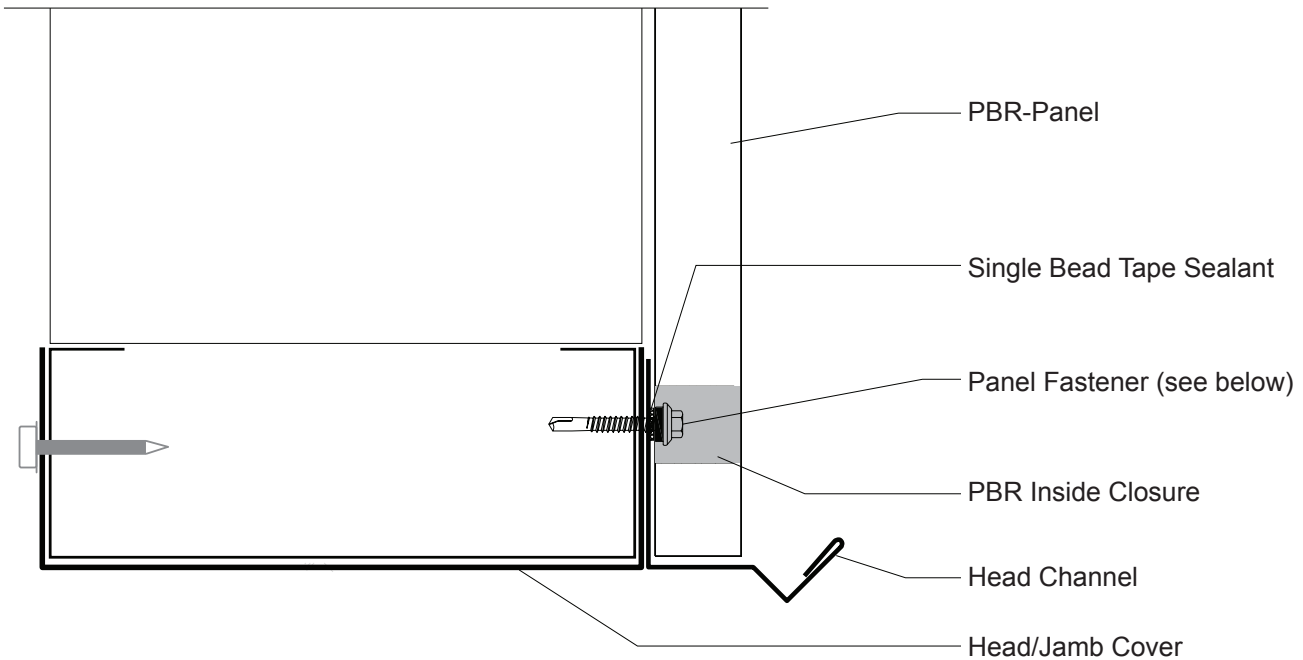

PANEL FASTENER INFORMATION

PBR-PANEL FASTENING PATTERN

Open Framing

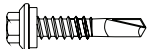

Self Driller
 #12-14 x 1"
 #12-14 x 1-1/2"
 #12-14 x 2"

Solid Wood Substrate



Woodscrew
 #10-14 x 1"
 #10-14 x 1-1/2"
 #10-14 x 2"

2X Wood Framing



Woodscrew
 #10-14 x 1"
 #10-14 x 1-1/2"
 #10-14 x 2"

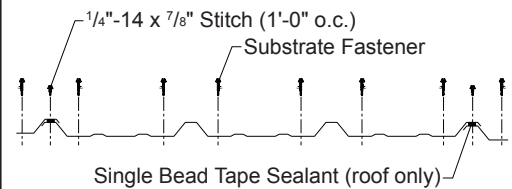

Note: Install the relevant wall framing such as girts.

1. Put Head / Jamb Cover in place and fasten on the inside with Panel Fastener spaced 1'-0" on center.
2. Hold the Head / Jamb Cover and Head Channel in place and tack with Panel Fastener (not shown) spaced 4' on center and located at a major rib of the wall panel near the top of the trim. The Head Channel trim can be installed with a slight slope to promote water in the V-Channel to run off along the length of the trim.
3. Make sure the horizontal segment of the Head Channel trim has a slight slope so it will not hold water. The horizontal segment should be aligned with the top of the opening. Allow 1/4" gap from the end of the panel.
4. Place a bead of Single Bead Tape Sealant to the vertical segment of the Head Channel trim where the Panel Fasteners will be located. Next apply the PBR-Panel Inside Closure on the bead of Single Bead Tape Sealant. Press the Inside closure firmly in place.
5. Place a bead of Single Bead Tape Sealant on the PBR-Panel Inside Closure.
6. Locate PBR-Panel wall panel in place with 1/4" gap between the end of the panel and the horizontal segment of the Head Channel trim and fasten with Panel Fasteners using the fastening patterns shown on page 29 through the Single Bead Tape Sealant and PBR-Panel Inside Closure.
7. If possible, use single-piece Head Channel trims. If necessary, lap the Head Channel trim 2" and apply tube sealant between the trims and fasten with three Pop Rivets, one in each of the exposed segments, from the bottom. Lap the Head / Jamb Cover trim 2" and apply tube sealant between the trims.

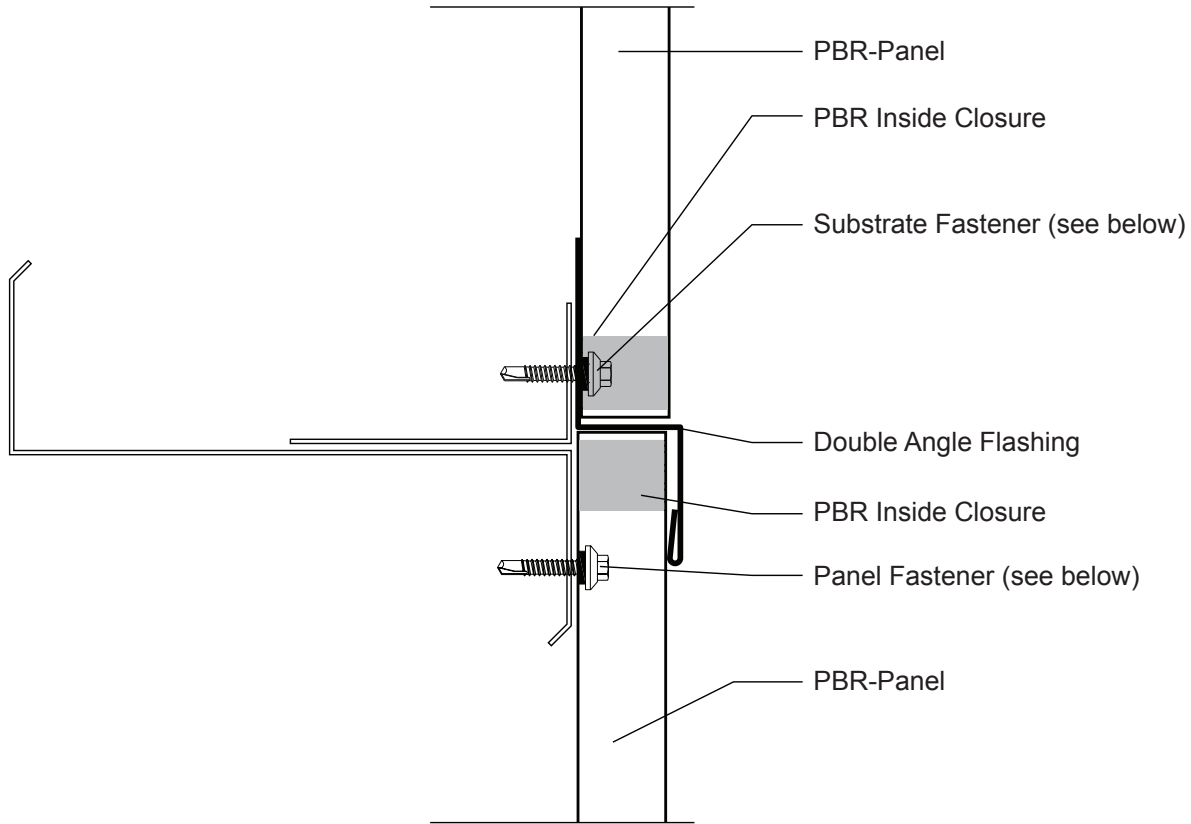

PANEL FASTENER INFORMATION

PBR-PANEL FASTENING PATTERN

Open Framing

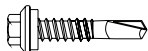

Self Driller
 #12-14 x 1"
 #12-14 x 1-1/2"
 #12-14 x 2"

Solid Wood Substrate



Woodscrew
 #10-14 x 1"
 #10-14 x 1-1/2"
 #10-14 x 2"

2X Wood Framing



Woodscrew
 #10-14 x 1"
 #10-14 x 1-1/2"
 #10-14 x 2"

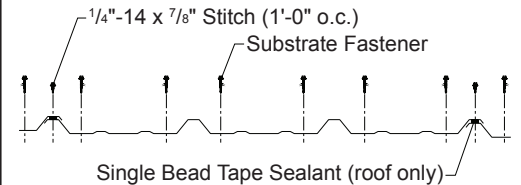

Note: Install the relevant wall framing such as girts and support angle as shown.

1. Place a bead of Single Bead Tape Sealant to the girt near the top of the lower panel location. Next apply the PBR-Panel Inside Closure on the bead of Single Bead Tape Sealant. Press the Inside closure firmly in place. Place a bead of Single Bead Tape Sealant on the PBR-Panel Inside Closure.
2. Install the lower panel with the top aligned with the top of the PBR-Panel Inside Closure. Fasten the panel in place with Panel Fasteners, using the fastening patterns shown on page 31 through the Single Bead Tape Sealant and PBR-Panel Inside Closure.
3. Tack the Double Angle Flashing in place with Panel Fastener (not shown) spaced 4' on center and located at a major rib of the wall panel and near the top of the trim.
4. Place a bead of Single Bead Tape Sealant to the Double Angle Flashing near the bottom of the upper panel location. Next apply the PBR-Panel Inside Closure on the bead of Single Bead Tape Sealant. Press the Inside closure firmly in place. Place a bead of Single Bead Tape Sealant on the PBR-Panel Inside Closure.
5. Install the upper panel with the bottom 1/4" above the horizontal segment of the Double Angle Flashing. Fasten the panel in place with Panel Fasteners, using the fastening patterns shown on page 31 through the Single Bead Tape Sealant and PBR-Panel Inside Closure.
6. Lap the Double Angle Flashing 2" and apply tube sealant between the trims and fasten with one Pop Rivet in the outer vertical segment of the flashing.